



# Piping Stress and Flexibility Analysis Software

## dPIPE 5

### User Manual

Version 5.2.9

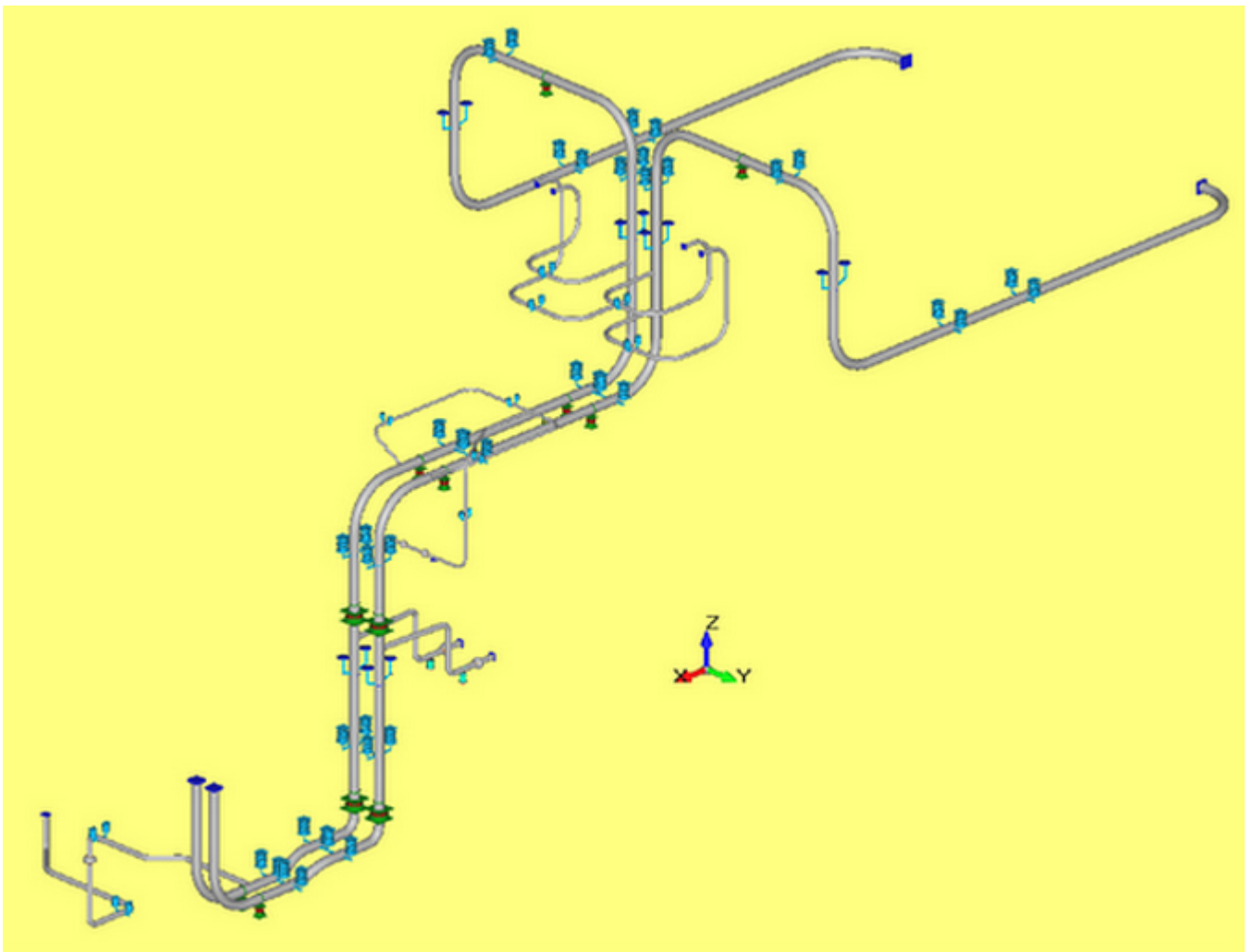

# Table of Contents

<b>Part I</b>	<b>Abbreviations</b>	<b>6</b>
<b>Part II</b>	<b>Introduction</b>	<b>6</b>
<b>Part III</b>	<b>Software structure. File system</b>	<b>7</b>
<b>Part IV</b>	<b>PC configuration requirements</b>	<b>10</b>
<b>Part V</b>	<b>Software installation</b>	<b>10</b>
<b>Part VI</b>	<b>Protection keys and License Management</b>	<b>11</b>
1	User hardware Key Sentinel HL Pro DL.....	11
2	Network Hardware Key HL-NET.....	12
3	User Software Key SL-UserMode.....	12
4	Network Software Key SL-AdminMode.....	13
5	dPIPE in Sub-Network.....	14
6	Sentinel SL License Transfer between two PCs.....	15
<b>Part VII</b>	<b>DDE spreadsheet</b>	<b>17</b>
1	Spreadsheet interface.....	17
2	Spreadsheet navigation.....	23
3	Partial visualization of the model.....	25
4	Copy, paste, modify and delete piping segments.....	29
5	Changing the number display format.....	32
6	Toolbars.....	32
	Main toolbar.....	34
	"Piping" toolbar.....	35
	Spreadsheets with basic data.....	35
	Analysis.....	36
	Additional data.....	36
	Operations with the graphic window.....	37
	Graphic input of the model.....	38
7	Hot key summary.....	39
8	Menu commands.....	41
	File.....	41
	Create PCF.....	42
	Archive Project.....	43
	dP5 Backup.....	44
	Edit.....	44
	View.....	44
	Tools.....	45
	Group operations with supports.....	47
	External programs.....	49
	Interface Language.....	51
	Options and settings.....	51

Files .....	52
Reports .....	53
Templates .....	54
Supports & Spring Hangers.....	54
Output Listing.....	55
Valves .....	56
Small Bore Pipes.....	57
Control parameters.....	58
Main parameters.....	58
Dynamic parameters.....	60
Code .....	61
Hangers and Supports .....	63
Specifications.....	64
Fatigue Analysis.....	64
HELB .....	66
Export to LICAD.....	67
Display options.....	68
<b>Analysis .....</b>	<b>69</b>
<b>Utilities .....</b>	<b>71</b>
<b>Main Data .....</b>	<b>72</b>
<b>Additional data .....</b>	<b>79</b>
<b>Help .....</b>	<b>81</b>

**Part VIII Input data language 82**

<b>1 General commands.....</b>	<b>84</b>
Insert data from another file (INCLUDE) .....	85
Model title (TITLE) .....	85
Control parameters (CTRL) .....	86
Fatigue Data (FAT) .....	100
Creep Data (CREEP) .....	101
Materials (MAT) .....	103
Pipe cross-section (PIPE) .....	108
Standard Bends (&BEND).....	110
Standard Miter Bends (&MITR).....	111
Standard Tee Connections (&TEE).....	113
Beam cross-section (BEAM) .....	115
Operating modes (OPVAL) .....	118
Discont. stresses due to temp. gradient and stratification (GRAD) .....	120
Water oxidation (ENVFAT) .....	122
Data for spring hangers and supports (SDEF) .....	123
Seismic response spectra (SPEC) .....	124
Seismic accelerograms (ACCE) .....	126
Specification for analysis (SOLV) .....	128
Specification for Dynamic Analyses (DCASE) .....	132
Specification for postprocessor (POST) .....	137
Specification for fatigue analysis (FATG) .....	142
Specification for HELB analysis (POST_HELB) .....	145
Specification for report generation (POST_REP) .....	147
Specification for Support's Allowable Loads (SUP_LOADS) .....	152
Export of piping Supports Loads to LICAD (DP2LCD) .....	153
Managing the databases (DBF) .....	155
Suppressing results by headers (\$NOHEAD) .....	157
Stress calculation Saf without allowable stress data (\$SAF_ALLW) .....	157
End of input data (END_OF_DATA) .....	157
<b>2 Local Commands.....</b>	<b>157</b>
Initialization parameters .....	162
From (F) .....	163

Straight pipe (P) .....	164
Bend-1 (B) .....	165
Bend-2 (B) .....	168
Miter bend (MTR) .....	169
Reducer (R) .....	172
Valve (V) .....	175
"Half-valve" (V1, V2 commands) .....	179
Angle valve (VA) .....	181
Valve with offset (VO) .....	187
3-way valve (V3W) .....	193
Expansion Joint (EJ) .....	198
Axial Expansion Joint (EA) .....	202
Tied Expansion Joint (ET) .....	205
Hinge Expansion Joint (EH) .....	207
Gimbal Expansion Joint (EG) .....	209
Rigid Link (RX/RP) .....	211
Flexible Joint (FJ) .....	213
Cold Spring (CS) .....	215
Beam (S) .....	216
Set Position (POS) .....	218
Tee/Branch Connection (TEE) .....	221
"Standard" (TEE) .....	227
Stress Indexes .....	228
Welds (WLD) .....	230
Concentrated weight (CW) .....	232
Concentrated Loads (FOR) .....	233
Anchor (ANC) .....	235
Support (SUP) .....	241
Translational Restraint (STS) .....	245
One-way restraint ( STS+, STS- commands) .....	249
Skewed Restraint (SRS) .....	252
Rigid Strut (STRT) .....	256
Guide Support (STG, STG-) .....	259
Spring Hanger/Support (SPR) .....	263
Rod Hanger (ROD) .....	268
Viscous Damper (DMP) .....	271
Snubber (SNUB) .....	277
Dynamic Limit Stop (DGAP) .....	283
Concentrated Transient Dynamic Load (DFRC) .....	286
Time History output /Travel indicator (TH_OUT) .....	288
Discontinuity stresses (STR_DISC) .....	291
<b>Part IX References</b> .....	<b>293</b>
<b>Part X Appendix I</b> .....	<b>293</b>
<b>Part XI Appendix II</b> .....	<b>294</b>
<b>Part XII Appendix III</b> .....	<b>298</b>
<b>Part XIII Appendix IV</b> .....	<b>300</b>
<b>Part XIV Appendix V</b> .....	<b>302</b>
1 Analysis according to PNAE Code .....	302
2 Analysis according to the Russian Boiler Code (RD).....	309

<b>Part XV</b>	<b>Appendix VI</b>	<b>311</b>
	1 Basic definitions.....	311
	2 Run of analysis, errors and warnings.....	313
	3 Results of analysis.....	319
	4 SH.DBS file structure.....	322
	5 Selection of springs from LISEGA Catalog.....	323
<b>Part XVI</b>	<b>Appendix VII</b>	<b>326</b>
<b>Part XVII</b>	<b>Appendix VIII</b>	<b>327</b>
<b>Part XVIII</b>	<b>Appendix IX</b>	<b>329</b>
<b>Part XIX</b>	<b>Appendix X</b>	<b>330</b>
<b>Part XX</b>	<b>Appendix XI</b>	<b>334</b>
	1 NC_3600.....	334
	2 NB_3600.....	337
<b>Part XXI</b>	<b>Appendix XII</b>	<b>340</b>
<b>Part XXII</b>	<b>Appendix XIII</b>	<b>348</b>
<b>Part XXIII</b>	<b>Appendix XIV</b>	<b>350</b>
<b>Part XXIV</b>	<b>Appendix XV</b>	<b>351</b>
<b>Part XXV</b>	<b>Appendix XVI</b>	<b>353</b>
<b>Part XXVI</b>	<b>Appendix XVII</b>	<b>355</b>
<b>Part XXVII</b>	<b>Appendix XVIII</b>	<b>359</b>
<b>Part XXVIII</b>	<b>Appendix XIX</b>	<b>363</b>
<b>Part XXIX</b>	<b>Appendix XX</b>	<b>367</b>
<b>Part XXX</b>	<b>Sample of analysis</b>	<b>370</b>
	1 Piping Data.....	370
	2 Seismic Load.....	371
	3 Input Data and Run of analysis.....	372

## 1 Abbreviations

Abnorm.	Abnormal Conditions
Fault.	Faulted Conditions (eg. <a href="#">LOCA</a> )
HE	High Energy (pipes)
HELB	High Energy Lines Break
HTEST	Hydraulic Test
LOCA	Loss of Coolant Accident
NOC	Normal Operation Conditions
OBE	Operating Basis Earthquake
PNAE	Rules and Regulations in the Nuclear Power Industry (Russian Nuclear Code)
SSE	Safe Shutdown Earthquake

## 2 Introduction

dPIPE 5 is Piping Stress and Flexibility Analysis Software Program used to analyze piping and structural systems subjected to static and dynamic loads.

The following types of analyses are performed under the set of specified loads:

### ***static analysis:***

- analysis of displacements, support reactions, internal forces and stresses in the piping system under the action of weight loads (distributed and concentrated) as well as internal pressure;
- analysis of displacements, support reactions, internal forces and stresses in the piping system under the action of thermal expansion loads;

### ***dynamic analysis:***

- analysis of response displacements, accelerations, support reactions, internal forces and stresses in the piping system under the action of seismic loads specified in the form of response spectra (analysis according to Response Spectrum Method, **RSM**). In order to determine the seismic response of the system, the Independent Support's Motion Analysis has been implemented in the software, i.e. the possibility of setting specific response spectra for various elevations of piping system anchorage to building structures;
- analysis of response displacements, accelerations, support reactions, internal forces and stresses in the piping system under the action of transient dynamic loads specified in the form of accelerograms (seismic loads) or time varying loads concentrated in the nodes of FE model (Time History Analysis, **THA**).

Stress evaluation of piping components is performed according to any of the following piping codes:

For Nuclear Piping:

- Russian Code PNAE G-7-002-86;
- ASME BPVC Code, Section III, Subsections NB, NC, ND
- NTD A.S.I. Sekce III, Příloha A, Hodnocení pevnosti zařízení a potrubí jaderných elektráren typu VVER, 2016 (Czech Code)

For Industrial Piping:

- Russian Boiler Code RD 10-249-98;

- ASME B31.1;
- ASME B31.4;
- EN 13480 "Metallic Industrial Piping"

A specially developed input data entry language is used for describing the piping system geometry and specifying its physical and mechanical characteristics. The software has a comprehensive error diagnostic system, a graphic interface for entering input data and viewing them as well as calculation data.

### 3 Software structure. File system

The dPIPE 5 software consists of individual program modules performing various analysis process stages. All program modules are interconnected via the common file system. Program modules of the dPIPE 5 software are listed below along with brief description of their purpose.



Designation	Description
DPC.EXE	Preprocessor. Input data entry and verification
LIST_BIN.EXE	Input Data listing generation program
DP5S.EXE	Static analysis module. It generates the Piping Calculation Model stiffness matrix and load vectors, solves the system of equations, defines the internal forces and deformations in elements, support reactions, as well as node displacement
DP5D.EXE	Dynamic analysis module. It calculates Piping Eigen Frequencies and Mode Shapes
POST.EXE	Post-processor. Printout of the results and check of the stresses to the Code compliance
Pipe3DV.EXE	View of Piping Calculation Model and the results in graphical form
WORKPAD.EXE	Text editor for Input Data editing and printout preview
Pipe3DV.CHM	Help file for the Pipe3DV program
<a href="#">DDE.EXE</a>	Spreadsheet for Input Data entry
dPIPE_5.CHM	Help file for the dPIPE 5 software
<b>Runtime libraries and auxiliary programs to the DDE spreadsheet:</b>	
DATALIB.DLL	
DATALIB.NET.DLL	
DATALIB.NET.RESOURCE.S.DLL	
GYMFCEXT.DLL	
HASP.DLL	
PL.DLL	
PLDRAW.DLL	
REGISTRY.DLL	
RES.DLL	

SERIALIZE.DLL	
SETUP_RES.DLL	
SPAWNER.EXE	
<b>Files containing databases and auxiliary information:</b>	
FMT_PRE.DBS	File with settings for printout of Input Data listing tables (in Russian)
FMT_PST.DBS	File with settings for printout of tables with the results (in Russian)
FMT_PRE_E.DBS	File with settings for printout of Input Data listing tables (in English)
FMT_PST_E.DBS	File with settings for printout of tables with the results (in English)
MAT.DBS	File with the materials and fatigue curve database
SH.DBS	File with the database for the spring hanger characteristics (see also <a href="#">Appendix VI</a> )
DMP.DBS	File with the database for High Viscous Damper (HVD) characteristics
BEAM.DBS	File with the database for beam element cross-section properties
PIPE.DBS <sup>1)</sup>	File with the database for standard pipe and bend properties
SOLV.DBS	File with the set of pre-defined specifications for analysis and post-processing
VLV_OTT.DBS	File containing Database with allowable loads on valve's nozzles in accordance with General Technical Requirements NP-068-05, <a href="#">[REF 14]</a>
SUP_LDS.MDB (located in DB folder)	File with allowable loads on piping supports (in Microsoft Access format), see. <a href="#">Appendix XII</a> for description
DP.BAT	Run complete analysis in batch mode
SOLV.BAT	Run solution module in batch mode
CLEAR.BAT	Clearing the working directory
<b>UTILS folder:</b>	
R2DP_N.EXE, R90_2_DP5.EXE, R93_2_DP5.EXE <sup>2)</sup>	Program for Input Data conversion from RAMPA format into dPIPE 5 format
DP2DP5.EXE <sup>3)</sup>	Program for Input Data conversion from the previous versions of dPIPE formats into dPIPE 5 format
MAT_DP_OLD.DBS	File with the database for materials (for previous versions of dPIPE)
SH.DBS	File with the database for spring hanger characteristics (for previous versions of dPIPE)
DMP.DBS	File with the database for <a href="#">HVD</a> characteristics
EN-US and RU-RU folders contain runtime libraries and help files for the English and Russian program interfaces respectively	

- 1) If the content of the database depends on the CODE used for analysis, this data should be preceded by **\$SET CODE** command. File pipe.dbs could also contain the parameter **DOC** for the certain document. This information is used for the following [filtering](#) of the data. Sample: \$SET CODE ='PNAE' DOC="OST24 AUSTENIT"

In databases, for PNAE and GOST Codes, the \$SET CODE command is set with values according to the table:

CODE	mat.dbs	pipe.dbs	solv.dbs
PNAE	\$SET CODE = 'PNAE'	\$SET CODE = 'PNAE'	\$SET CODE = 'PNAE'
GOST-59115-A	\$SET CODE = 'GOST-59115'		

- 2) For the conversion data from the RAMPA program into dPIPE 5, it is possible to use the  icon located in the right corner of the upper toolbar. In doing so, the RAMPA-93 and RAMPA-90 files with Input Data should have the extension ".dat" and ".nml" respectively;
- 3) For the conversion data from the previous versions of dPIPE into dPIPE 5, it is possible to use the  icon located in the right corner of the upper toolbar. In doing so, the files with Input Data corresponding to the previous versions of dPIPE should have the extension ".dat".

The following table contains a description of the file system to be used in the dPIPE 5 software. The file type is indicated in the "Note" column. ASCII corresponds to text files; BIN corresponds to internal binary files.

File name	Description	Originator	Use	Note
NAME.DP5	Input data (piping system geometry, properties of materials, specification for analysis and post-processing of the results)	User, DDE, conversion programs	DPC, DDE	ASCII
NAME.BIN	File with the database for Piping Calculation Model and the results	DPC	DP5S, DP5D, LIST_BIN, POST, PIPE3DV	BIN
NAME.BIN 2	Intermediate file with the static analysis results	DP5S	POST, DP5D	BIN
NAME.BIN 3	Intermediate file with the dynamic analysis results	DP5D	POST	BIN
NAME.OUT 1)	Input data printout	DP_LIST	User	ASCII
NAME.RES 1)	Printout of the results	POST	User	ASCII
NAME.SUP 1)	Summary tables of loads on supports, equipment and valves	POST	User	ASCII
NAME.INF	Summary tables of loads (in raw format ) on supports for all load cases	POST	User	ASCII

1)Content of files with input data listing (\*.OUT) and analysis results (\*.RES and \*.SUP) may be adjusted to specific formats for numbers and text in Tables headers/footers through the use of files-templates: pre\_fmt.dbs for input listing and pst\_fmrt.dbs for analysis results. Default locations of

these files are “ru-RU” and “en-US” folders (depending on interface language). Location could be changed either through the interface [Options/Reports/Templates](#) or by command [DBF](#).

## 4 PC configuration requirements

The following PC configuration is needed for running the dPIPE 5 software:

- Operating system: Windows 7 or higher;
- .NET Framework software development and execution environment, Version 4.7.2 or higher
- Graphics Card with OPEN GL and DirectX support

## 5 Software installation

In order to install the dPIPE 5 software, it is necessary to run the installation program DP5\_XXSETUP.EXE (XX - is the actual number of dPIPE Release) and then follow the installation program instructions.

For the proper work of dPIPE, version 5.23 and higher, it is necessary to have .NET Framework program execution environment, Version 4 or a later version<sup>1)</sup>. If this software is not installed on the computer, then, in case of the Internet access being provided, .NET Framework 4 will be installed automatically from the Microsoft.com web site during installation of the dPIPE software. If the Internet access is not provided, then before proceeding to dPIPE installation, it is necessary to install .NET Framework 4 independently. .NET Framework 4 software is free. The installation program can be downloaded from the following web site address:  
<http://www.microsoft.com/ru-ru/download/details.aspx?id=24872>.

Note:

- 1) You can find out the actual version of .NET Framework installed on your computer as follows:
  1. Open the Start menu, select Run.
  2. In the text field, Open enter regedit.exe.
  3. In the Register Editor, open the following subsection:  
**HKEY\_LOCAL\_MACHINE\SOFTWARE\Microsoft\NET Framework Setup\NDP**  
The versions installed are listed in the NDP subsection:

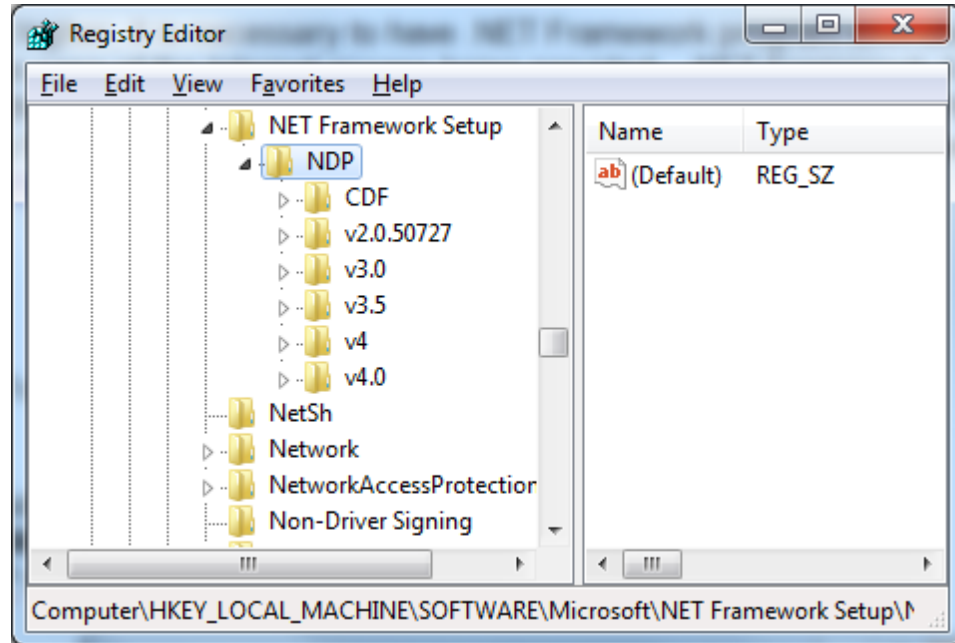

## 6 Protection keys and License Management

dPIPE employs Software Licensing and Protection system SENTINEL™. The program can work with hardware keys HL (inserted into the computer's USB port), as well as with software SL keys. Type of Protection key may be a Single User License or Network License. Depending on the type of key different procedures for installation/upgrade are described below.

**To the attention of system administrators:**

**After installing the [license manager](#) you can get information and access to management to the Sentinel keys that are currently present on the network, including the locally connected Sentinel keys with a help of the Sentinel Admin Control Center (<http://localhost:1947>).**

[User hardware Key HL](#)

[Network Hardware Key HL-NET](#)

[User Software Key SL-UserMode](#)

[Network Software Key SL-AdminMode](#)

[dPIPE in Sub-Network](#)

[Sentinel SL License Transfer between two PCs](#)

### User hardware Key Sentinel HL Pro DL

**User hardware Key Sentinel HL Pro DL:** no special installation procedure is required. The Key is supplied to the User with an embedded License. To update the License file "\*.v2c" is sent from Developer to the User. This file should be pointed for the command "Update License":

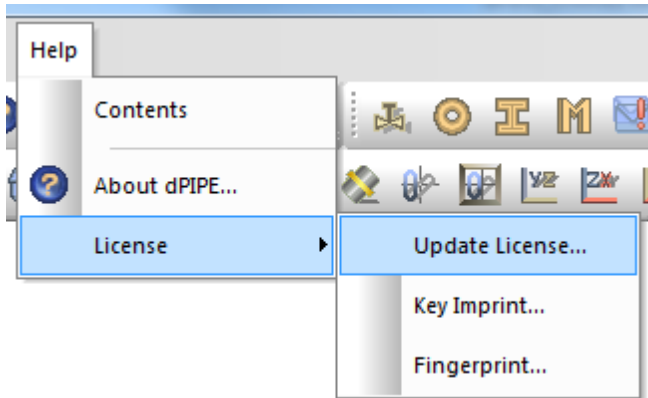

## Network Hardware Key HL-NET

**Network Hardware Key HL-NET.** This Key is supplied to the User with an predefined number of the Licenses. The license manager can be installed using the KeyMan program, which is located in the Sentinel sub-folder under the dPIPE installation root directory. The Sentinel sub-folder is created if the "Server utilities" option was selected when installing the program. Server Utilities is a stand-alone option and can be installed separately from dPIPE, for example on a server.

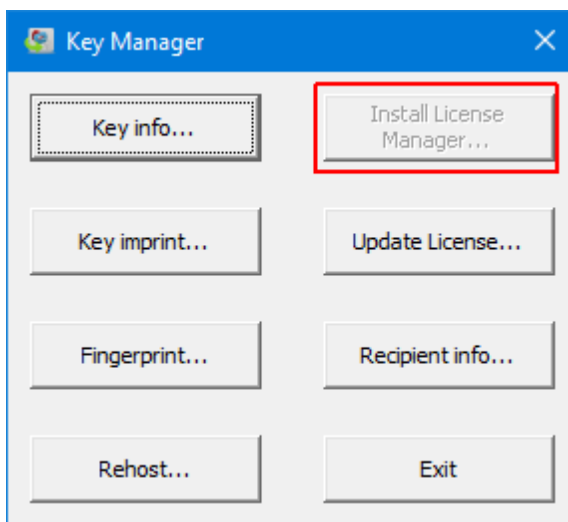

## User Software Key SL-UserMode

**User Software Key SL-UserMode.** Use "Help-License-Fingerprint" command to generate "Client to Vendor" file \*.c2v. This file should be sent to the Developer. File \*.v2c obtained in response allows activate license through "Help-License-Update License" command.

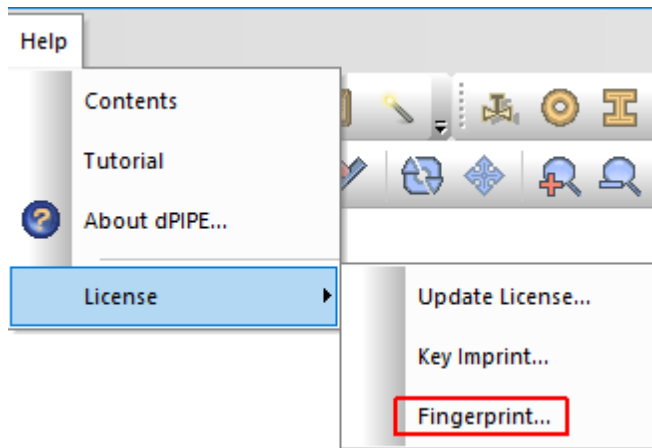

In response, the Developer sends a \*.v2c file, which allows you to activate the license through the item "Update license". When changing/updating a license, the procedure is the same as for a [hardware key](#).

**Attention: before performing any operations related to the upgrade of operating systems or hardware on computers/servers on which user or network software licenses are installed, these licenses should be transferred to another computer, see chapter "[Sentinel SL License Transfer between two PCs](#)"**

## Network Software Key SL-AdminMode

**Network Software Key SL-AdminMode.** [License Manager](#) should be installed on the Server. Then use Key Manager software and run command "Fingerprint":

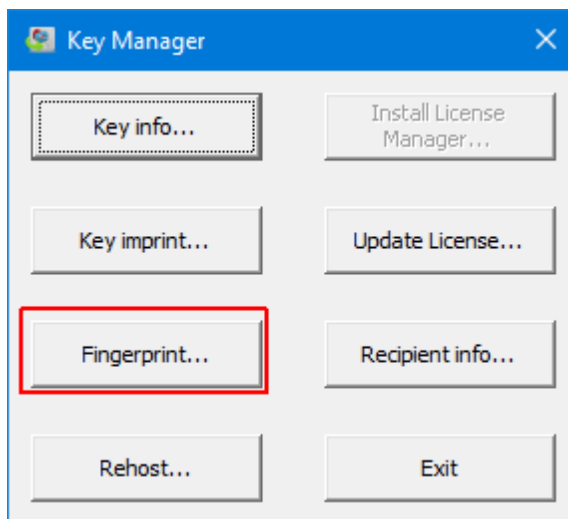

Generated \*.c2V file should be sent to the Developer. File \*.v2c obtained in response allows activate license through "Update License" command of Key Manager.

**Attention: before performing any operations related to the upgrade of operating systems or hardware on computers/servers on which user or network software licenses are installed, these licenses should be transferred**

to another computer, see chapter "[Sentinel SL License Transfer between two PCs](#)"

## dPIPE in Sub-Network

### Work with dPIPE in Sub-Network:

To use SENTINEL keys across subnets one has to create a text file «hasp\_82556.ini» with the following content:

```
[NETWORK] ; Section name, mandatory string
BROADCASTSEARCH = 0 ; switching off broadcast search of the key
SERVERADDR = <Server Name> ; The IP address or name of the server where the license
manager is installed
DISABLE_IPV6 = 1 ; switching off the use of IPv6
```

This file should be placed on the Client PC in the following folder:

Type of application	Directory
Desktop (Windows Vista/7 or later)	%LocalAppData%/SafeNet Sentinel/Sentinel LDK/
Desktop (Windows XP)	%UserProfile%/Local Settings/Application Data/SafeNet Sentinel/Sentinel LDK/
Service (LocalSystem) x64 operating system	%windir%\SysWOW64\config\systemprofile\AppData\Local\SafeNet Sentinel\Sentinel LDK\
Service (LocalSystem) x86 operating system	%windir%\System32\config\systemprofile\AppData\Local\SafeNet Sentinel\Sentinel LDK\
Service (Network)	%windir%\ServiceProfiles\NetworkService\AppData\Local\SafeNet Sentinel\Sentinel LDK\

To connect a specific application with certain protection key, one has to enter in the Register the record ProtectionKeyId (QWORD type) with the value equal to the number of KEY. Address of the Registry Entry is:

HKEY\_LOCAL\_MACHINE\SOFTWARE\Wow6432Node\CVS\**ApplicationName**\Settings, where ApplicationName depends on the addressed application: "dPIPE 5.XX" (5.XX - version number, i.e. 5.27), "Tcalc", «CVSpec-TH», "G-FRC 2.0":

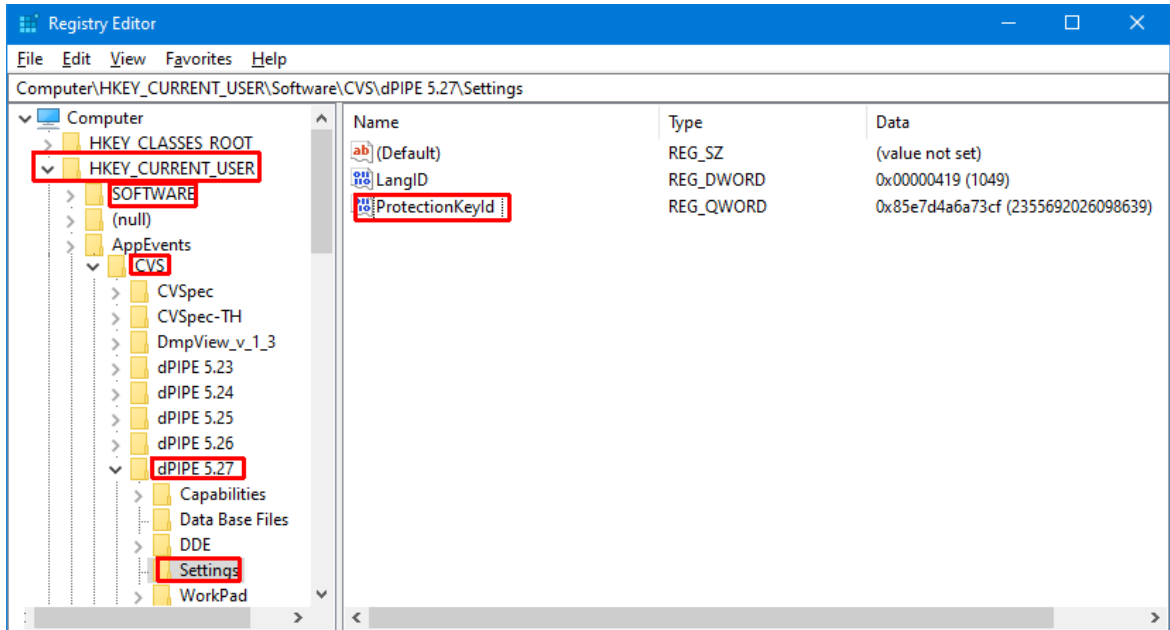

## Sentinel SL License Transfer between two PCs

### Sentinel SL License Transfer between two PCs

The software license key may be transferred between two PCs if the corresponding option is activated. If the option is not activated, then before transferring it is necessary to activate it by updating the key. Let's denote **S**(Source) the computer from which the key is transferred, and **R**(Recipient) the computer to which the key is transferred.

The procedure:

1. Launch the KeyMan program on computer R. By clicking the "Recipient Info" button, you will get a file with information about computer R:

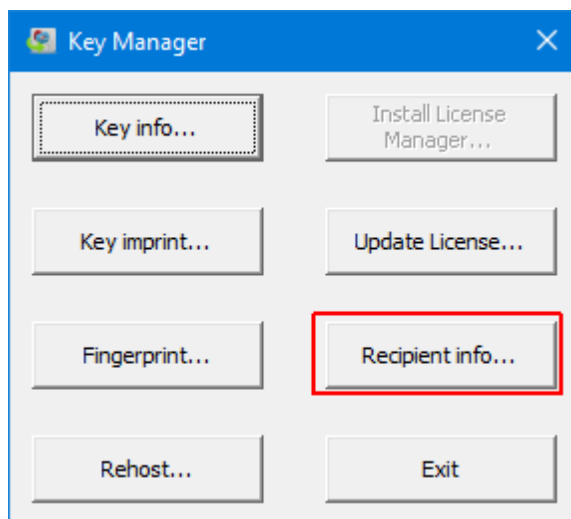

If Sentinel License Manager is not installed on the computer, the program will prompt you to install it, since if you transfer the network key, it must be installed before receiving the information file.

- The file received in step 1 should be transferred to computer **S**. Run the KeyMan program on PC "**S**" and click the "Rehost" button

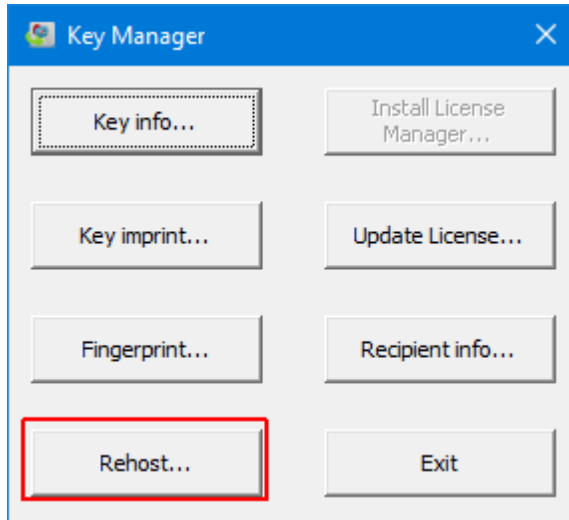

If the computer does not have keys that can be transferred, a message will be displayed. If there are several keys, the program will prompt you to select one from the list. In the dialog that appears, open the file transferred from the "R" computer. A file will be created to transfer the key with the name "KeyNumber.h2h" and the key will be deleted from computer S. The file must be saved using the dialog that appears.

- Copy "KeyNumber.h2h" file to computer R. Run the KeyMan program if it was closed after completing step 1 and click the "Update License" button.

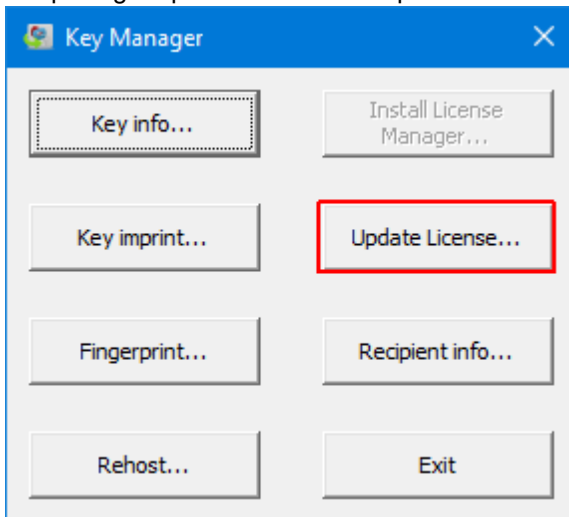

In the appeared dialog select the file type "Host-to-Host" and open the file. If successful, a corresponding message or error message will be displayed if it occurred during the transfer process.

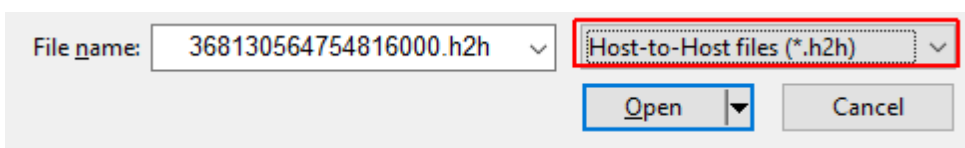

**IMPORTANT!**

**Before performing any actions to transfer the key, you must make sure that the same version of the License Manager is installed on both PCs and, if necessary, update the driver. This can be done using the KeyMan program included in the dPIPE distribution (Sentinel folder).**

**During the process of borrowing licenses, starting from the creation of the ID file on the acceptor and until the moment the license is applied from H2H, it is highly recommended not to update or reinstall the drivers on both PCs.**

## 7 DDE spreadsheet

DDE spreadsheet serves as the interface between entering the Input Data, running the analysis and viewing the results of the dPIPE 5 software. Input Data can be entered in two modes: *active mode* – with dynamic tracing and displaying the piping system being composed and *passive mode* – without tracing and input syntax check.

### Spreadsheet interface

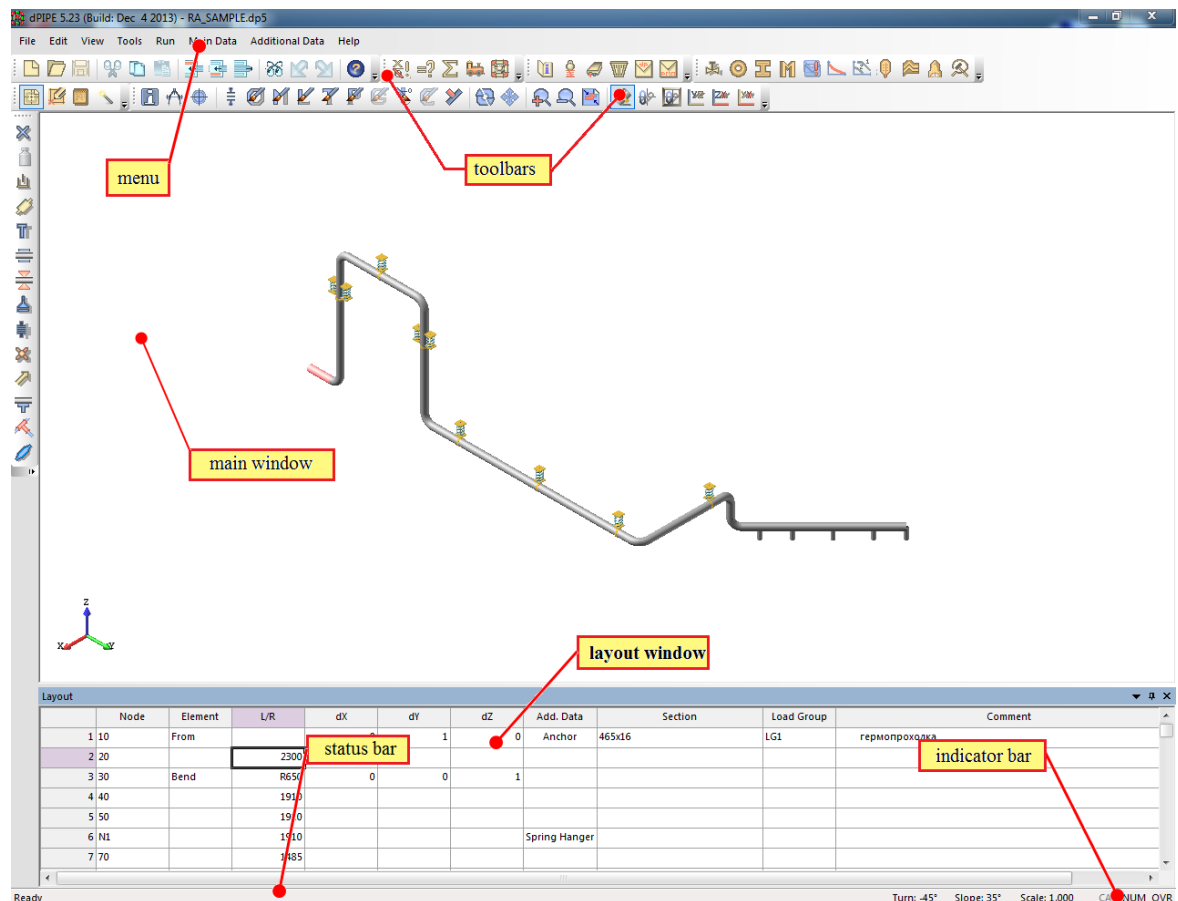

The **main window** of the program displays either the graphic model the piping system, or the model description in the form of a set of commands of the dPIPE software [input data entry language](#).

In case of right click in the main graphic window area, the **context menu** appears, which allows to execute the following set of operations:

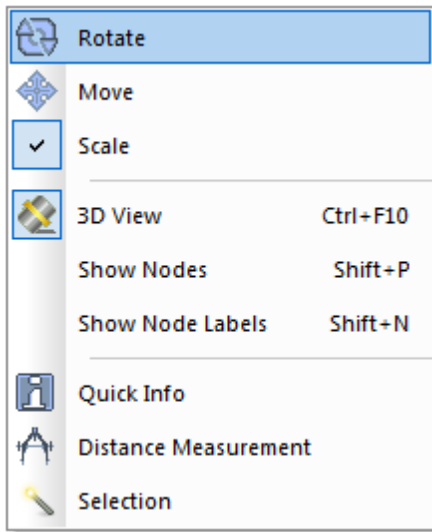

**Rotate** (): rotation of the model by means of the mouse with the left button being pressed;

**Move** (): movement of the model over the screen by means of the mouse with the left button being pressed;

**Scale**: mode for selecting a window by the mouse in order to zoom in (select from top downward) or zoom out (select from bottom upward) the model part being viewed. Zooming can also be performed

by means of the mouse wheel. In addition, the following icons can be used for zooming:  - zoom

in with centering,  - zoom out with centering (centering is carried out with respect to the part of the screen, at which the left click is performed);

**3D View** (): toggle between 3D Rendered View and non rendered view (CTRL-F10);

**Show nodes**: show node's symbols (Shft-P);

**Show Node Labels**: toggle to show/hide node's labels (Shft-N);



**Quick Info** (): mode, at which a click on the highlighted element/node calls the information window:

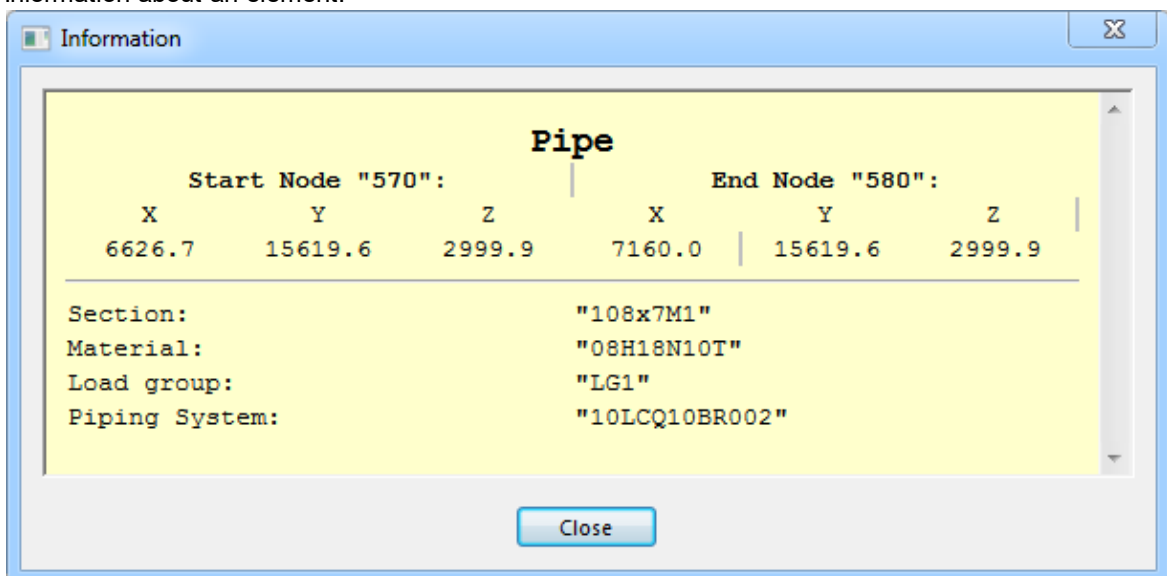

Information about an element:

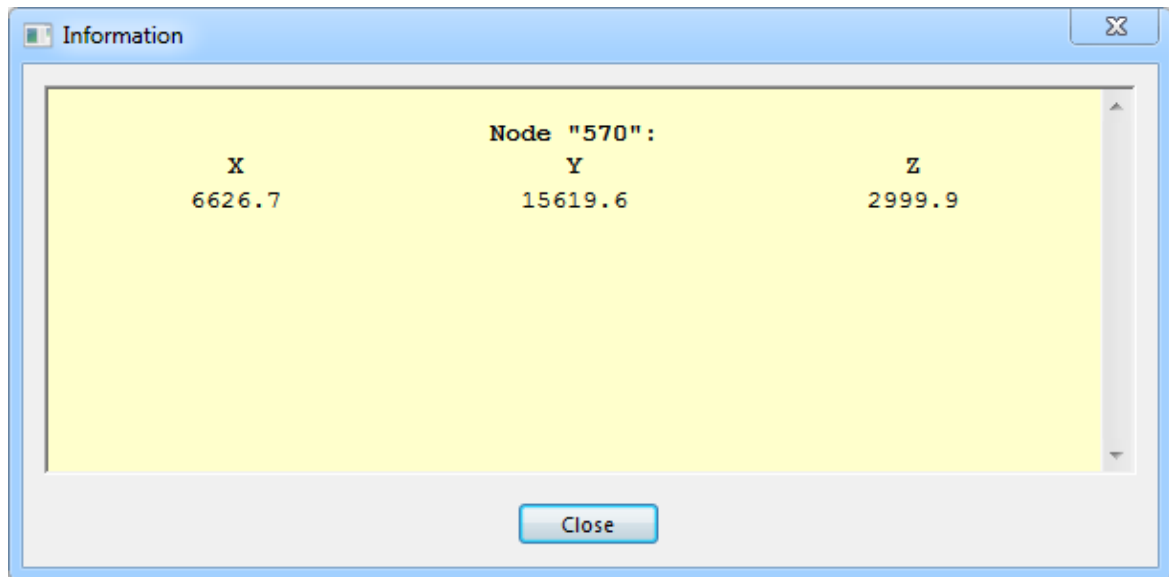





Information about a node:



 **Distance Measurement** (  ): mode allowing to measure the distance between any two nodes of the model. Hold «CTRL» key for temporary switching between this or “quick info” mode to navigation

 **Angle measurement** (  ): measuring of the angle between two straight elements

 **Measuring angles** (  ) between the centerline of a straight element and its projections on the XOY, YOZ, XOZ planes

 **Selection** (  ): mode allowing to select a part of the model for subsequent operations to copy, paste, modify and delete the piping segments selected (see "[Copy, paste, modify and delete piping segments](#)").

**Layout input window** containing the table for entering Input Data has the following fields:

Node – identification name of the model node;

Element – type of the element; the element type selection is carried out either by double click in the corresponding cell, or by pressing F2 key:

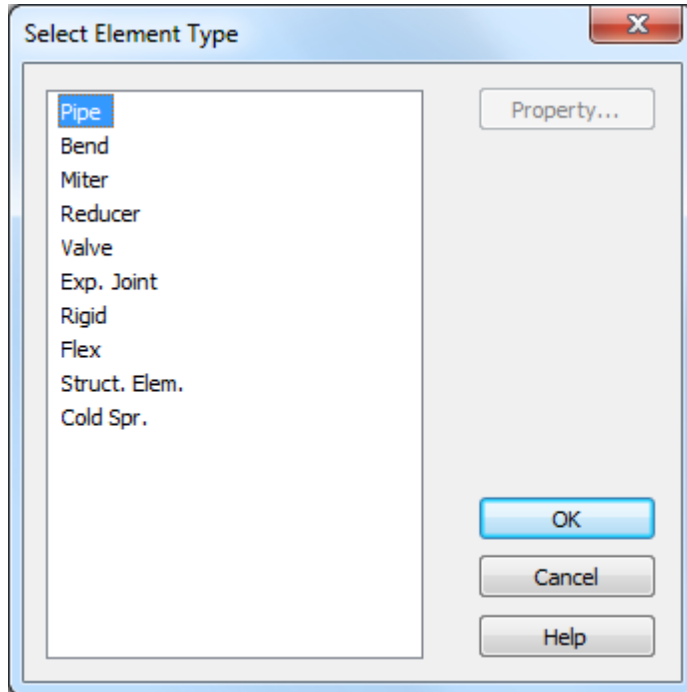

The element types in the menu are connected with dPIPE commands as follows:

Menu	Description	Commands
Arc	command for bend breakdown	<a href="#">BEND (2)</a>
Bend	bend-1	<a href="#">BEND (1)</a>
Cold Spr.	cold spring	<a href="#">CS</a>
Exp. Joint	expansion joint	<a href="#">EJ</a> , <a href="#">EA</a> , <a href="#">ET</a> , <a href="#">EH</a> , <a href="#">EG</a>
Flex	flexible element	<a href="#">FJ</a>
From	beginning of branch	<a href="#">FROM</a>
Miter	sector elbow	<a href="#">MTR</a>
Pipe	straight pipe	<a href="#">PIPE</a>
Reducer	reducer	<a href="#">REDU</a>
Rigid	rigid link	<a href="#">RX</a> , <a href="#">RP</a>
Struct. Elem.	beam	<a href="#">S</a>
Valve	valve	<a href="#">VALV</a> , <a href="#">V1</a> , <a href="#">V2</a>

Additional editing of the element's properties is carried out from the context menu with selection of the "Properties" item:

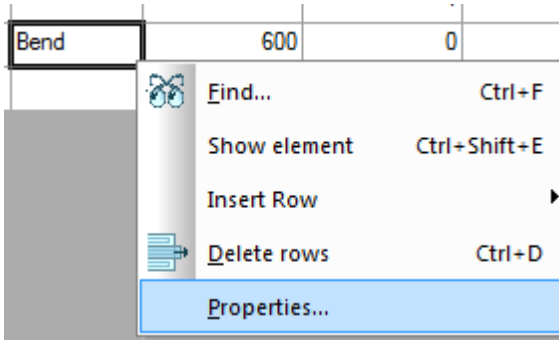

**L/R** – length of element/bend radius;

**dX, dY, dZ (Fi, Teta, R)** – direction of the element (to be specified in the Cartesian coordinate system or in the spherical coordinate system). Toggle between these modes is performed either by double clicking on the corresponding table headings or from the context menu (right click) with selection of the "Show in Column..." item:

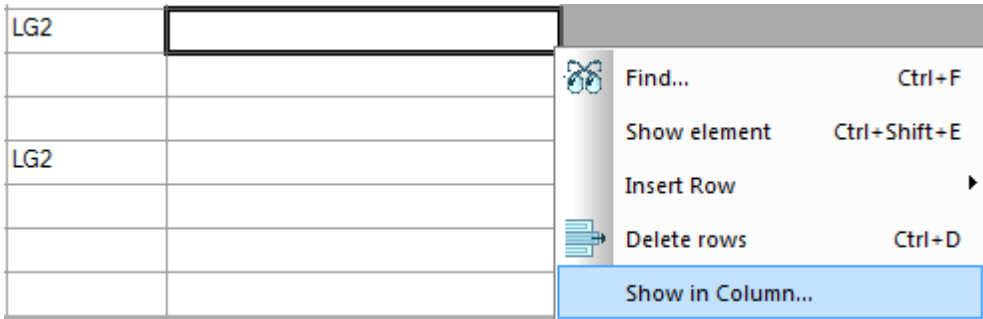

**Additional data** – data related to the model nodes (supports, concentrated parameters, tees, etc.). The data type selection is performed either by the click in the corresponding cell, or by pressing **F2** key:

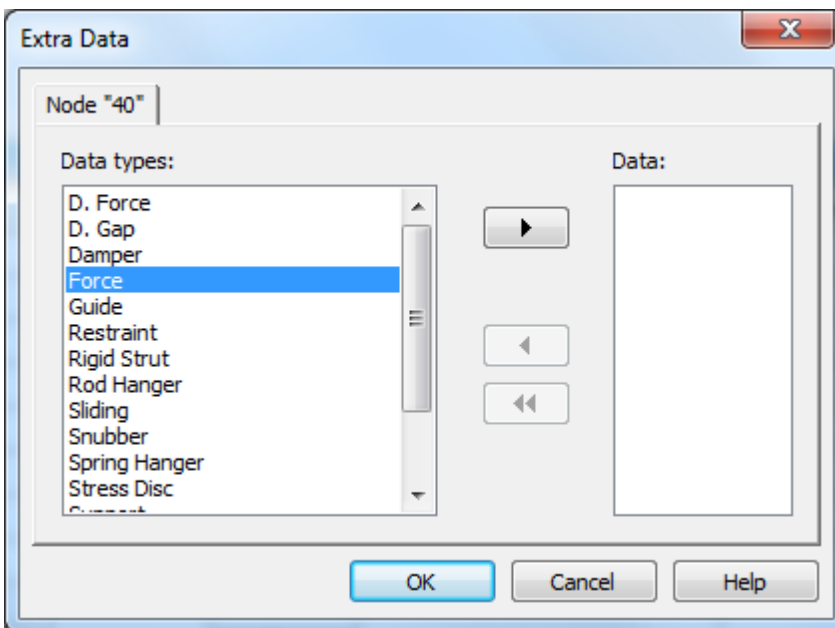

The types of additional data in the dialogue appeared are connected with the dPIPE commands as follows:

Dialogue	Description	Commands
----------	-------------	----------

Anchor	anchor support	<a href="#">ANC</a>
D. Force	nodal dynamic force	<a href="#">DFRC</a>
D. Gap	dynamic stop with gap	<a href="#">DGAP</a>
Damper	damper	<a href="#">DMP</a>
Force	nodal static loads	<a href="#">FOR</a>
Guide	guide support	<a href="#">STG, STG-</a>
Restraint	unidirectional transverse or rotational support	<a href="#">STS, SRS, STS+/-</a>
Rigid Strut	rigid strut	<a href="#">STRI</a>
Rod Hanger	rigid hanger	<a href="#">ROD</a>
Sliding	sliding support	<a href="#">STZ, STZ-</a>
Snubber	dynamic snubber	<a href="#">SNUB</a>
Spring Hanger	spring hanger/support	<a href="#">SPR</a>
Stress Disc.	additional temperature stresses	<a href="#">STR_DISC</a>
Support	6-component support	<a href="#">SUP</a>
TEE	tee	<a href="#">TEE</a>
THA Out	output of the transient response/displacement indicator	<a href="#">TH_OUT</a>
Weight	nodal weight	<a href="#">CW</a>
Weld	weld	<a href="#">WLD</a>

Editing the characteristics of the additional data is carried out either from the context menu with selection of the **"Properties"** item:

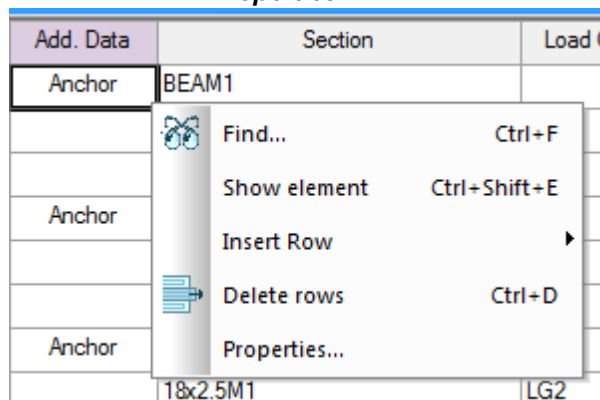

or by double click in the additional data window.

**Section** – name of the piping system cross-section ([PIPE](#) command) or name of the cross-section for the beam element ([BEAM](#) command); the selection of the cross-section is performed by pressing on **F2** key in the corresponding cell or by double left click.

**Load Group** – name of the load group of the piping segments; the selection of the piping system group is carried out by pressing on **F2** key in the corresponding cell or by double left click (see also [OPVAL](#) command).

**Comment/Name** – user's comments (any data following the "semicolon" character in the Input Data file line. In addition, this column serves for determination of the [identification name](#) of the piping segment. To toggle between the display modes is performed similar to the element direction.

**Status bar** contains information relating to the current line on possible errors during the entry of input data.

**Indicator bar** displays the status of keyboard keys: capital letters (CAPS), insert mode (INS), numbers input mode (NUM), as well as the parameters of the current view in the main window. By double clicking on the bar a dialog appears that provides to change/specify the desired settings + change the relative scale of the piping diameter (option is useful when displaying a long lines of small bore tubes; shortcuts: CTRL + GREY "+" / CTRL + GREY "-"):

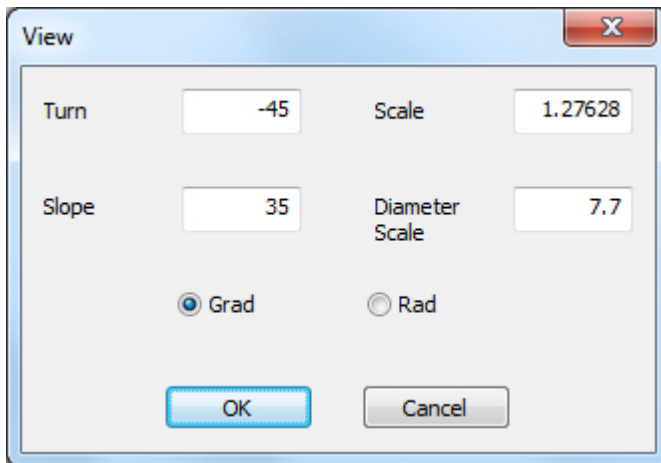

## Spreadsheet navigation

The connection between the main program window and the layout input window is performed in the "[active](#)" mode as follows:

1. During navigation over the spreadsheet lines the corresponding elements are highlighted and blink:

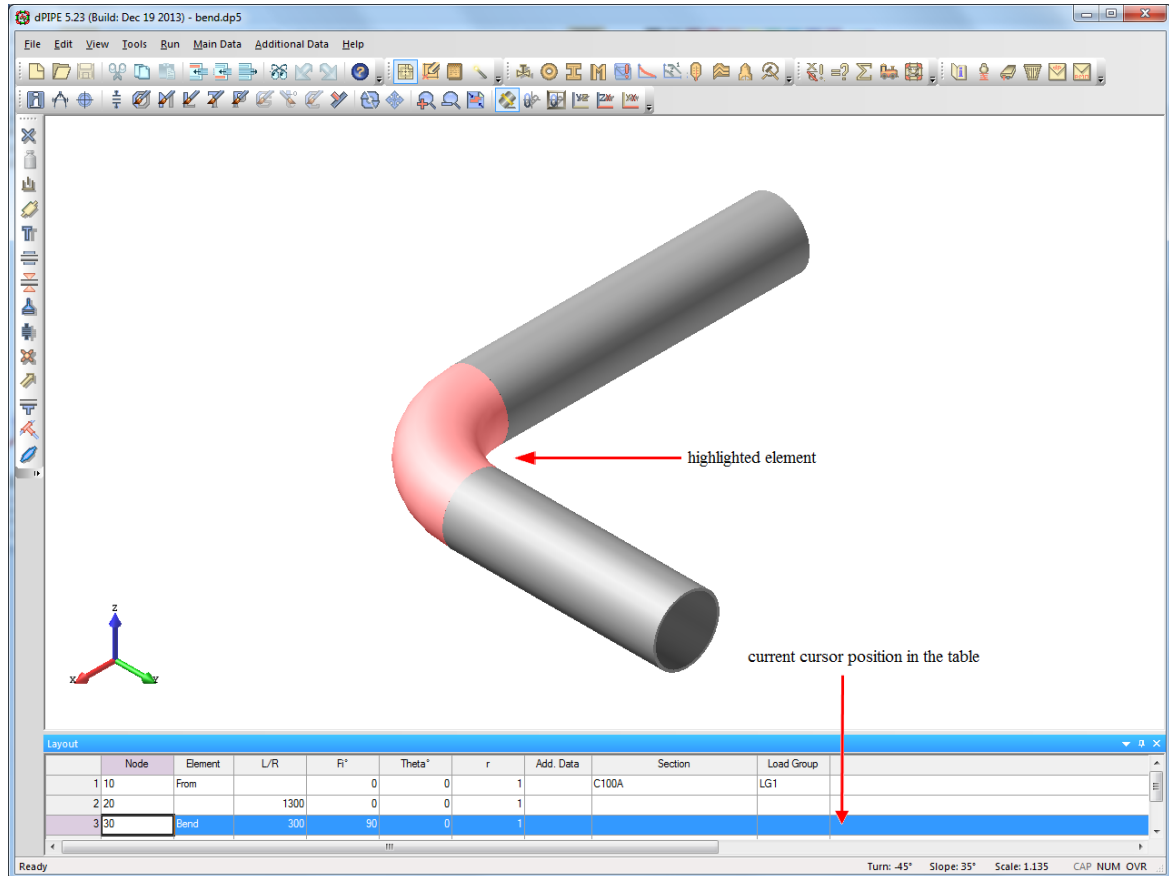

The blink rate could be adjusted on the "[display options](#)" page, in the field "Current element blink rate".

- If only a part of the model is shown on the screen, then during navigation over the spreadsheet lines the synchronization occurs between the current position of the cursor in the spreadsheet and the model area being displayed. This option can be disabled by removing the corresponding check mark on the "[display options](#)" page (flag "Auto position on current element");
- By simultaneously pressing the "Shift" key and double-clicking the left mouse button on an element in the graphic window, there will be either shifting from the graphic window to the corresponding row of the table, or calling up the corresponding dialog of the properties of the element or support. A convenient key combination could be set up in the "[display options](#)" window (group box "[Shift + double-click on the element](#)").

## Partial visualization of the model

When F4 key is pressed, the following dialog will appear:

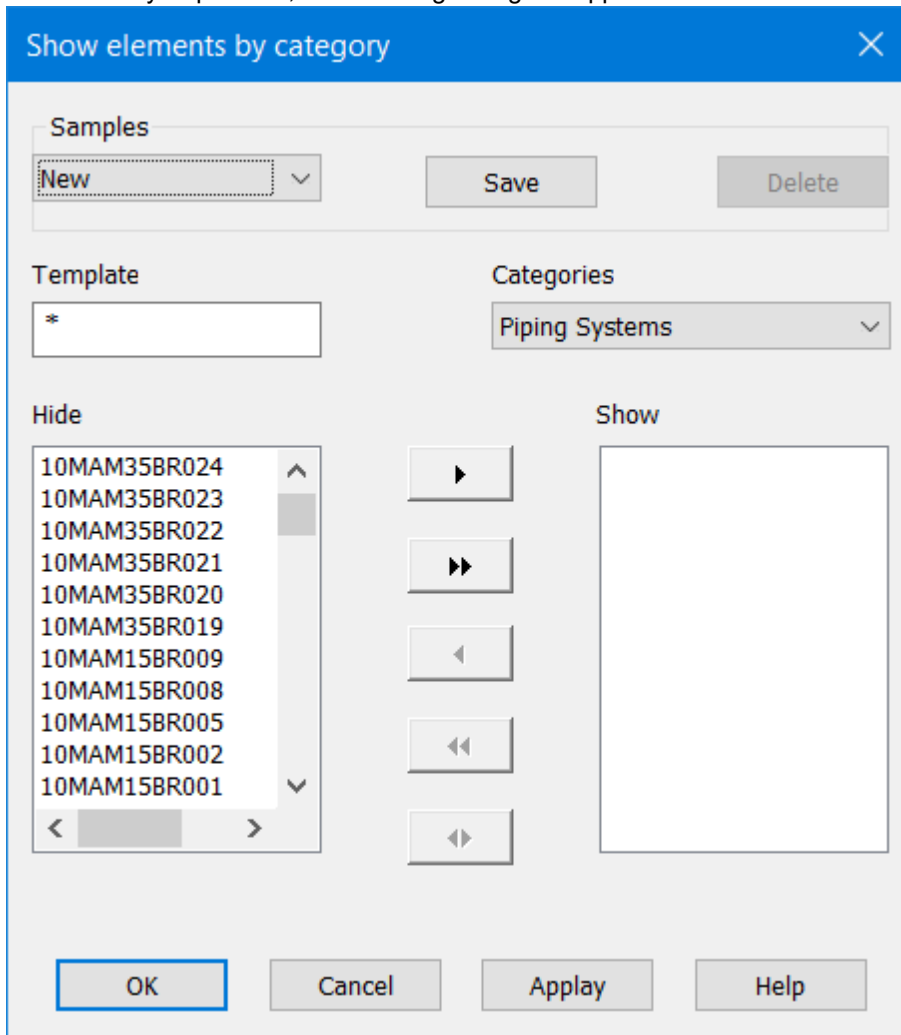

The "Filter" field is designed for displaying some elements out of the whole list according to the mask specified. For example, if \*MAM37 mask is entered, then the dialog will get the following view:

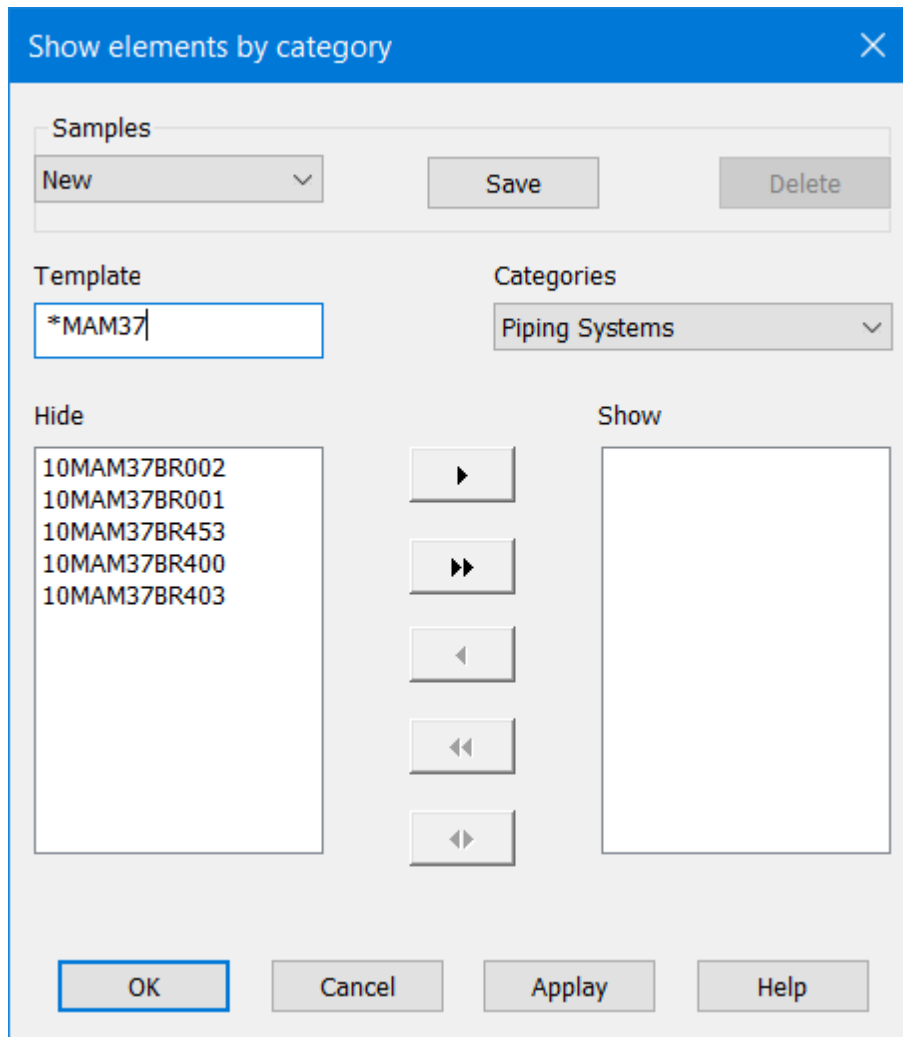

The "Categories" list contains typical features for grouping the piping segments:

- by piping segment name ([name](#) parameter);
- by cross-sections (command [PIPE](#));
- by materials (command [MAT](#));
- by load groups (parameter [LG](#) of the command [OPVAL](#));
- by seismic support groups (parameter [GROUP](#) of the command [SPEC](#));
- by the parts marked as "small-bore pipes" (parameter [SBP](#), see. [Appendix XV](#))
- by branches not connected by a common node or parameter [CNODE](#):
- by the parts highlighted with use of selection tool  [Watch Video](#) ;
- by the parts assigned to different seismic categories in accordance with NP-031 (parameter [SCTG](#));
- by sections assigned to different safety classes ([CLS](#) parameter, calculations according to ASME NB/NCD)

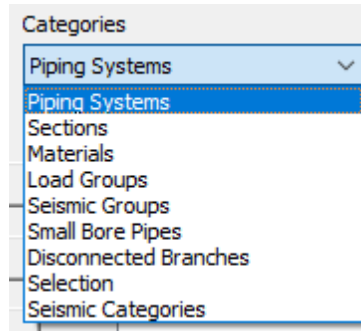

Groups of the elements belonging to some category are displayed in the left or right part of the dialog ("Hide" and "Show" fields). Depending upon the groups of elements selected the model can be displayed partially:

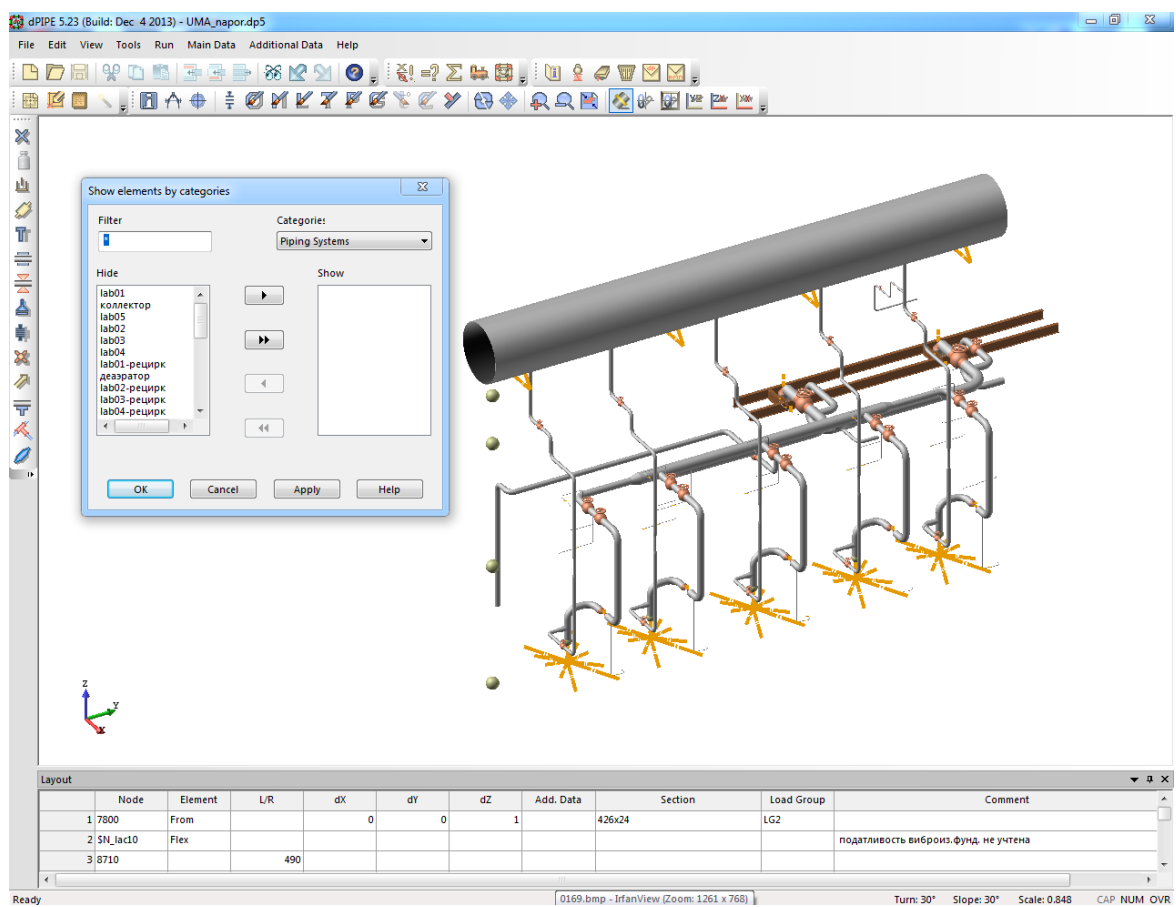

before selection

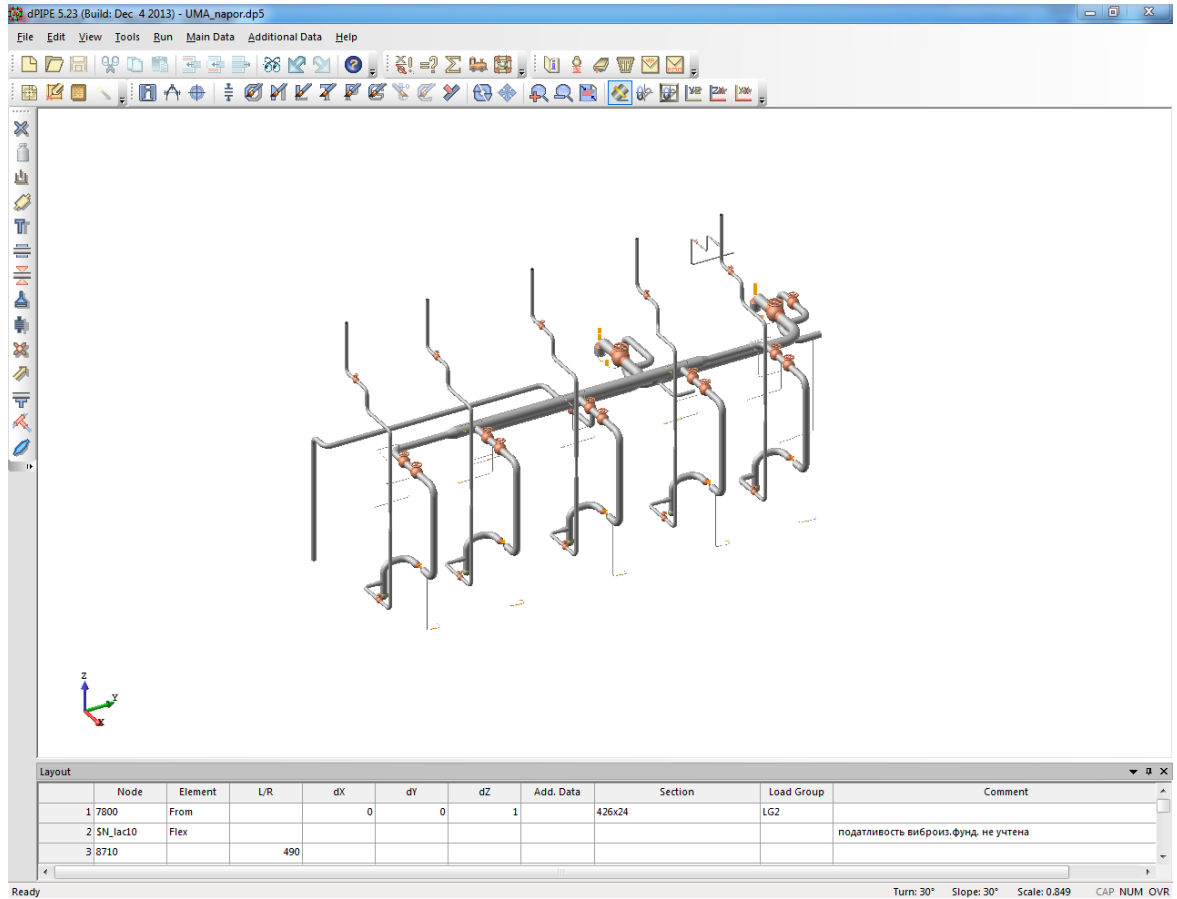

### after selection

The toggle between the partial and the whole model is performed by pressing the SHFT-F4 key combination.

For "**Cross-sections**" category, apart from the filter adjusted to the cross-section names, it is possible to use a filter by the value of outside piping diameter :

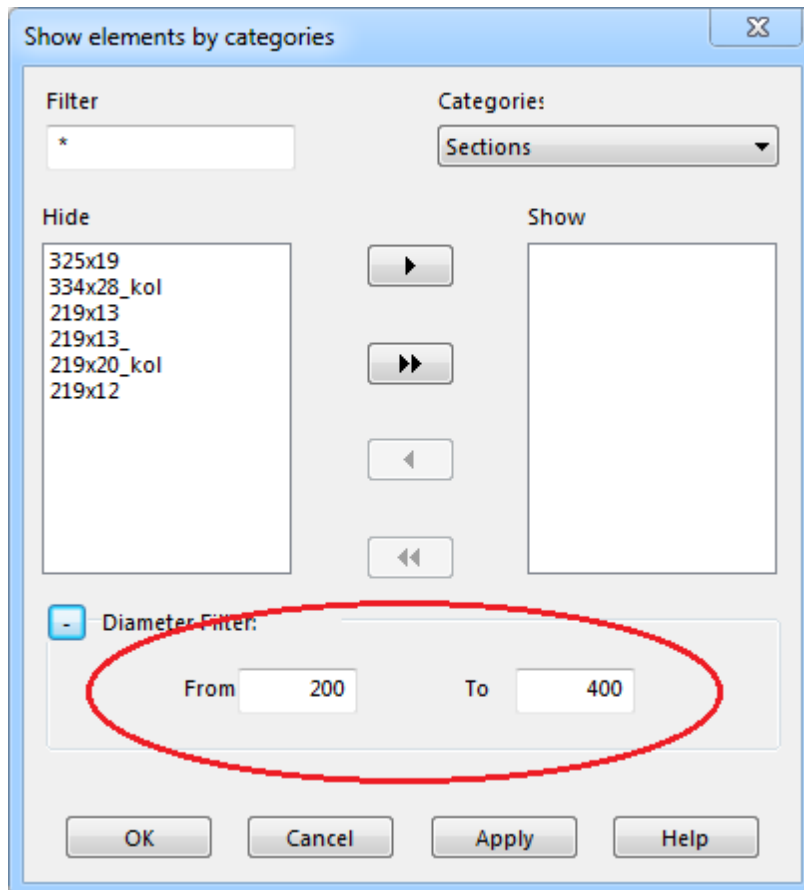

The selected part of the calculation model can be saved under a custom name and accessed both during the current session and in subsequent sessions of working with the model. Information about the selected sections is added to the file \*.dp5 after the command [END OF DATA](#).

Watch Video

## Copy, paste, modify and delete piping segments

For operations with a portion of the model, it is necessary to select the required segment by means of the tool  located on the "[Piping](#)" toolbar, which is also accessible from the mouse [context menu](#). It can be done by means of computer mouse, or by selecting the segment by frame, or by left click on the required element. During the selection operation the following rules are valid:

- single left click - only one elements will be marked. With repeated click the selection will be canceled;
- left click with simultaneous holding the **SHIFT** key - the whole branch will be marked;
- when the **CTRL** key is held, the elements will be added/excluded from the set that was marked before.

The selection operations can be interrupted for any other operations related to spreadsheet navigation and resumed after repeated pressing the  key.

The following operations can be performed with the model part selected:

- Modify:
  - name of the segment;
  - cross-section;
  - material;
  - load group;
  - Safety Class;
  
- Delete the elements selected as spreadsheet lines (at that the program will interpret such operation as the deletion of lines in the text file, i.e. if the beginning of the branch line falls into the sample, then the current branch line will "adhere" to the previous one, which involves modification of the whole model geometry)
  
- Delete the elements selected and fix the model; in doing so, the whole geometry remains unchanged
- Renumber the nodes of the model part selected
- Turn the model part about the global Z axis
- Mirror the model part selected with respect to the XZ or YZ plane

This list of operations is accessible either from the mouse [context menu](#) or via the "[Edit/Modify](#)" menu item

The model part selected can be copied for subsequent pasting either into the current model or into any other model. Copying is performed by means of the **CTRL-C** key combination or from the "[Edit/Copy](#)" menu. When copying it is necessary to specify the base node, in respect of which the subsequent paste of the segment:

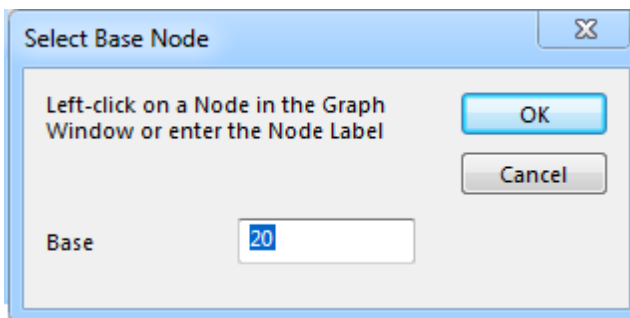

The segment copied can be pasted by means of the CTRL-V key combination or from the Edit/Paste menu. In doing so, a window with the image of the model part copied and the paste dialog box will appear :

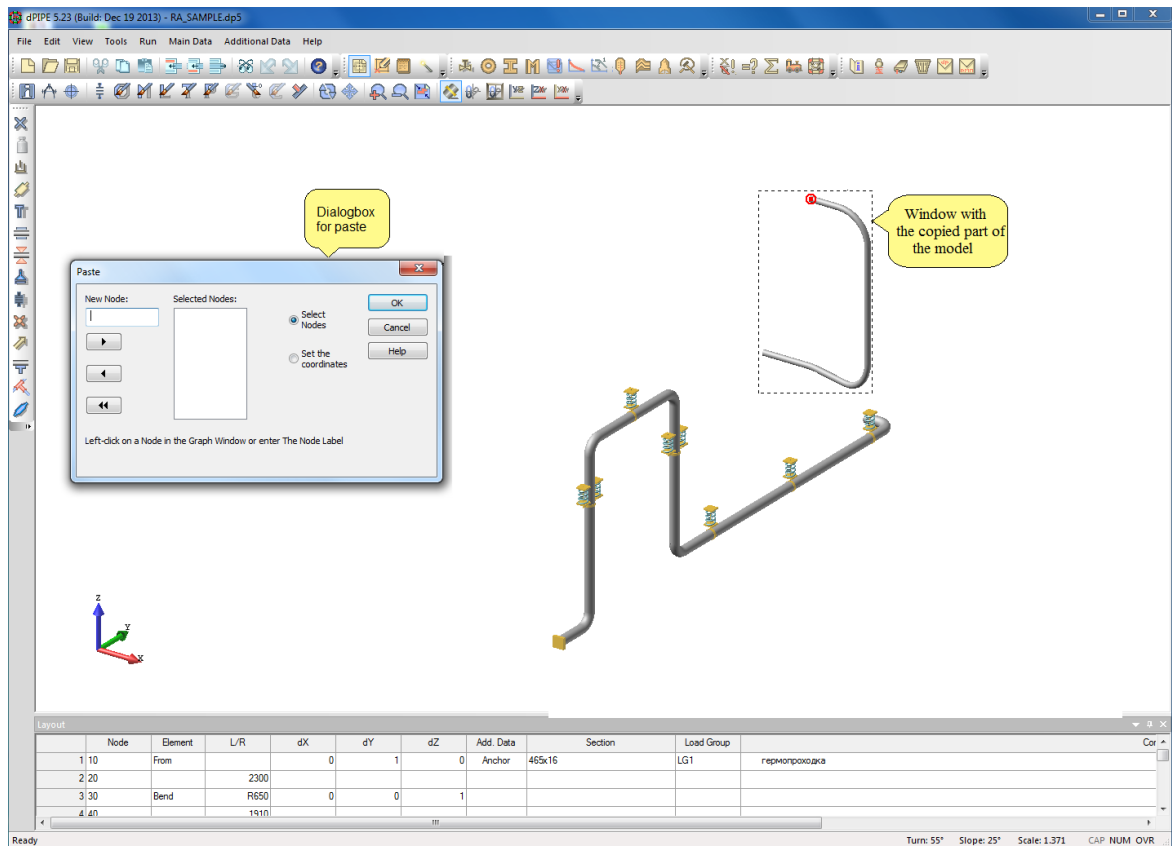

There are several methods for pasting the segment copied:

- paste the segment into the existing node (nodes) of the model; to do this it is necessary to perform left click on the required node or type the node label in the "New Node" field. In order to enter several nodes it is necessary to press and hold the **CTRL** key;
- paste the section using either the absolute coordinates for the base point or the coordinates with respect to the existing node of the model:

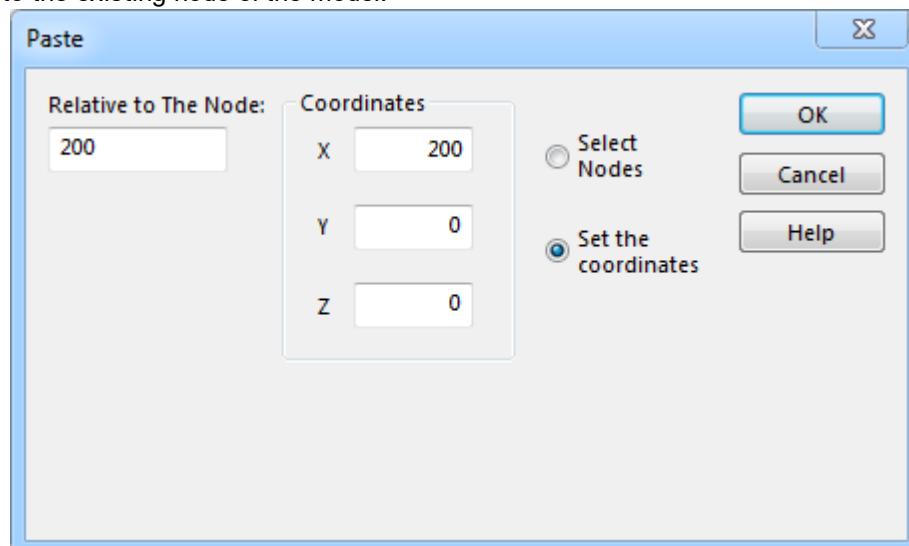

It should be noted that only those nodal additional data that are displayed at the moment of copying will fall into the segment copied. In doing so, the seismic groups of supports and the data related to the piping system operating modes (for example, pre-defined displacements of supports and concentrated loads) will not be copied.

## Changing the number display format



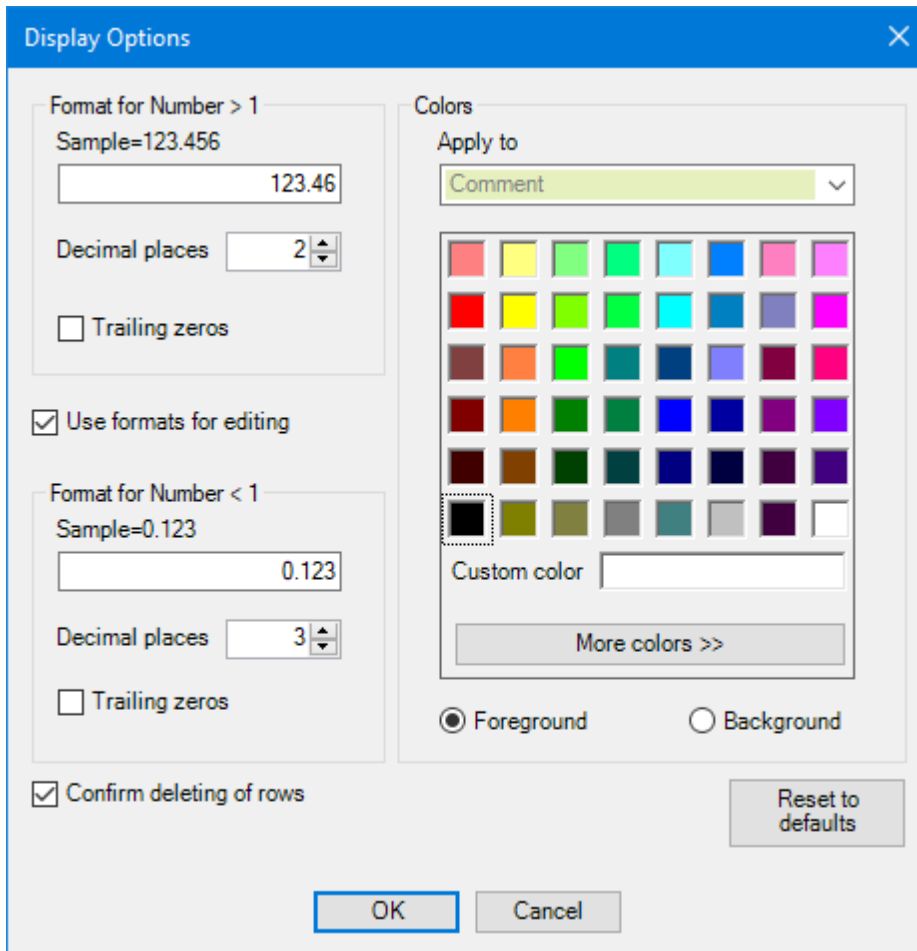

Option to change the format for displaying numbers in the tables and for data associated with nodes of the analysis model for which direction must be specified. The dialog is called from the "Layout" table by simultaneously pressing the CTRL key on the keyboard and the right mouse button. In the context menu that appears, select the "Additional" item. In the dialog that appears, you can configure the number format (number of digits after the decimal point):



## Toolbars

In order to provide easy operations with dPIPE, the [DDE](#) input data entry spreadsheet is equipped with the following set of toolbars, which can be customized by the User:

Toolbar	Display image
<a href="#">Main</a>	
<a href="#">Piping</a>	
<a href="#">Main data</a>	

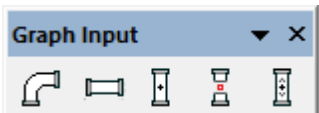
<a href="#">Analysis</a>	
<a href="#">Graphics</a>	
<a href="#">Additional Data</a>	
<a href="#">Utils</a>	
<a href="#">Graphic input</a>	

The toolbars (TB) allow hiding or showing individual buttons as required by the user. For example, it is possible to hide those button that are used rarely. For this purpose, it is necessary to do the following:

1. Make left click on the arrow to the right of TB:

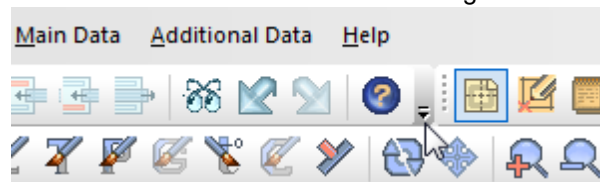

2. Place the mouse cursor over the "Add or Delete buttons" pop-down menu appeared. The menu with TB names will appear.
3. Place the cursor over the name of TB, which is to be changed, and, by right clicking on the button, mark (select) the buttons, which are to be displayed, or remove the marks (deselect) from the buttons, which are to be hidden:

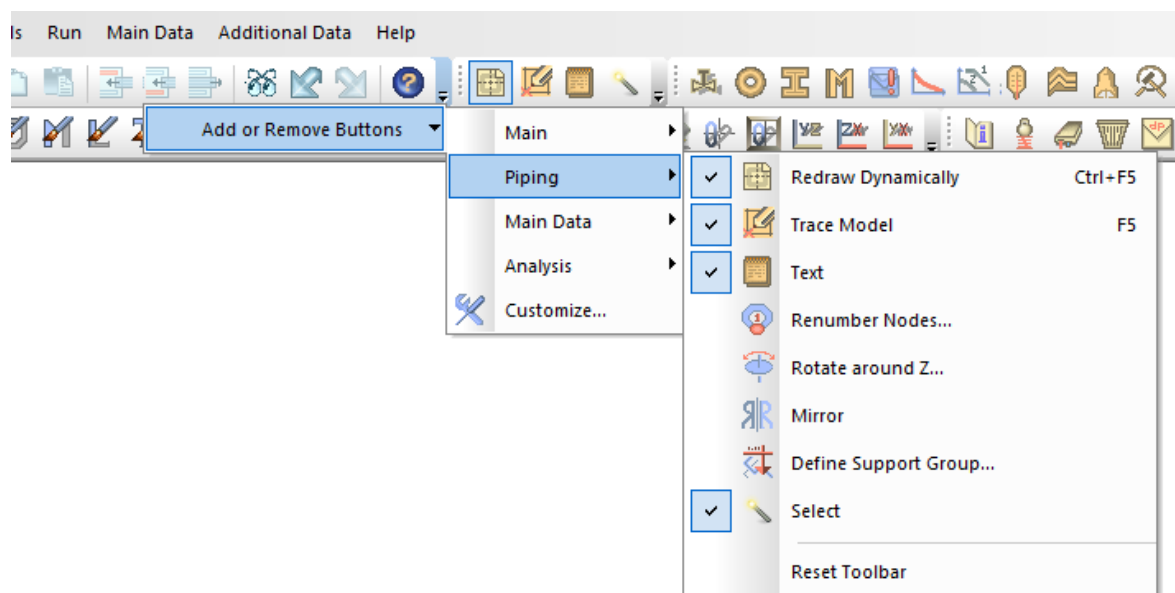





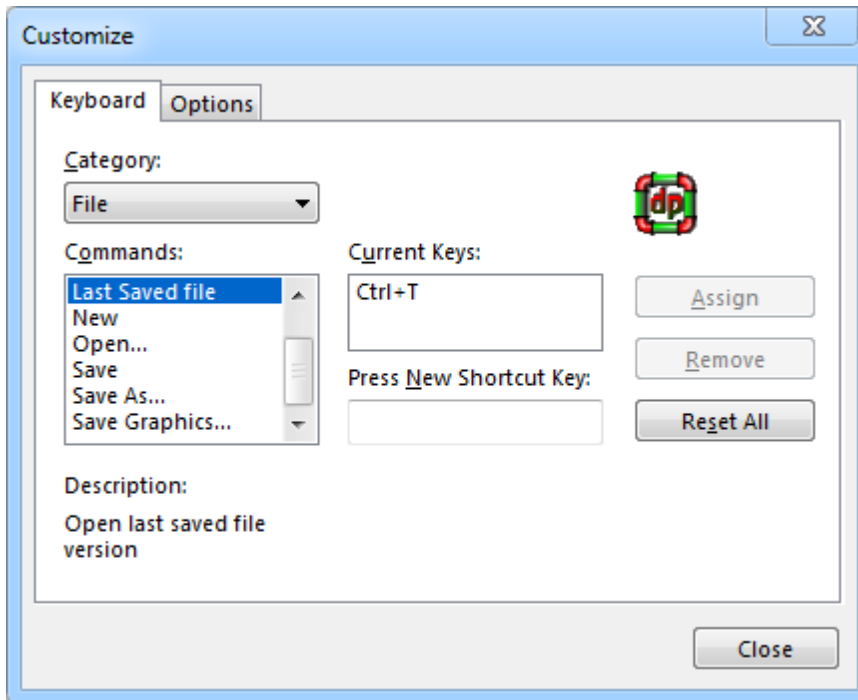



If on step 3 the «**Reset Toolbar**» menu item is selected, then a set of buttons defined for the TB by default will be displayed on it.







On step 2 the "Customize" menu item can be selected. (The same menu item is also contained in the "Tools" submenu of the program's main menu.) The following dialog box will appear:











The "Keyboard" tab of this dialog box allows to assign "hot keys". The "Options" tab allows selecting additional TB display options.

## Main toolbar



Button	Action	Hot keys
	Create a new model	CTRL+N
	Open a file with existing model	CTRL+O
	Save a model	CTRL+S
	"Cut" data (effective in the text window)	CTRL+X, SHFT+DEL
	"Copy" data (effective in the text window)	CTRL+C
	"Paste" data from the clipboard (effective in the text window)	CTRL+V
	Insert a new line under the current line (effective in the "Geometry" window)	CTRL+ENTER
	Insert a new line above the current line (effective in the "Geometry" window)	CTRL+SHFT+ENTER
	Delete a line (effective in all windows with spreadsheets)	CTRL+D









	Insert lines with <a href="#">comments</a> in the geometry spreadsheet	-
	Show/hide <a href="#">comments</a> in the geometry spreadsheet	-
	Find text content in the geometry spreadsheet	CTRL+ALT-F
	Find nodes and components ID in the graphic window	CTRL+F
	Cancel the previous action (effective only in the graphic window)	CTRL+X, ALT+Backspace
	Return to the previous action (effective only in the graphic window)	CTRL+Y
	Call "About program" information (also shows the licensing information and the number of connections for the network version of the program)	-

### "Piping" toolbar









Button	Action	Hot keys
	Enable/disable the dynamic mode of rendering	CTRL+F5
	Redraw the model once (tracing)	F5
	Enable/disable the text window with input data	F7
	Renum the nodes	-
	Turn the model at an arbitrary angle about the global Z axis	-
	Mirror the whole model	-
	Select and assign the support groups	-
	A tool for selecting a part of the model	-

### Spreadsheets with basic data



Button	Action	Hot keys
	Enable/disable the window with the piping system geometry spreadsheet	-
	Enable/disable the window with the valves spreadsheet	-
	Enable/disable the window with the pipe cross-section spreadsheet	-













	Enable/disable the window with the beam cross-section spreadsheet	-
	Enable/disable the window with materials spreadsheet	-
	Enable/disable the window with warnings	-
	Enable/disable the window with the fatigue strength spreadsheet	-
	Enable/disable the window with the specific data for high temperature piping	-
	Enable/disable the window with the piping system operation mode spreadsheet	-
	Enable/disable the window with seismic response spectrum spreadsheet	-
	Enable/disable the window with the specification for analysis and post-processing of the results	-
	Enable/disable the window with the analysis options	-

## Analysis











Button	Action	Hot keys
	Check of Input Data and launch of pre-processor	-
	Analysis	-
	Post-processing of the results	-
	Analysis in the batch mode	-
	Show the results in the graphic form (PIPE3DV)	-
	View the input data listing	-
	View the summarized tables with loads on supports	-
	View the results listing	-
	Clear the working folder	-







## Additional data

Button	Action
	Show/hide the anchor supports spreadsheet
	Show/hide the concentrated weight loads spreadsheet
	Show/hide the damper supports spreadsheet

	Show/hide the snubbers spreadsheet
	Show/hide the rod hangers spreadsheet
	Show/hide the guide supports spreadsheet
	Show/hide the restrains spreadsheet
	Show/hide the six-component supports spreadsheet
	Show/hide the spring support/hangers spreadsheet
	Show/hide the weld joints spreadsheet
	Show/hide the nodal force/moment spreadsheet
	Show/hide the sliding supports spreadsheet
	Show/hide the tee spreadsheet
	Show/hide the rigid struts spreadsheet
	Show/hide the spreadsheet with dynamic forces





### Operations with the graphic window

Button	Action	Hot keys
	<a href="#">Quick Information</a>	-
	<a href="#">measurement of distances between nodes</a>	-
	<a href="#">angle measurement</a>	-
	<a href="#">angle measurement(2)</a>	
	center the model in the window	CTRL+E
	call of " <a href="#">Display Options</a> " page	F3
	coloring of cross-sections	-
	coloring of materials	-
	coloring of load groups	-
	coloring of the temperatures for operational modes	-

	coloring of the pressures for operational modes	-
	coloring of the segment names	-
	coloring of the seismic support groups	-
	call of " <a href="#">Show elements by categories</a> " dialog	F4
	toggle into the model <a href="#">rotation</a> mode	-
	toggle into the model <a href="#">movement</a> mode	-
	<a href="#">zoom in</a> the model with respect of the mouse pointer	-
	<a href="#">zoom out</a> the model with respect of the mouse pointer	-
	show the entire model	CTRL+A
	enable/disable 3D view rendering	CTRL+F10
	toggle the model into isometry keeping an actual scale	CTRL+I
	toggle the model into isometry and show it on the whole	CTRL+SHFT-I
	show the model on the X axis side	CTRL+SHFT+Z
	show the model on the Y axis side	CTRL+SHFT+Y
	show the model on the Z axis side	CTRL+SHFT+X

Note: In the "coloring" mode, it is possible to change colors. To do this, double-click on the legend with the mouse

### Graphic input of the model

Button	Action	Samples
	Input of the straight piping section	<a href="#">Watch Video</a>
	Insert bends along branch	<a href="#">Watch Video</a>
	Insert intermediate node	<a href="#">Watch Video</a>
	Split branch	<a href="#">Watch Video</a>

	Move Node	<a href="#">Watch Video</a>
	Adding supports to the nodes of the model	<a href="#">Watch Video</a>

## Hot key summary

### General

Action	Key combination
Open a new file	Ctrl-N
Open a file	Ctrl-O
Save a file	Ctrl-S
Return to the file saved	Ctrl-T
Toggle between active windows	F6, Shft-F6

### Graphics window

Action	Key combination
Zoom	+/-
Rotate	→, ←, ↑, ↓
Move	Ctrl →, ←, ↑, ↓
Copy the graphic image of the model into the clipboard	Ctrl-C, Ctrl-Ins
Center the model in the window	Ctrl-E
Show the entire model	Ctrl-A
Show the model in isometry without zooming	Ctrl-I
Show the entire model in isometry	Ctrl-Shft-I
Show the entire model on the X axis side	Ctrl-Shft-X
Show the entire model on the Y axis side	Ctrl-Shft-Y
Show the entire model on the Z axis side	Ctrl-Shft-Z
Call a dialog for additional data	F3
Toggle between the graphics window and text window	F7
Return to the previous view	Backspace
Find a node	Ctrl-F
Search for text in the Spreadsheet or dp5 file	Ctrl-ALT-F
Show node labels	Shft-N
Show nodes	Shft-P

Show anchor supports	Shft-A
Show spring hangers/supports	Shft-H
Show stiff hangers	Shft-R
Show 6-component supports	Shft-S
Show nodal forces	Shft-F
Show sliding supports	Shft-I
Show guide supports	Shft-G
Show snubbers	Shft-U
Show restraints	Shft-J
Show dampers	Shft-D
Show weld joints	Shft-W
Show nodal weights	Shft-L
Show tees	Shft-T
Show dynamic stops with gaps	Shft-B
Show rigid struts	Shft-C
Show "anchors" for nodes with fixed coordinates	CTRL-ALT-Z
Enable/disable 3D rendering view	Ctrl-F10
Select elements by categories	F4
Show/hide elements selected by categories	Shft-F4
Zoom in/Zoom out proportionally the image of piping system diameters in the whole model	Ctrl - "Grey+" ("Grey-")
Return to unscaled diameter	Ctrl-1

#### Windows with Input Data entry spreadsheets

Action	Key combination
Edit a cell	F2
Move between adjacent cells	→, ←, ↑, ↓
Go to the next cell with data entry	Enter
Go to the 1st column	Home
Go to the last column	End
Paging	Page Up, Page Down
Go to the beginning of table	Ctrl-Home
Go to the end of table	Ctrl-End
Delete the current row of table	Ctrl-D
Insert a row before the current row	Ctrl-Shift-Enter

Insert a row after the current row	Ctrl-Enter
Find a Node	Ctrl-Alt-F
Trace the model	F5
Enable/disable dynamic tracing	Ctrl-F5
Open the window with node's properties	CTRL-ALT-Z

#### Main window in the text mode

Action	Key combination
Find a text	Ctrl-Alt-F
Find and replace a text	Ctrl-H
Copy a text into the clipboard	Ctrl-C
Paste a text from the clipboard	Ctrl-V

## Menu commands

[File menu](#)

[Edit menu](#)

[View menu](#)

[Tools menu](#)

[Analysis menu](#)

[Utilities menu](#)

[Main data](#)

[Additional data](#)

[Help menu](#)

## File

**File** – a conventional set of commands for operations with Input Data files (files with Input Data should have the extension \*.DP5). The commands allow creating a new model, open the current model, save the current model under another name, save the calculation model image as well as return to the last saved version of the file with Input Data.

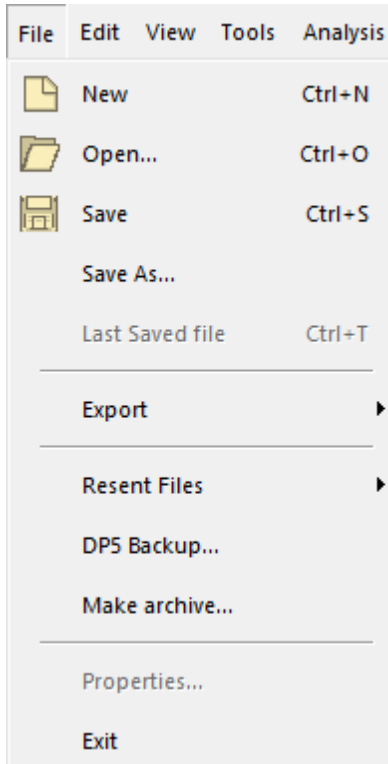

The “Export” command allows saving the image of the model into a file (Save Graphics), export a visible part of the model to [PCF format](#). The item “[Make Archive](#)” allows to create a ZIP archive of the project, the item “Properties” contains a link to the full path of the input data file \* .dp5.

See also [DP5 Backup](#)

### Create PCF

“Create PCF” allows converting the calculation model of the piping system into a file with the extension \*.PCF, which can be used for plotting isometric drawings of piping systems by means of software developed by [INTERGRAPH: ISOGEN SOLO EDITION](#) or [ISOGEN TEAM EDITION](#):

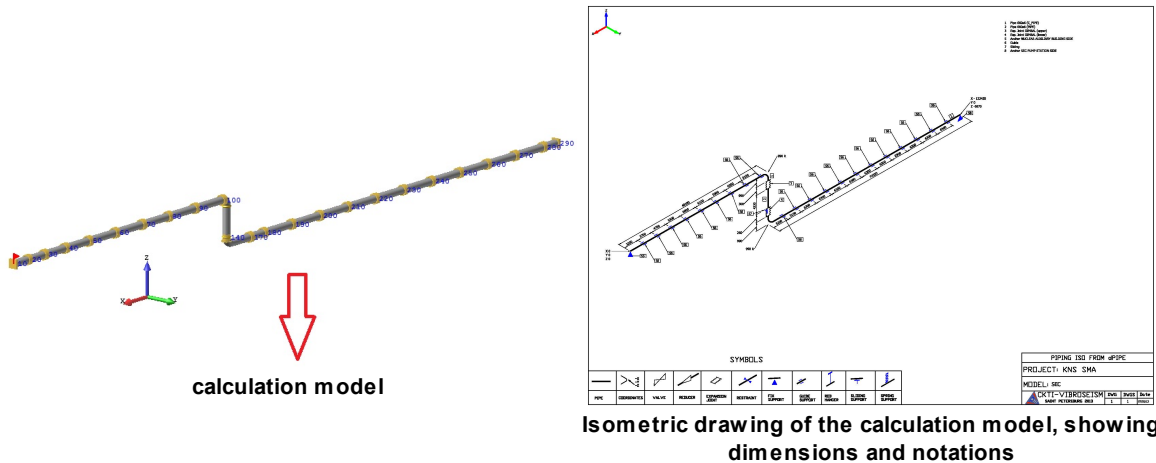

### Archive Project

The command allows creating a ZIP archive of the project, which includes a \*.dp5 file with input data, all relevant files referenced in the \*.dp5 file (spectra, accelerograms and files with dynamic forces are recorded in separate folders), the calculation results (files with \*.OUT, \*.SUP; \*.RES, \*.BIN), the file release\_info.txt with information about the current version of the program. Optionally, the archive includes a folder with databases. The archive file is named as <model name>\_YYYYMMDD.zip (year-month-day)

User can add user-defined rules for archiving files with arbitrary extensions. To do that one should record in the registry the key  
HKEY\_CURRENT\_USER\Software\CVS\dPIPE5.27\DDE\Options\ExtensionsToArchive:

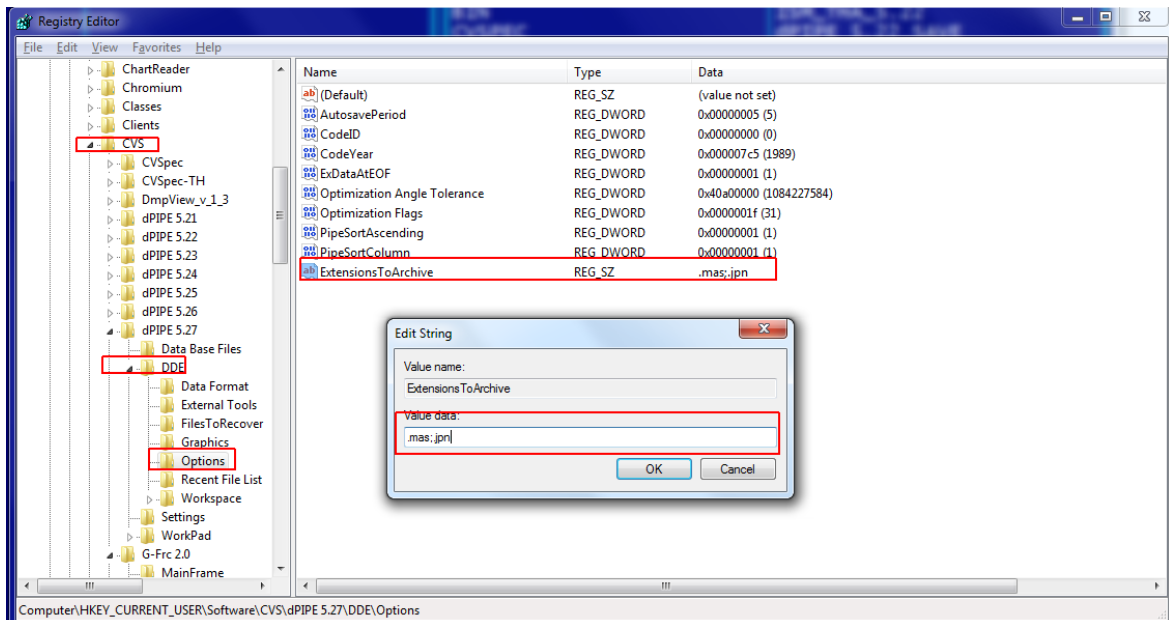

The key data ExtensionsToArchive is formed by the rule: .EXT, where EXT is the extension of the files to be added to the archive. When listing several types of extensions, a semicolon “;” is used as a separator.

**Warning: archiving option works only with the installed .NET Framework version 4.5 and higher**

## dP5 Backup

Depending on the "[Model Autosave Time](#)" parameter, dPIPE saves the calculation model every N minutes as specified in this parameter. Typically, in the event of a crash, the file with the calculation model automatically opens upon relaunching the program. If this does not occur, the User can use this command to open the folder where backup files are stored. Upon normal program termination, the backup file is deleted. Calculation model files saved in this folder are named using a code + the filename of the calculation model and the extension \*.dP5.

## Edit

**Edit** – a set of commands for Input Data editing. "**Find in Text**" and "**Find in Graphic**" commands let you search for node names, identification names of supports and piping elements, and other text information in various tables and in the graphic window of the program. The "**Insert/Delete row**" commands are active in the program dialogs containing spreadsheets with input data. The "**Modify**" command is active in the mode of selection of the elements (  button on the "[Piping](#)" toolbar)

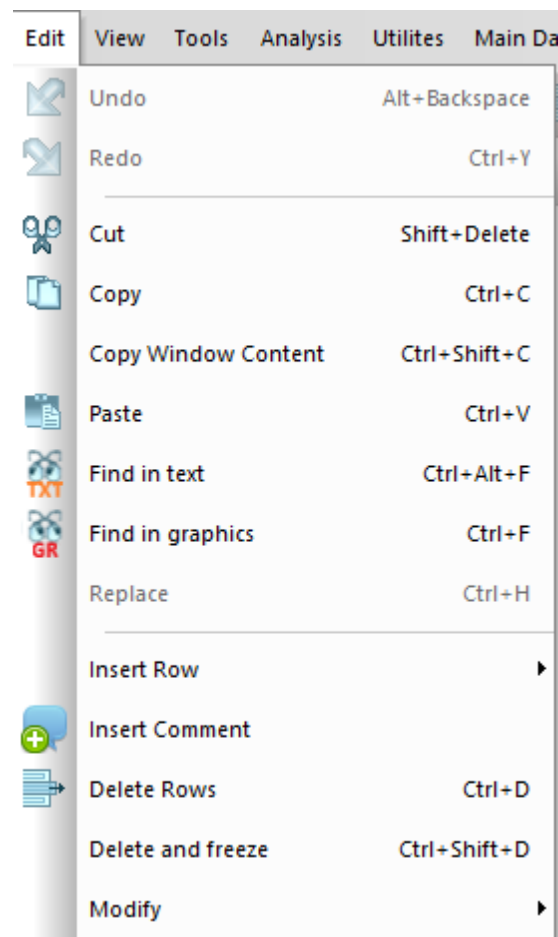

## View

**View** – a set of commands for activating certain elements of the spreadsheet interface. The "Text" command switched the program window into the graphic or text mode.

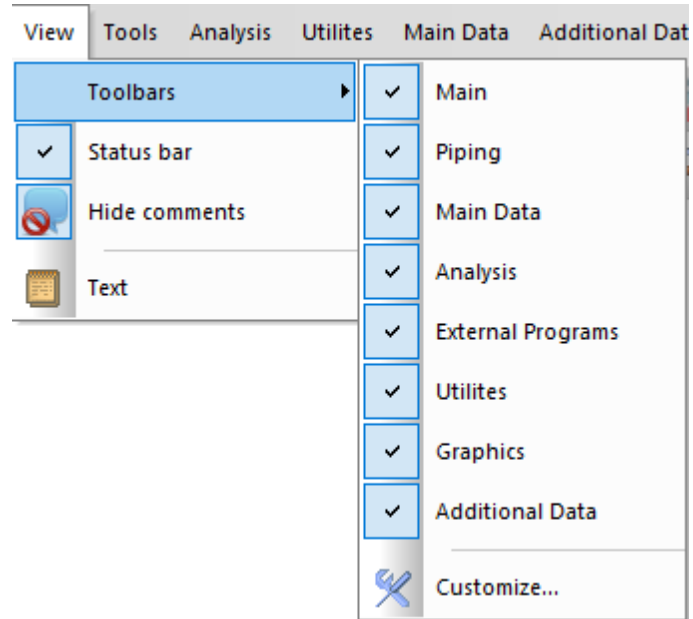

## Tools

**Tools** – a set of tools for work with [DDE](#).

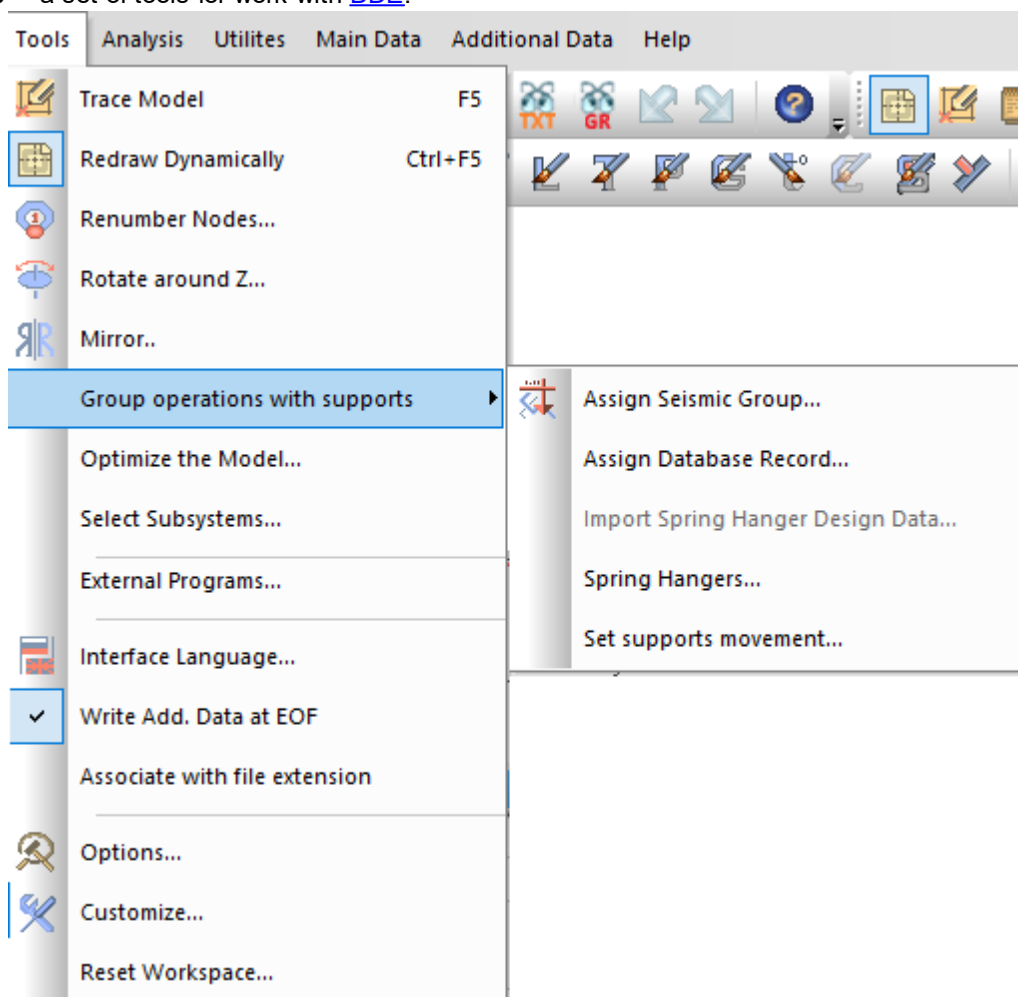

The "**Trace Model**" command performs a single check of the input syntax and redraw the piping system model without reaching the active mode.

In selecting the "**Redraw Dynamically**" mode, the Input Data entry is carried out in the active mode.

The "**Renumber nodes**" command allows renumbering the nodes of the current design mode according to the template specified:

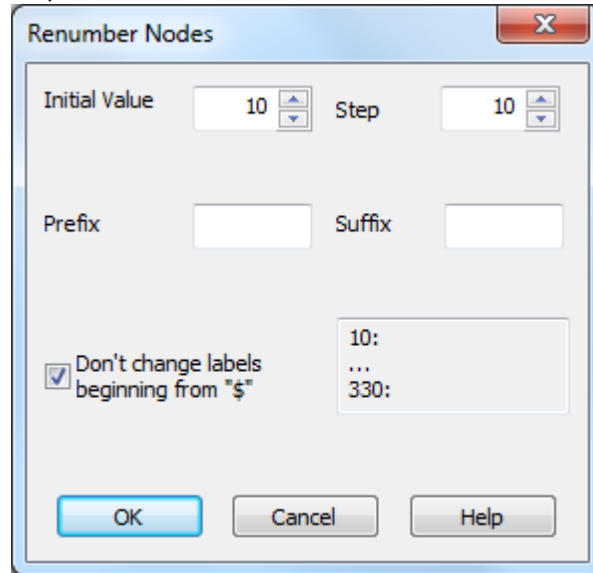

The "**Rotate around Z...**" command allows rotating the image of the whole model about the OZ axis at angle  $a$ . In doing so, the positive direction of the turn shall be counted from the OX axis to the OY axis:

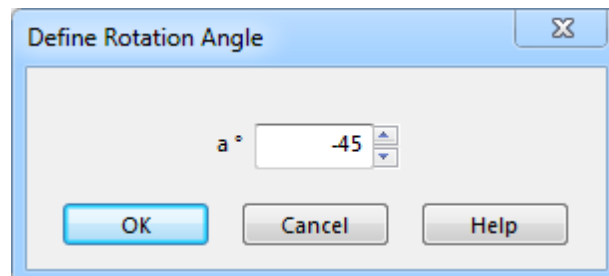

In case of model rotation, the automatic recalculation of the pre-defined displacements of supports takes place.

The "**Mirror...**" command allows mirroring the image of the whole model with respect to the XOZ or YOZ plane:

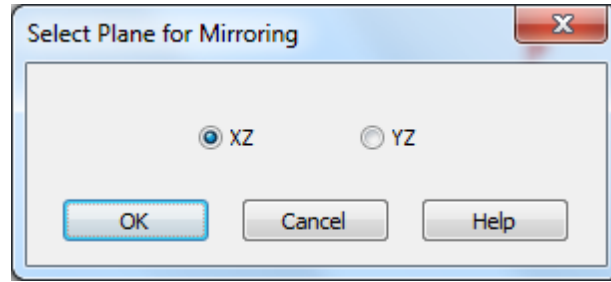

The command does not apply to the display of the cross sections of beam elements ( [Beam\(S\)](#) )

The command "[Group operations with supports](#)" contains a number of operations that are applied to various supports of the model selected with the mouse.

Upon the "**Optimize the model**" command, the model topology optimization (merge of individual branches) and the deletion of the intermediate nodes take place, which are not connected to any [additional data](#). The use of this command is convenient for models, which were created by converting data.

"**Select Subsystems**" command is used to define those portion of piping that may be marked as SBP (small bore pipes), see [Appendix XV](#). The RSBP value is the ratio of run to branch pipe moment of inertia

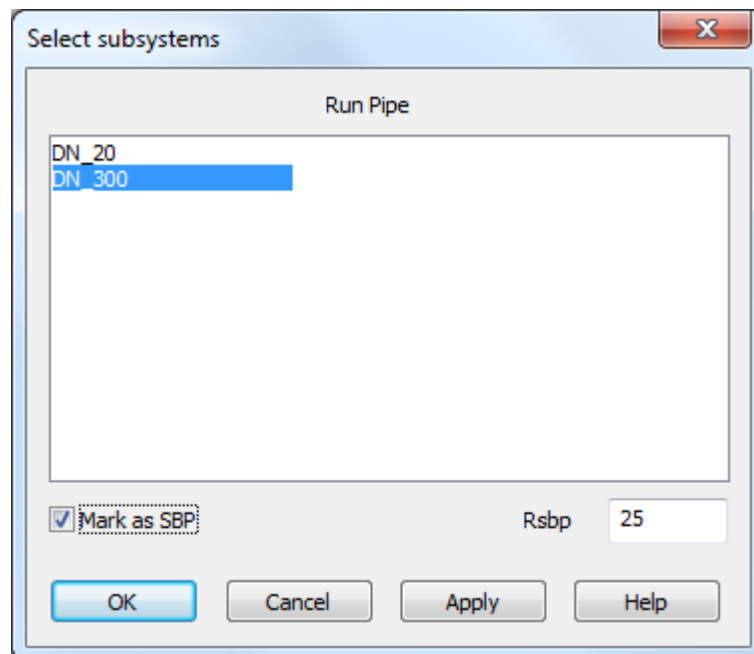



An option "**Write Add. Data at EOF**" allows put all the data associated with the nodes of the model (mainly this is piping supports) at the end of the \*.dp5 file, which allows them to be efficiently edited in the text mode

### Group operations with supports

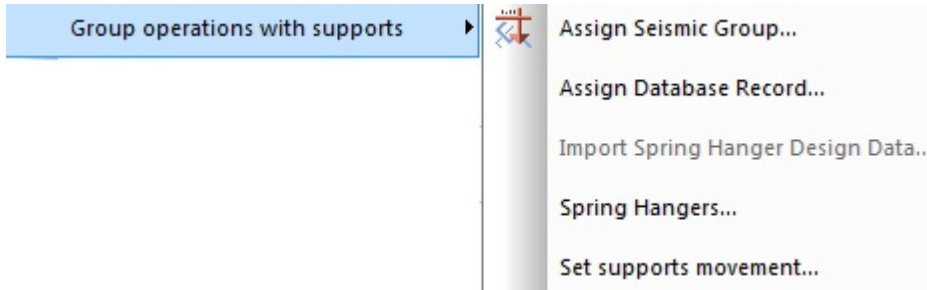
The set of the following commands is contained under the title "**Group operations with supports**":



The "**Assign Seismic Group**" command serves for assigning of the certain supports to specific seismic group associated with those defined in the "[Response spectra](#)" command. The command is used in seismic analysis by the [RSM](#) taking into account independent support motions (multi-support excitation effect). When the  button is pressed, the mouse cursor in the graphics window

takes the form of frame with arrow tool (  ) and the dialog appears displaying the groups assigned and allowing, in the graphics window, to mark those areas , in which the supports attributed to a certain seismic group are located:

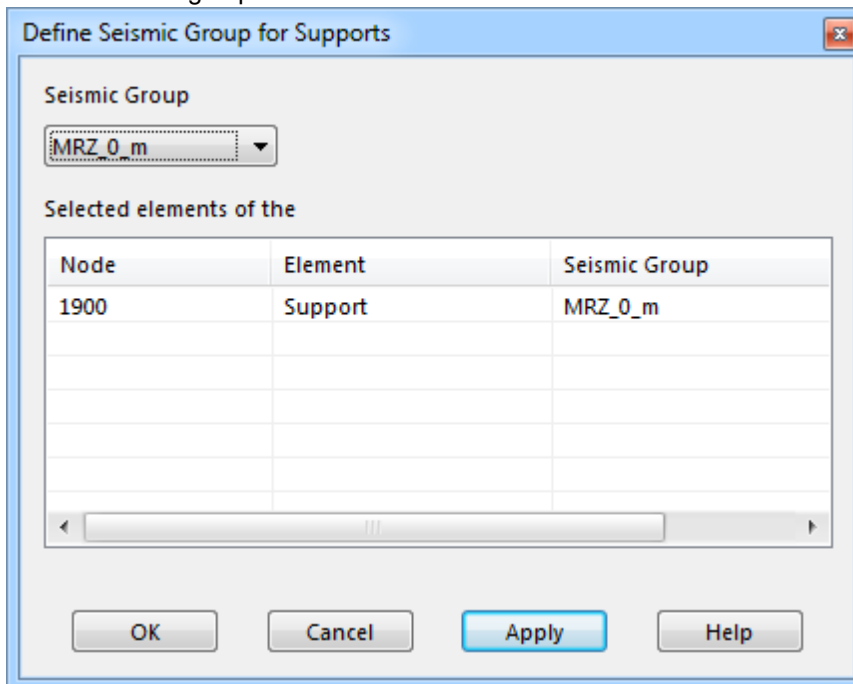

The "**Assign Database Record**" command allows selecting all one-type supports in the graphics window and assign them one and the same record from the [database](#) containing permissible loads on piping supports.

Watch Video

The "**Import Spring Hanger Design Data**" command allows the importing of the relevant data resulting from the calculations for spring's design (spring's types, sizes and operation load) to [DDE](#) table. This operation must be carried out immediately after the completion of the relevant calculations.

Watch Video

The "**Spring hangers...**" command is used for various operations under a selected group of the spring hangers/supports: change of the spring's size/type or table (catalogue), locking for hydraulic test, etc.

Watch Video

The "**Set supports movements**" command assigns predefined movements for the selected group of supports according to the operational mode consistent with this assignment.

Watch Video

### External programs

The "**External programs...**" command allows configuring the external modules, which could be connected and called from [DDE](#):

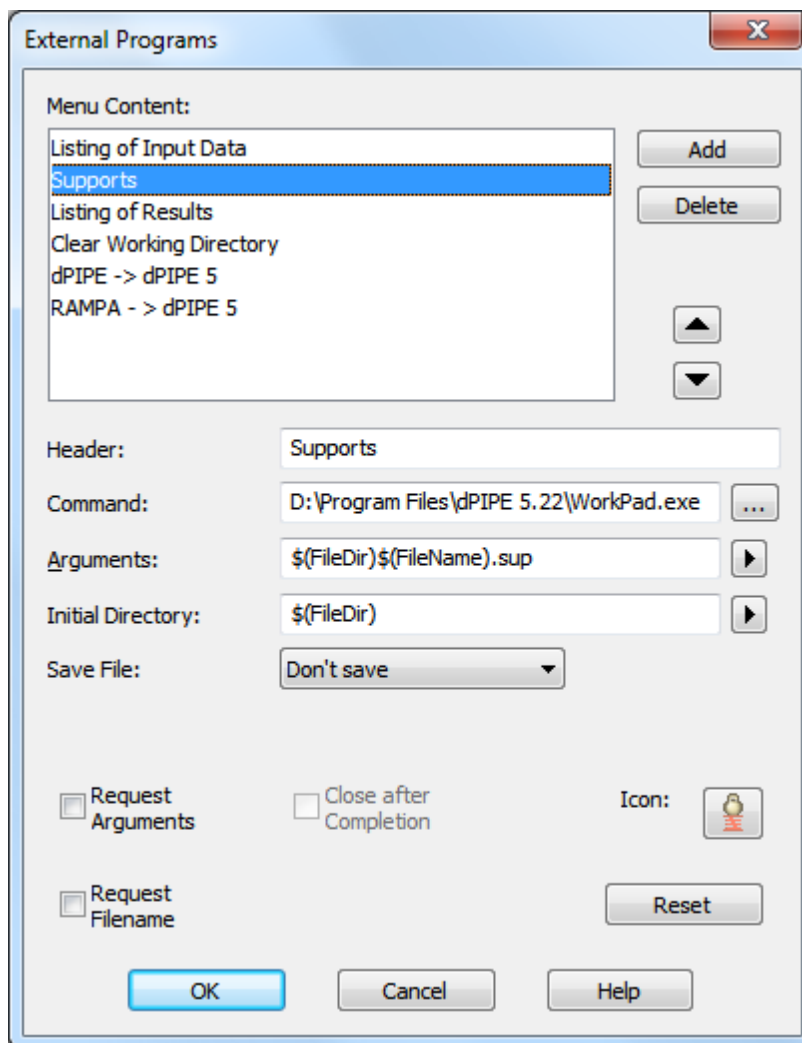

The dialog shown above allows to **add/delete** the programs connected, move them **up/down** in the "**Menu content**" field, give the title for executable programs (it is displayed both in the "**Tools**" menu and in pop-up tips to the corresponding buttons). The "**Command**" field contains the full part of the executable file, "**Arguments**" allow to transfer certain values to the command line:

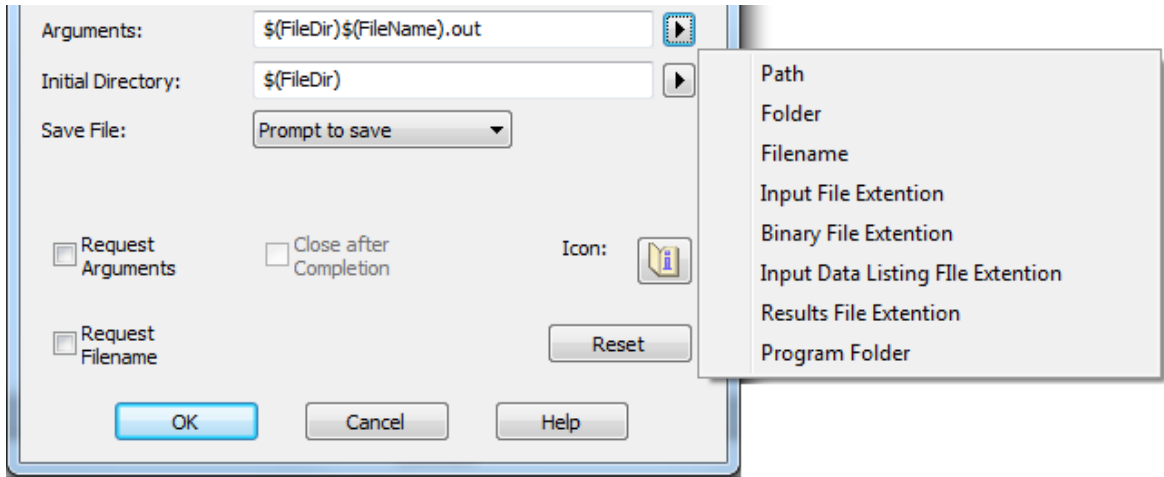

The **"Initial directory"** field specifies the place, from which a certain program shall be started:

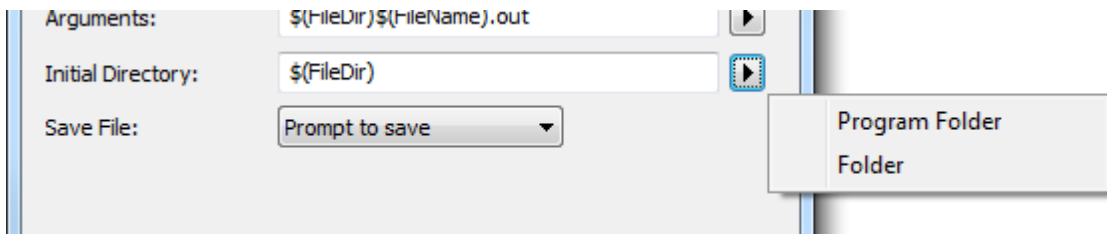

The **"Save a file"** option established the rules for saving the current Input Data file before execution of the external program.

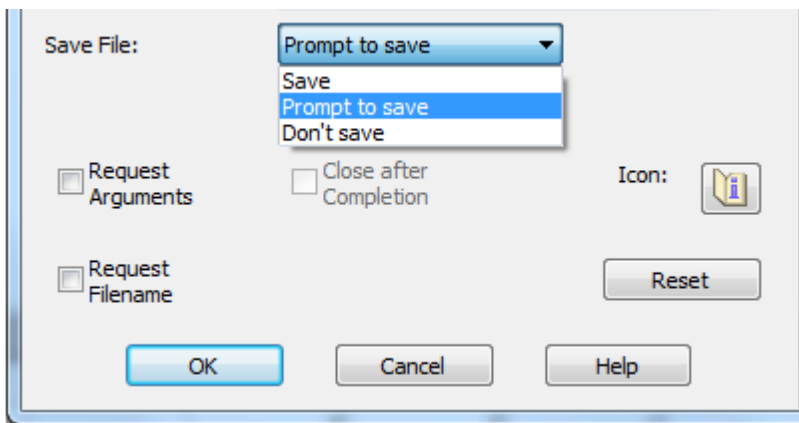

The **"Request the arguments"** , **"Close on completion"** and **"Request the filename"** fields can take the "Yes" and "No" values depending upon their activation by users.

The **"Image on the button"** field allows associating a certain picture on the button with the executable module:

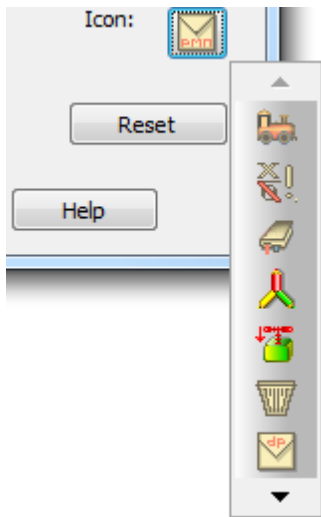

### Interface Language...

The **"Interface Language..."** command is used for changing the program interface language from Russian into English and vice versa. The change of language is carried out in the following dialog:

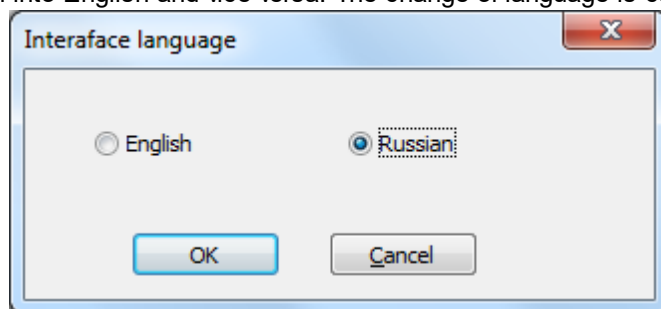

and shall be effective after restart of the [DDE](#) spreadsheet. With the change of language, not only the program interface but also the language of printouts of the input data and the results of analysis will change.

### Options and settings

The "Options" (  ) command allows to make settings of the connected database files, control parameters and specifications for analysis and post-processing of the results.

["Files"](#)

["Control parameters"](#)

["Specifications"](#)

["Reports"](#)

["Graphic Layout"](#)

The ["Settings"](#) command (  ) is used for establishing the user's set of toolbar "hot" keys and settings.

## Files

The **"Files"** folder allows to assign the location of files to be used at creating the calculation model of the piping system.

The following bookmarks are located inside the folder: **"DBS: Materials, Piping Elements, Spec"**

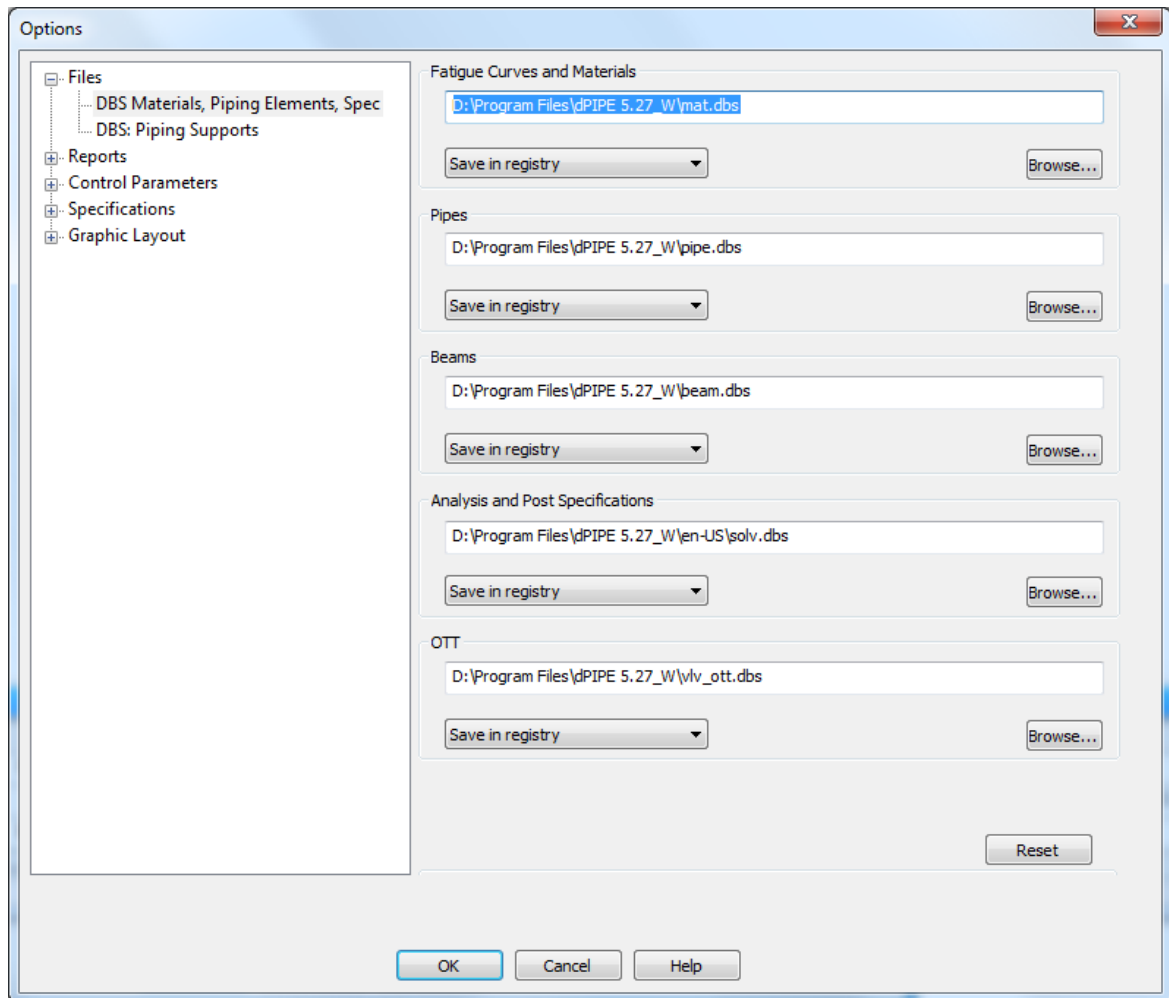

**"DBS: Piping supports":**

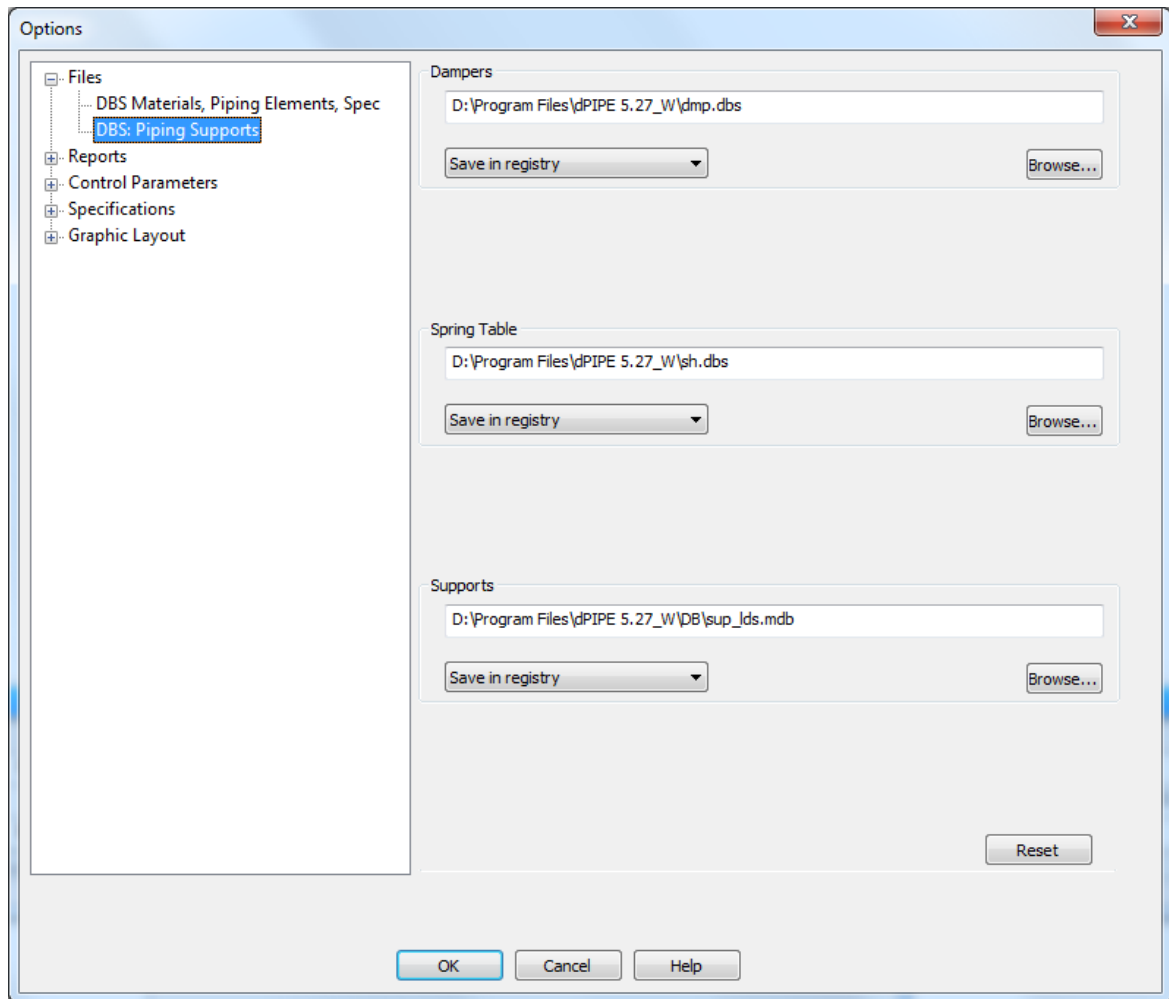

The tabs with databases contain paths to the corresponding files. Depending upon the options specified in the dialog these paths can be saved both in the system register ("save in registry") and can be written into a file with the model ("save in a file", see also the [DBF](#) command). With the "save relative paths" options being enabled, the program writes down the paths to files in respect to the folder, in which the model of the piping is located. This method is convenient for transferring the model from one computer to another.

The "Reset" button cancels all changes made by the User and returns all changes to the default parameters.

#### Reports

"Reports" tab determines the data to be used for generating of the summary tables with results ([POST\\_REP](#)):

Templates

### "Templates":

It defines location of templates that are used for output listing files with input data (\*.out) and results (\*.RES and \*.SUP). See command [DBF](#) as well.

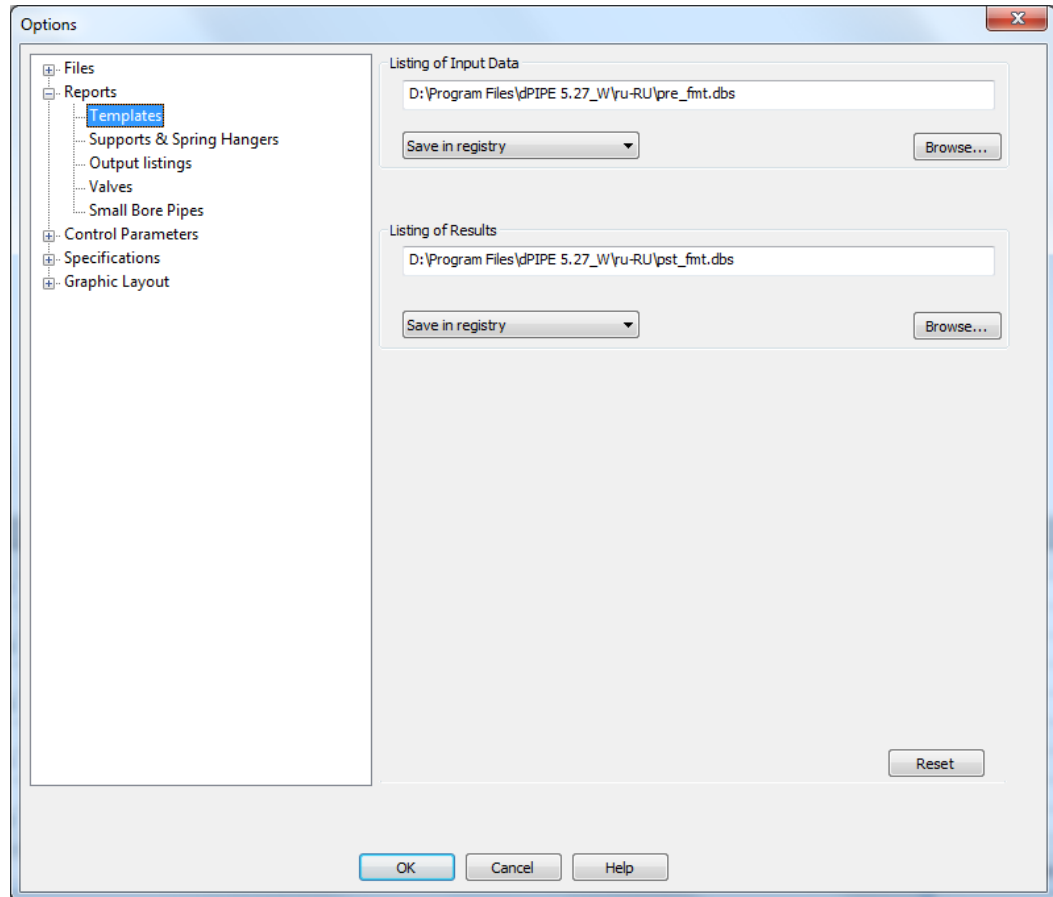

Supports & Spring Hangers

Dialog field	Parameter
Hot Load (hangers)	<a href="#">LOAD_HOT</a>
Cold load (hangers)	<a href="#">LOAD_CLD</a>
Design load (hangers)	<a href="#">LOAD_DES</a>
Hydrotest	<a href="#">LOAD_HT</a>
Seismic Load	LOAD_SEISM
Coordinate system for 6-component supports and Anchors	<a href="#">ANC_CS</a>
Coordinate system for Restraints	<a href="#">RSTR_CS</a>
Assessment of support's loads	<a href="#">SUP_LOADS</a>

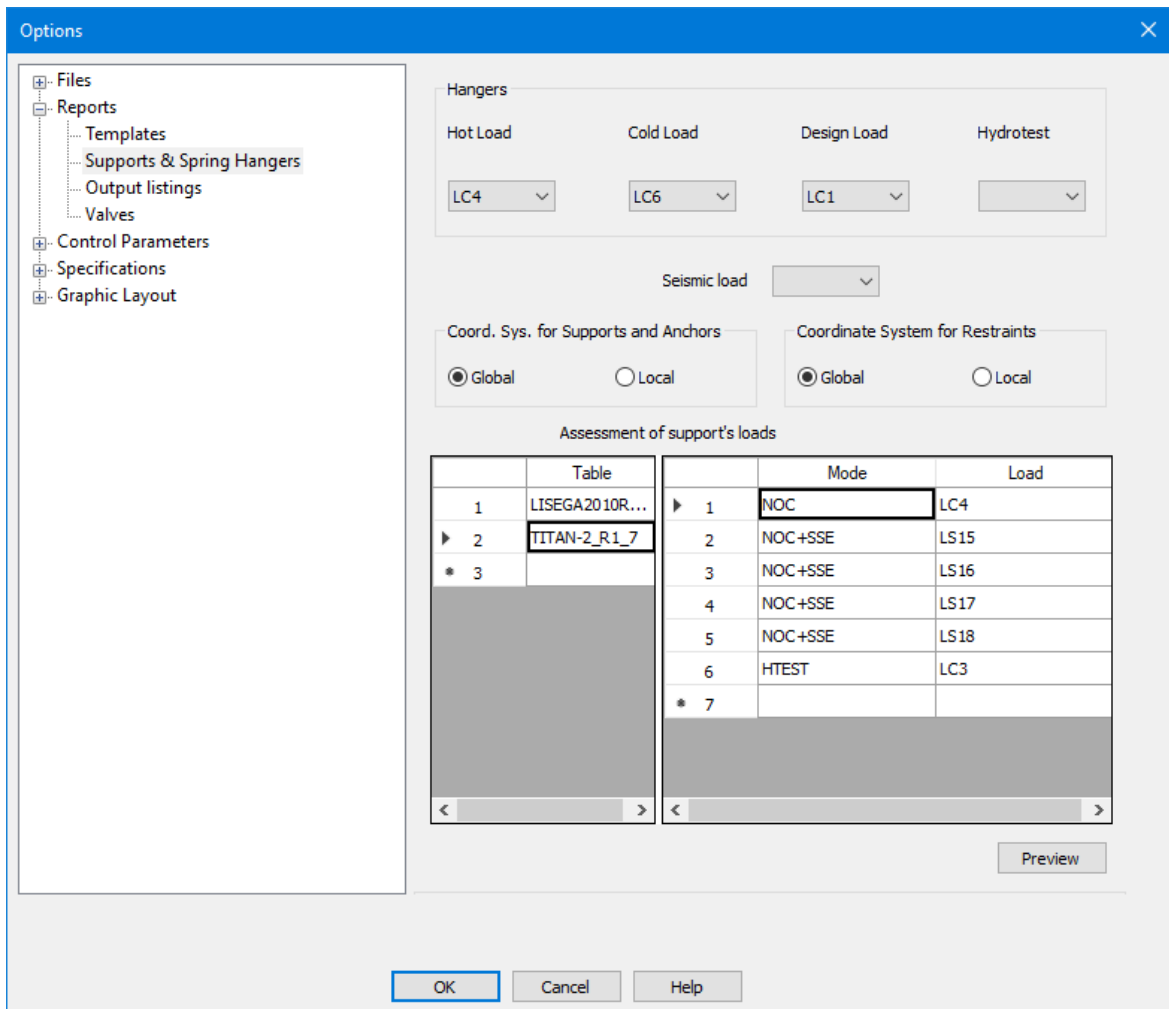

Output Listing

**"Output Listing":**

Dialog field	Parameter ( <a href="#">POST_REP</a> command)
Type of report	<a href="#">REP_TYPE</a>
Label to skip Supports from the Printout	<a href="#">SKIP_SUP</a>
Label to skip piping segment from the Printout	<a href="#">SKIP_STR</a>
Print Global Coordinates for Support's Locations	<a href="#">SUP_CRD</a>
Skip Printout for supports located at the marked piping segments (all Tables)	<a href="#">SUP_SKIP</a>
Remove Printout of piping segments marked as "skipped" from all tables	<a href="#">SKIP_OUT</a>

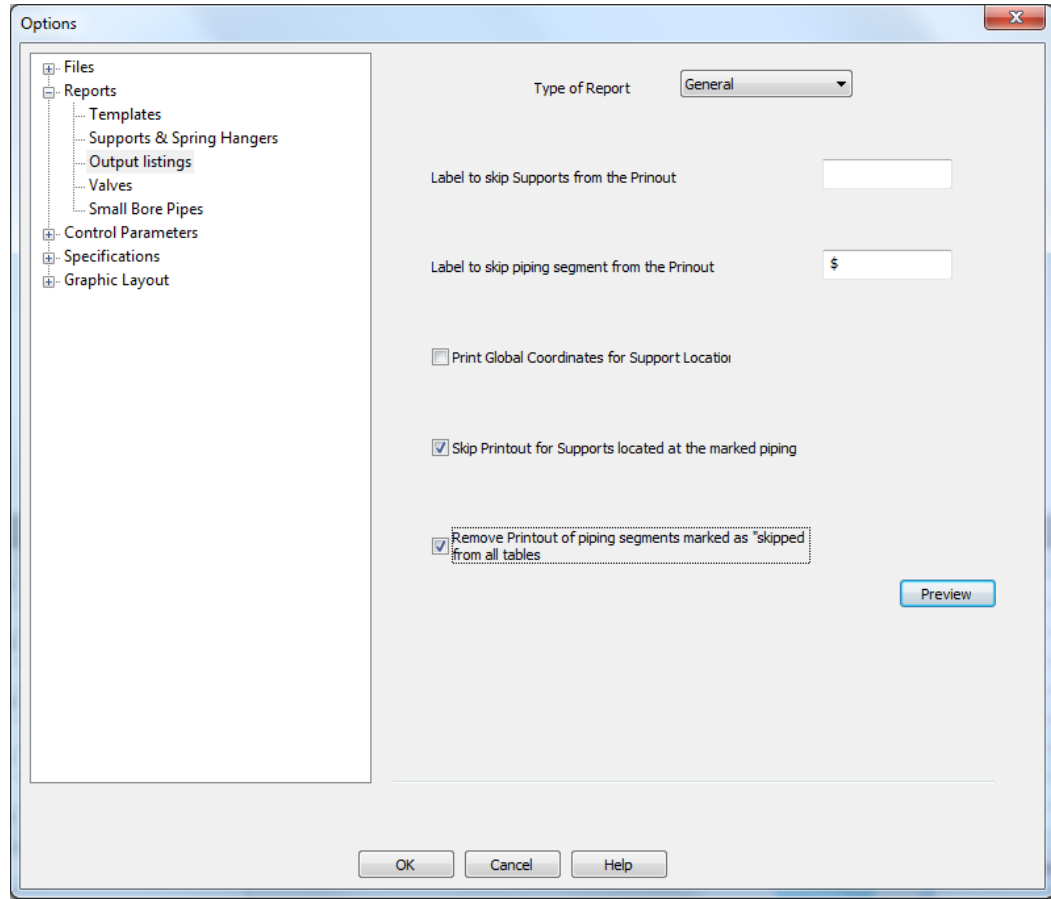

Valves

**"Valves":**

Dialog filed	Parameter ( <a href="#">POST_REP</a> command)
Weight load	<a href="#">OTT_W</a>
Thermal Expansion Load	<a href="#">OTT_I</a>
OBE Load	<a href="#">OTT_PZ</a>
SSE Load	<a href="#">OTT_MRZ</a>
Emergency Load	<a href="#">OTT_AS</a>

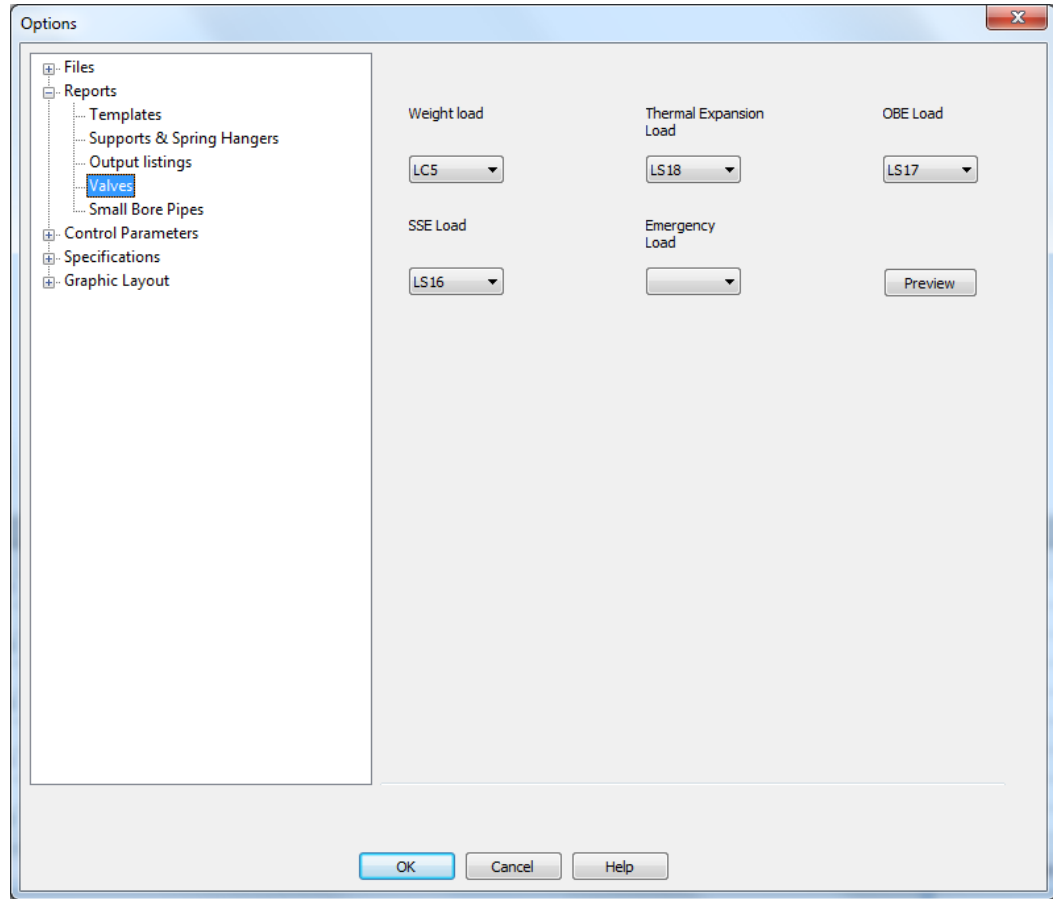

#### Small Bore Pipes

The tab “**Small-bore pipes**” becomes available for entering data when the model contains at least one segment of pipes marked as “**SBP**”, see [Appendix XV](#).

Dialog filed	Parameter ( <a href="#">POST_REP</a> command)
Reference on seismic stresses accounting the inertial loads for <b><i>small bore pipes</i></b>	<a href="#">IL_SBP</a>
Reference on seismic stresses accounting the inertial loads for <b><i>“big” bore pipes</i></b>	<a href="#">IL_LBP</a>
Reference on stresses accounting the secondary seismic (i.e. SAM) loads for <b><i>small bore pipes</i></b>	<a href="#">SL_SBP</a>

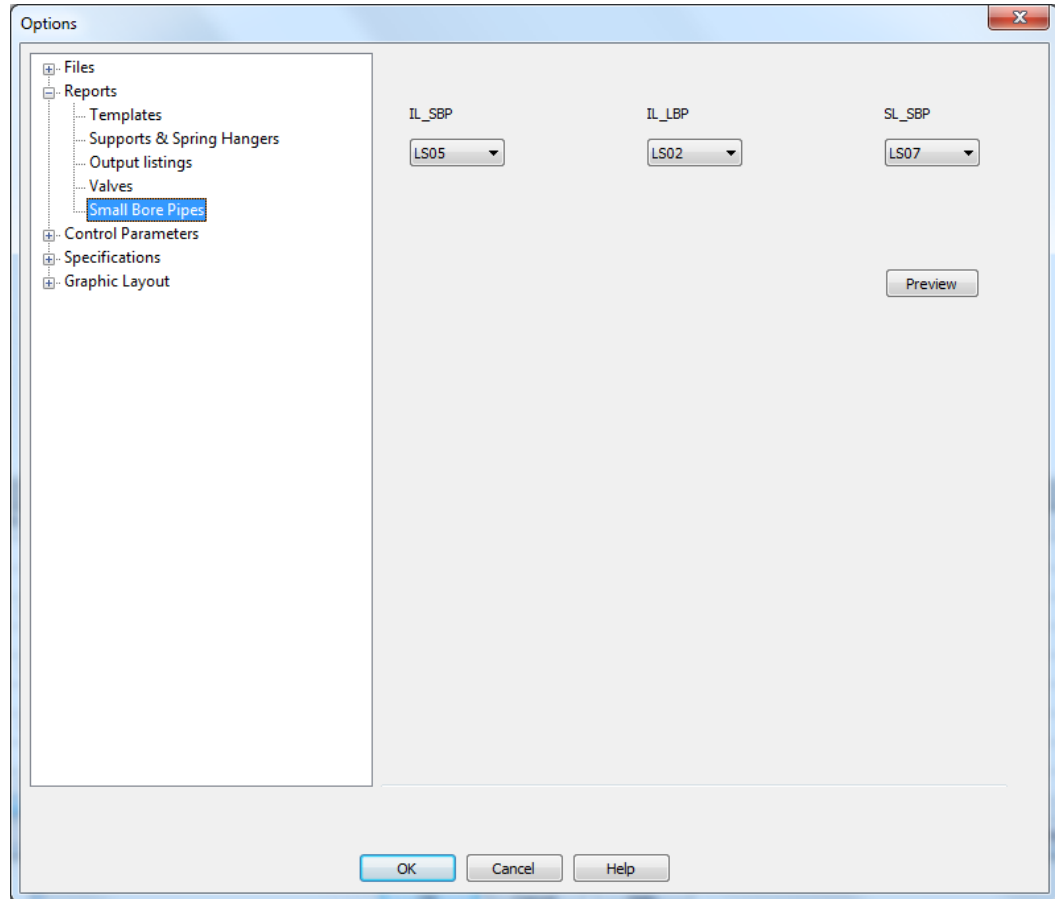

Control parameters

The **"Control parameters"** tab contains the parameters being described by the [CTRL](#) command and has four levels:

- ⇒ [Main](#) control parameters;
- ⇒ [Dynamic parameters](#);
- ⇒ parameters depending upon Strength analysis codes ([Code](#)) as well as
- ⇒ parameters for the springs of flexible hangers and supports of piping systems ([Hangers & Supports](#)).

Main parameters

### "Main" tab

Dialog field	Command	Parameter
Model Title	<a href="#">TITLE</a>	-
Ambient (Installation) temperature	<a href="#">CTRL</a>	<a href="#">TA</a>
Friction Scale	<a href="#">CTRL</a>	<a href="#">FRIC</a>
Minimal bend angle	<a href="#">CTRL</a>	<a href="#">BEND_ANG</a>
Minimal element length	<a href="#">CTRL</a>	<a href="#">EL_LEN</a>
Maximum number of iterations	<a href="#">CTRL</a>	<a href="#">NL_MAXIT</a>

Lift-off Criteria	<a href="#">CTRL</a>	<a href="#">LIFT</a>
Maximal mismatch value	<a href="#">CTRL</a>	<a href="#">MIS_MAX</a>
Transition Stiffness (default for "rigid")	<a href="#">CTRL</a>	<a href="#">RGD_TRN</a>
Rotational stiffness (default for "rigid")	<a href="#">CTRL</a>	<a href="#">RGD_ROT</a>
Model's autosave time	see: <a href="#">NOTE</a>	

Options

Model Title: **TITLE** Residual Heat Removing Piping

Ambient Temperature: **TA** 20

Friction Scale: **FRIC** 1

Minimal Bend Angle: **BEND\_ANG** 5

Minimal element length: **EL\_LEN** 1

Model autosave time in minutes: 5  
0 for disable autosave

Maximum Number of Iterations: **NL\_MAXIT** 99

Lift-off Criteria: **LIFT** 2

Transition Stiffness: **RGD\_TRN** 1e+009

Rotation Stiffness: **RGD\_ROT** 1e+014

Maximum misalignment:  Default **MIS\_MAX** 1

Reset

OK Cancel Help

**NOTE:**

The 'Model autosave time' feature is utilized by the program to periodically save the \*.dp5 file in a folder located at the address "%LocalAppData%/CVS/dPIPE 5.XX" (where XX represents the current version number of the program). In case of an abnormal termination of a session with DDE, the program attempts to recover data from this folder. Throughout the session, the program writes a \*.dp5 file to this folder under a name that includes the model's name:

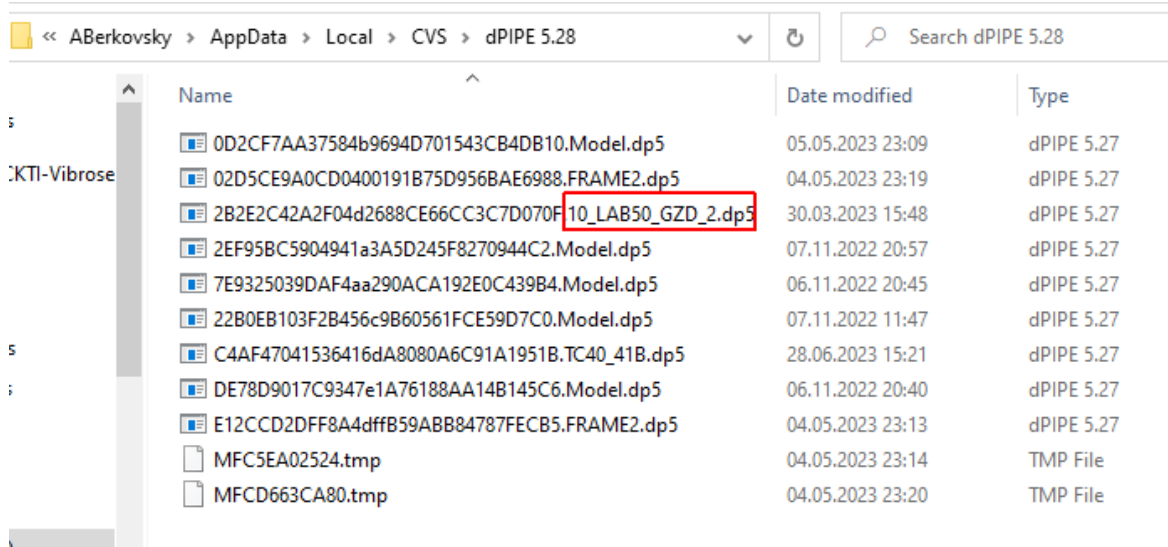

When the session terminates normally, the temporary file is deleted.

This folder can be accessed using the '[dP5 Backup](#)' command.

Dynamic parameters

## "Dynamic parameters"

Dialog field	Command	Parameter
Cut-off Frequency	<a href="#">CTRL</a>	<a href="#">FMAX</a>
Partial frequency for automatic meshing of the piping FE model (FMESH)	<a href="#">CTRL</a>	<a href="#">FMESH</a>
Zero period ground acceleration (ZPGA)	<a href="#">CTRL</a>	<a href="#">ZPGA</a>
Record Mode Shapes	<a href="#">CTRL</a>	<a href="#">FREQ_OUT</a>
Swing or pendulum effect for rod hangers	<a href="#">CTRL</a>	<a href="#">RH_PEND</a>

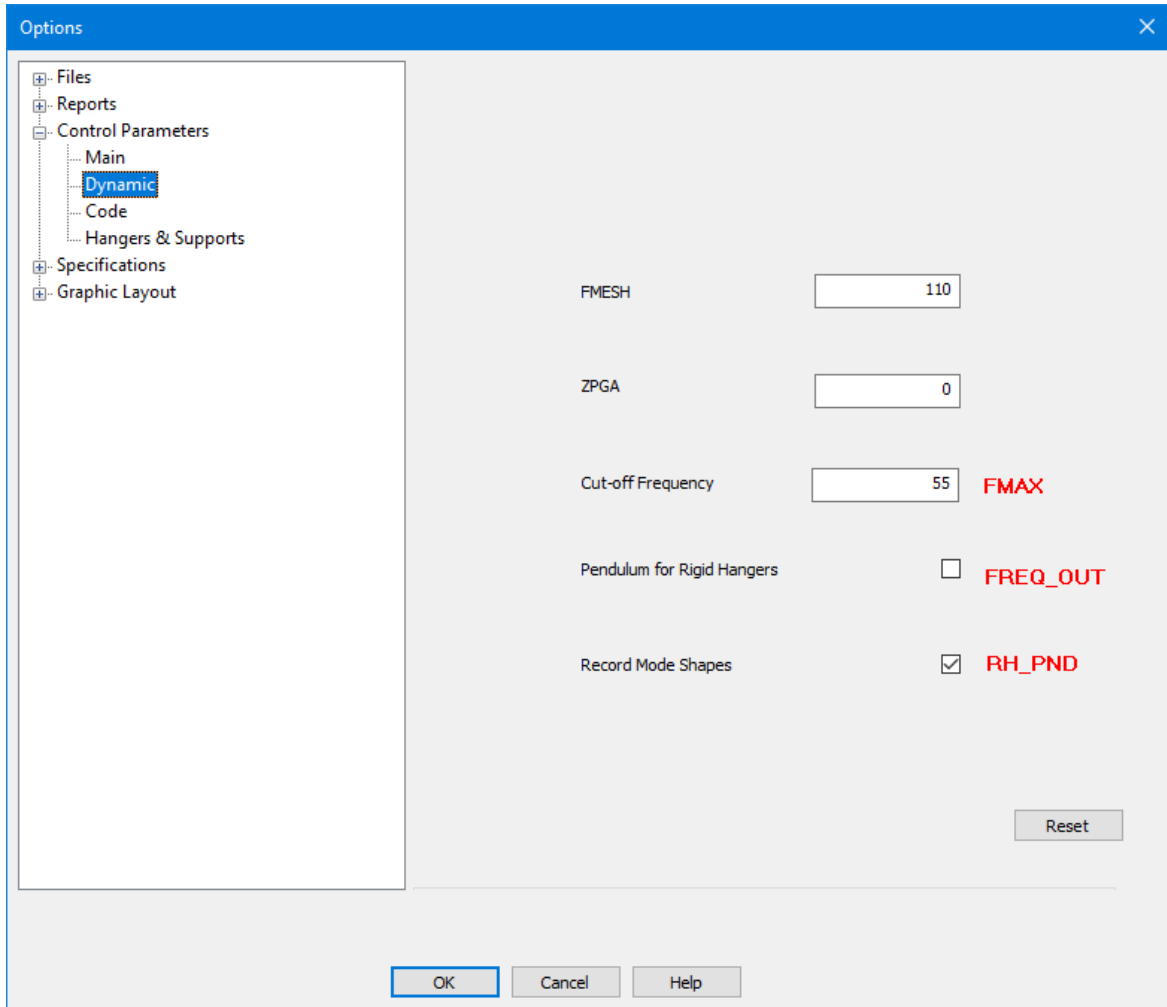

Code

## Strength Analysis Code

Dialog field	Command	Parameter
Codes	<a href="#">CTRL</a>	<a href="#">CODE</a>
Year	<a href="#">CTRL</a>	<a href="#">CODE_YEAR</a>
Out-of-Roundness options	<a href="#">CTRL</a>	<a href="#">OVAL</a>
Overload Factor	<a href="#">CTRL</a>	<a href="#">KS</a>
Check of all cross-sections with Welding Strength Reduction Factor	<a href="#">CTRL</a>	<a href="#">WLD_CHK</a>
Stress averaging factor (used for high temperature piping to address section's out-of roundness of the curved pipes)	<a href="#">CTRL</a>	<a href="#">HI_E</a>
Bend Flexibility Factor	<a href="#">CTRL</a>	<a href="#">BEND_CODE</a>
SN_T (criterion for the computation of allowable stresses for occasional and emergency loads)	<a href="#">CTRL</a>	<a href="#">SN_T</a>
Number of cycles	<a href="#">CTRL</a>	<a href="#">NC</a>

Option for accounting of the pressure for the bend flexibility factor	<a href="#">CTRL</a>	<a href="#">BEND_PRES</a>
Modulus of elasticity to be used for stiffness matrix generation (Hot or Cold)	<a href="#">CTRL</a>	<a href="#">E_MOD</a>
Simplified elastic-plastic analysis (for PNAE Code only)	<a href="#">CTRL</a>	<a href="#">PNAE_KE</a>
Occasional loads amplification factor for allowable stresses	<a href="#">CTRL</a>	<a href="#">K_OL</a>
Option for accounting the pressure for the bend stress index calculations (ASME B31.1 only)	<a href="#">CTRL</a>	<a href="#">BEND_PSTR</a>
Welding Stress Reduction Factor for Sustained Loads (ASME B31.1 only)	<a href="#">CTRL</a>	<a href="#">WLD_SUST</a>
Method for the computation of stresses from pressure at the SL category stress analysis	<a href="#">CTRL</a>	<a href="#">SL_PRES</a>
Method for the computation of SA permissible stresses for SE category stresses (ASME B31.1)	<a href="#">CTRL</a>	<a href="#">SA_LBRL</a>
Branch to Run Ratio (TEE assessment)	<a href="#">CTRL</a>	<a href="#">BRN_RUN</a>
Option for limitation of allowable stresses Sh and/or Sc with the value of 140 MPa	<a href="#">CTRL</a>	<a href="#">SH_140</a>
Option to account the weld strength factor for stresses at stage IV (RD Code)	<a href="#">CTRL</a>	<a href="#">RD_WLD_IV</a>
Use CKTI Engineering methodology for Stress Analysis of Tees and Branch Connections (only within 'RD' Code), See <a href="#">Appendix XIII</a> .	<a href="#">CTRL</a>	<a href="#">TEE_RD</a>
Option for tee/branch connections flexibility factors. Applicable for "standard" tees. See <a href="#">Appendix XIV</a> .	<a href="#">CTRL</a>	<a href="#">TEE_FLEX</a>

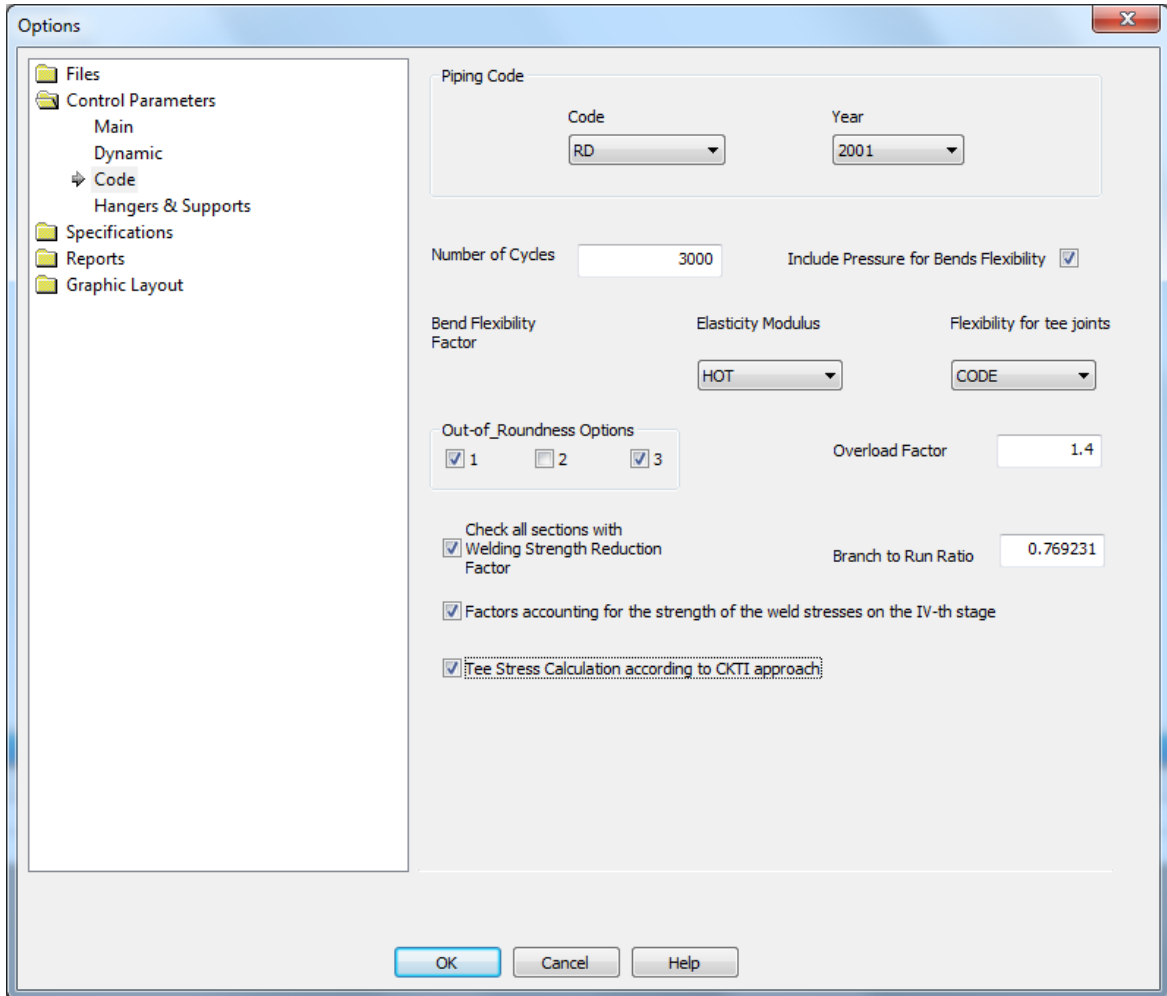

Hangers and Supports

### Hangers and Supports

Dialog field	Command	Parameter
Spring's Table (Standard)	<a href="#">SDEF</a>	<a href="#">STAB</a>
Load Variability	<a href="#">SDEF</a>	<a href="#">PVAR</a>
Load Capacity Factor	<a href="#">SDEF</a>	<a href="#">PFAC</a>
Max. Chain Number	<a href="#">SDEF</a>	<a href="#">ZMAX</a>
Min. Chain Number	<a href="#">SDEF</a>	<a href="#">ZMIN</a>
Stiffness used for spring's design (stiffness of the "rigid" support when spring size is selected to balance weight load)	<a href="#">CTRL</a>	<a href="#">RGD_SPR</a>
SPR_SFPMIN ( <i>minimum load safety margin coefficient</i> )	<a href="#">CTRL</a>	<a href="#">SPR_SFPMIN</a>
SPR_VARTOL ( <i>reference variability value to be used in selecting the springs</i> )	<a href="#">CTRL</a>	<a href="#">SPR_VARTOL</a>
SPR_TRTRAV ( <i>method to compute spring travel</i> )	<a href="#">CTRL</a>	<a href="#">SPR_TRTRAV</a>
Stiffness of rod hangers and locked spring hangers	<a href="#">CTRL</a>	<a href="#">RH_STE</a>
<b>Swing (Pendulum) Effect</b>		

Spring hangers	<a href="#">CTRL</a>	<a href="#">SWING_SH</a>
Stiff hangers	<a href="#">CTRL</a>	<a href="#">SWING_RH</a>
Stiff tie rods	<a href="#">CTRL</a>	<a href="#">SWING_ST</a>

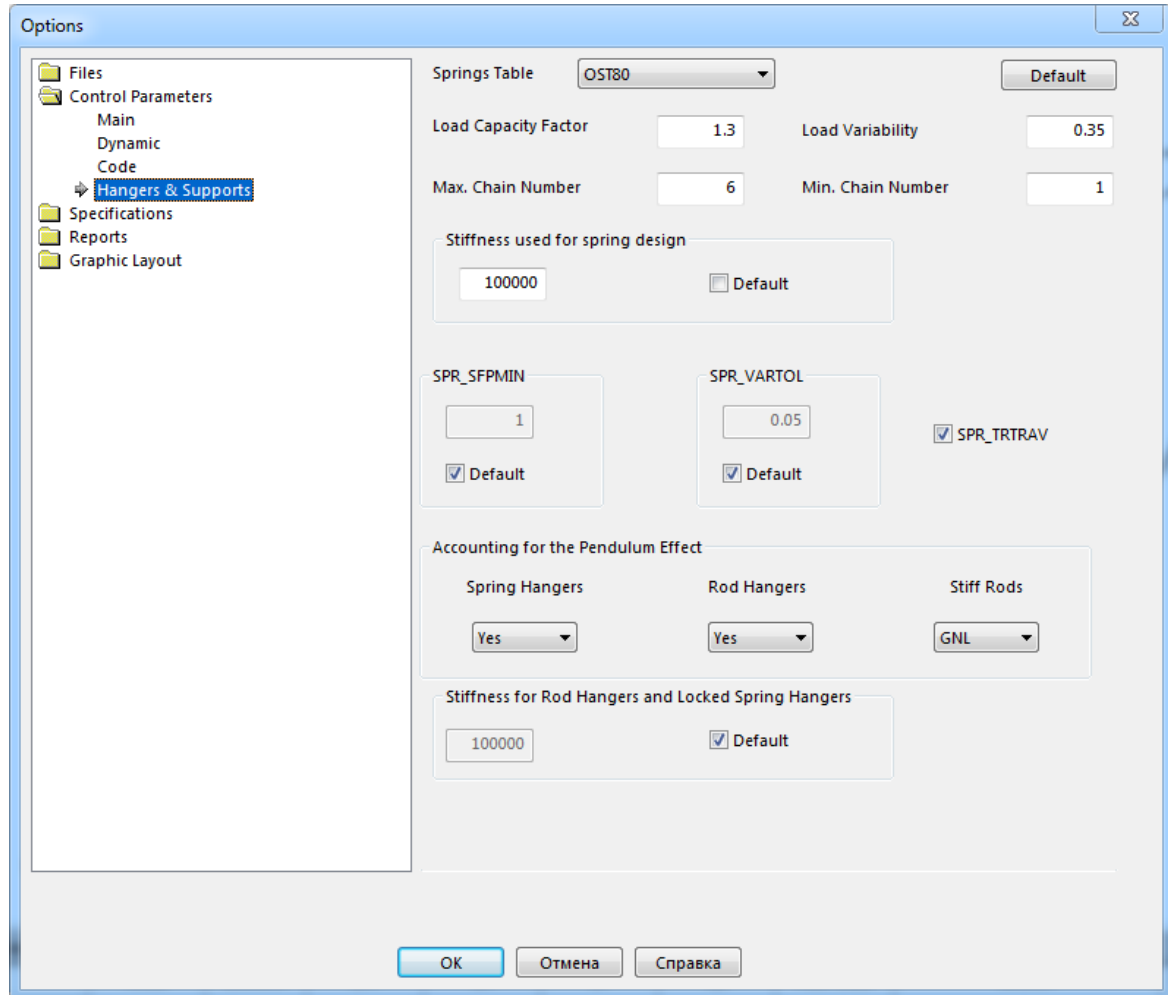

#### Specifications

This tab defines data required for FATIGUE analysis ("Fatigue analysis", [FATG](#) command) and High Energy Lines Break (HELB) analysis ([POST\\_HELB](#) command).

#### Fatigue Analysis

#### "Fatigue Analysis":

Dialog field	Command	Parameter
Load Cases/Load Sets	<a href="#">SOLV</a>	<a href="#">LC</a>
Number of cycles	<a href="#">FATG</a>	<a href="#">NC</a>
Loading history	<a href="#">FATG</a>	<a href="#">SEQ</a>
Simplified analysis	<a href="#">FATG</a>	<a href="#">FATG_SAE</a>
Option for the Range of Mechanical Loads	<a href="#">FATG</a>	M_RANGE

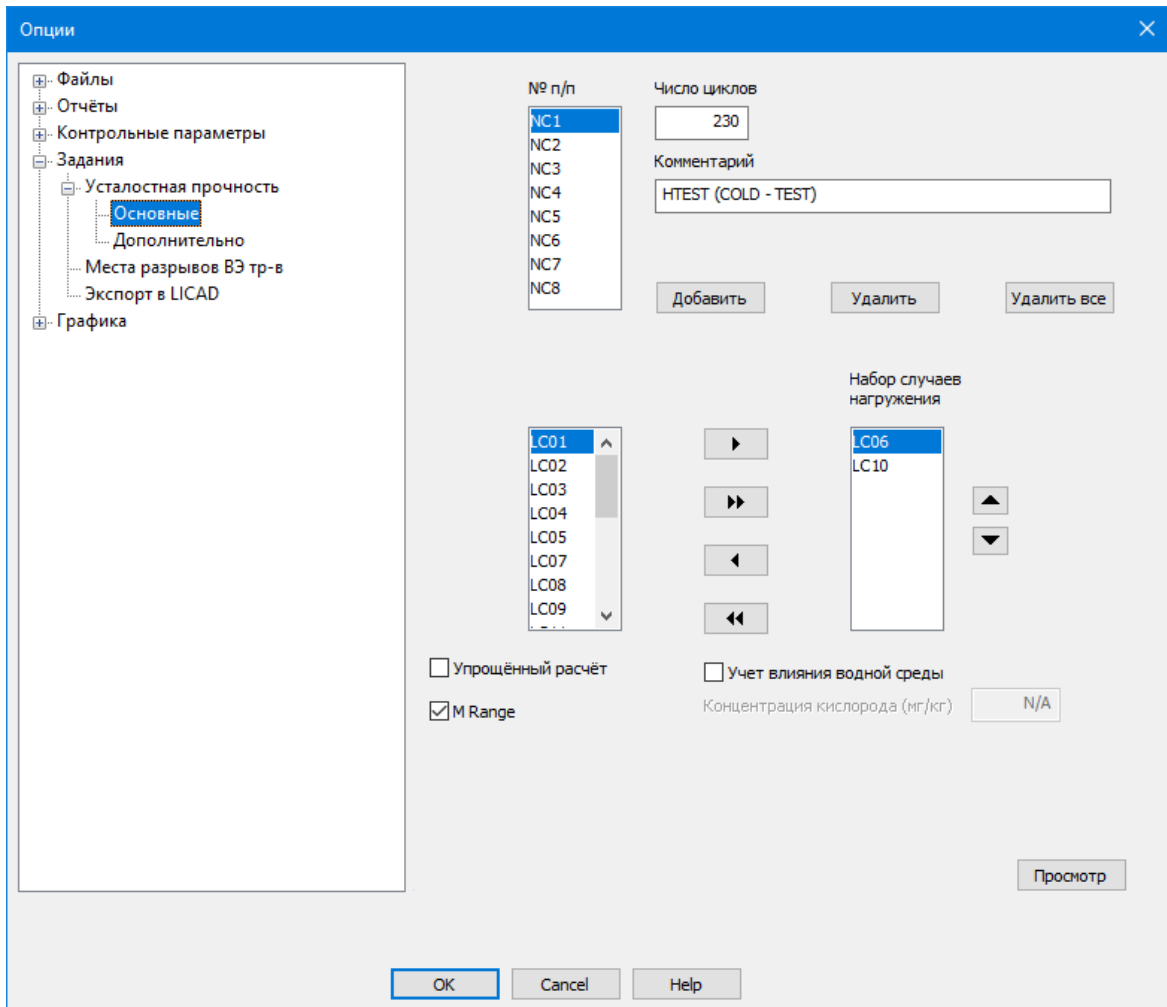

**Additional data for fatigue strength analysis:**

Dialog field	Command	Parameter
LC	<a href="#">FATG</a>	<a href="#">LOAD</a>
TEMP	<a href="#">FATG</a>	<a href="#">TEMP</a>
MECH	<a href="#">FATG</a>	<a href="#">MECH</a>

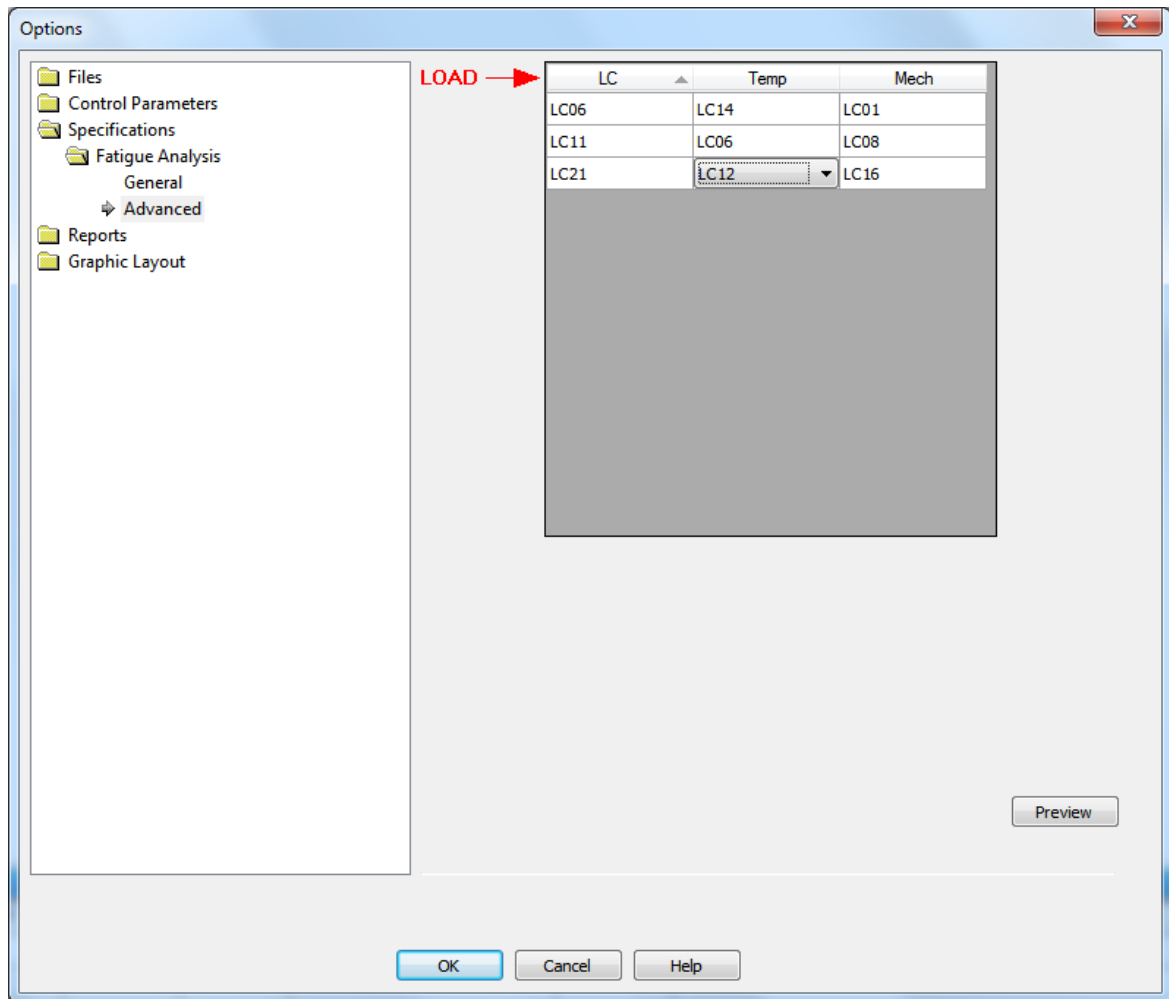

HELB

**HELB** tab specifies data for High Energy Line Breaks (HELB) analysis to define postulated ruptures and through-wall cracks.

Dialog field	Command	Parameter
CUF	<a href="#">POST_HELB</a>	<a href="#">CUF</a>
RUPTURE	<a href="#">POST_HELB</a>	<a href="#">RUPTURE</a>
CRACK	<a href="#">POST_HELB</a>	<a href="#">CRACK</a>
MECH	<a href="#">POST_HELB</a>	<a href="#">MECH_LS</a>
RANGE	<a href="#">POST_HELB</a>	<a href="#">RANGE_LS</a>
Prefix	<a href="#">POST_HELB</a>	<a href="#">HELB_STR</a>
Document	<a href="#">POST_HELB</a>	<a href="#">DOC</a>

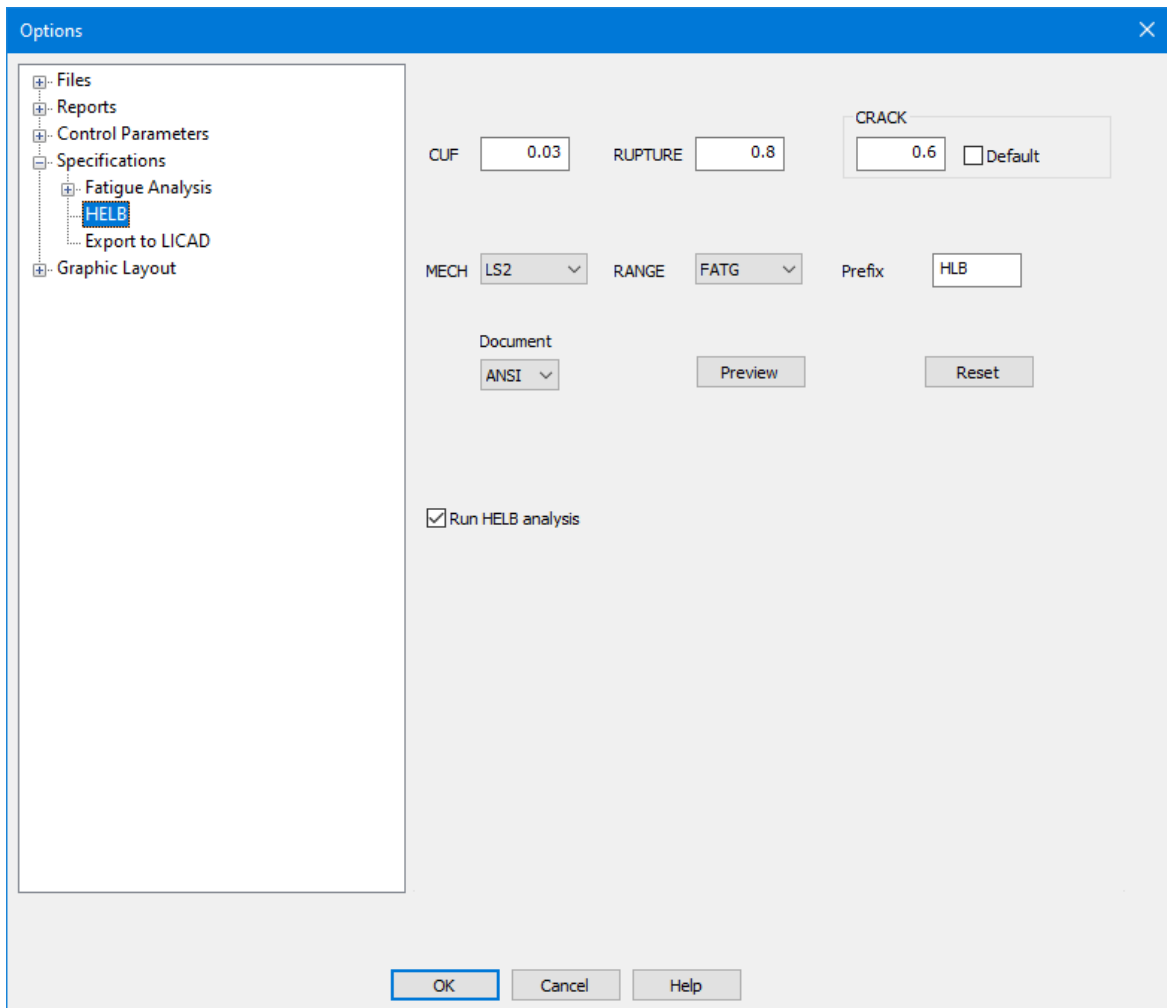

Export to LICAD

**Export to LICAD tab:** specification for the export of loads acting on piping supports from dPIPE to LICAD. See [Appendix XVI](#)

Dialog field	Command	Parameter
LICAD Version	DP2LCD	<a href="#">LCD_VER</a>
Skip		<a href="#">SKIP</a>
Sh Mode		<a href="#">SH_MODE</a>
Angle of support deflection		<a href="#">ANGLE</a>
Seismic category		<a href="#">S_CAT</a>
Type		<a href="#">TYPE</a>
Load 1		<a href="#">LOAD</a>
Load 2		
SF		<a href="#">SE</a>
Comment		<a href="#">NOTE</a>

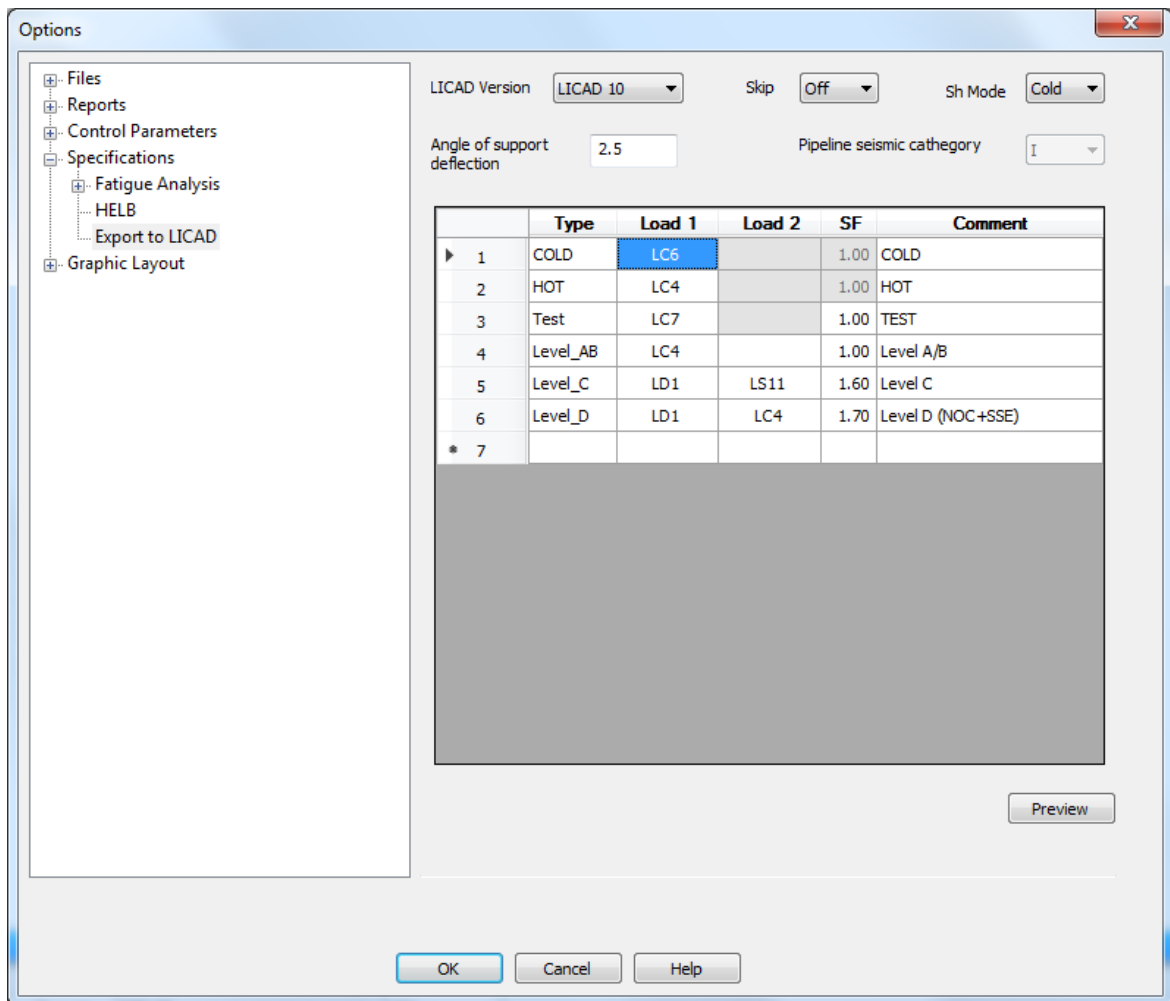

Display options

The "Display options" page is used to control the graphical representation of the model on Graphic Layout folder:

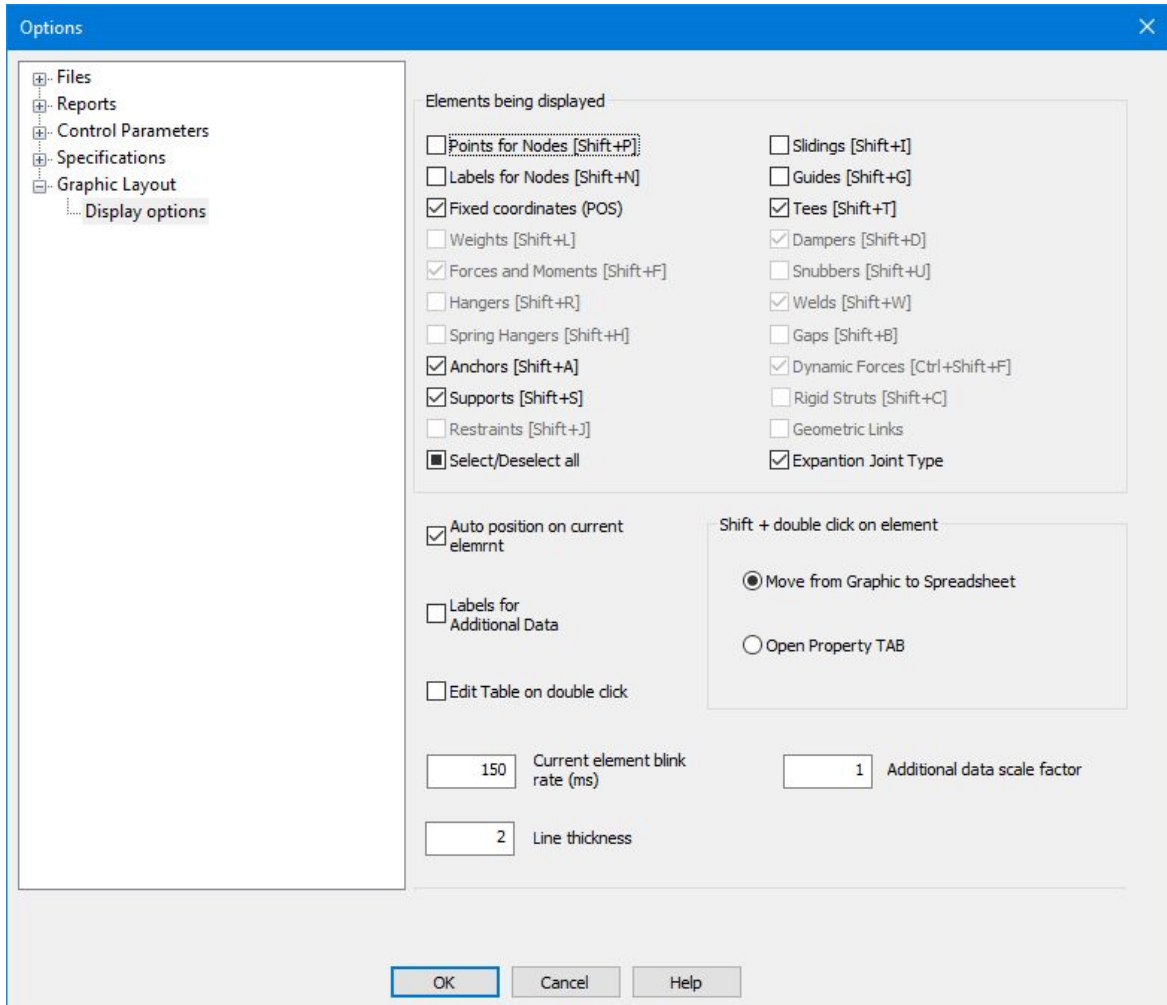

The list of "Elements being displayed" corresponds to the ["additional data"](#) set. By enabling/disabling the "**Labels for Extra Data**" flag it is possible to show/hide the labels of nodes of the elements displayed, which are related to nodes of the piping model. The flag of "**Auto position on current element**" during navigation over the spreadsheet allows synchronizing the movement over the spreadsheet and display of the model's segment being viewed. The "**Current element blink rate**" field allows regulating the blinking frequency of the element, on which the cursor is placed in the spreadsheet. In case when 0 is entered, the blinking will stop. "**Additional data scale factor**" allows entering the scaling coefficient in order to zoom in/out the additional data in the program window.

Watch Video

Activating the "**Edit tables on double-click**" option allows you to avoid the system "beep" signal when double-clicking on fields in the "[Add. data](#)", "[Section](#)" and "[Load Group](#)" columns of the "[Layout](#)" table. The "**Line Thickness**" field allows you to adjust the line thickness when displaying the piping model in line.

## Analysis



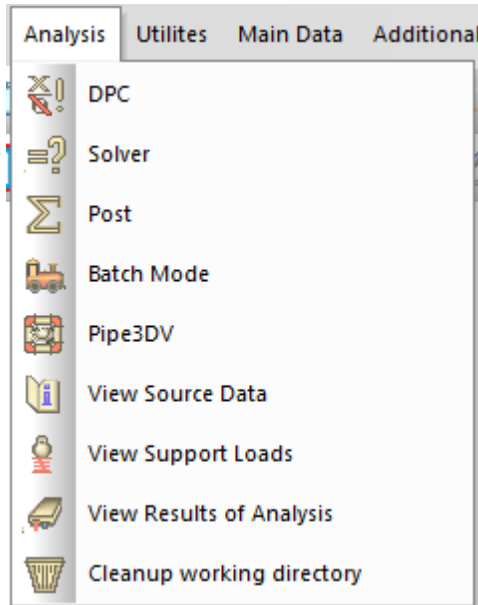



The "Analysis" menu item is a set of commands for the execution of analysis:









Menu Item	Icon on toolbar	Operation
DPC		start pre-processor and generate the input data listing
Solver		start the analysis module;
Post		start post-processor and generate the results;
Batch Mode		execute all the above-mentioned command in batch mode;
Pipe3DV		call the PIPE3DV program for viewing the piping model and the result;
View the input data listing		view file with input data listing (*.OUT)
Loads on supports		view file with summary tables of loads on supports, equipment and valves (*.SUP)
View the results listings		view file with printout of the results (*.RES)
Clear the working directory		Clear the working directory from temporary files to be created by the program by running the <i>clear.bat</i> file

## Utilities

Auxiliary stand alone programs:

Utilities	Main Data	Additional I
 TCalc		
 CVSpec - TH		
 DmpView		
 G-Frc		
 Rampa => dPIPE 5		
 PCF2DP		

TCalc		Pressure Design Calculator (supports Russian PNAE and RD codes). May be used as a stand-alone application. Requires licensing for the full functionality mode.
CVSpec-TH		software for developing and processing the Seismic Response Spectra, as well for generation of artificial acceleration Time Histories, see: <a href="https://www.dpipe.ru/en/dpipe_utilities_en/cvspecth_en.html">https://www.dpipe.ru/en/dpipe_utilities_en/cvspecth_en.html</a> . May be used as a stand-alone application. Requires licensing for the full functionality mode.
DmpView		view and manage data and characteristics of viscoelastic dampers;
G-Frc		dPIPE utility for evaluation of the fluid forces arisen due to sudden pipe break according to the requirements of <a href="#">REF 19, 20</a> . The program allows to evaluate thrust forces and Jet Impingement Effects. May be used as a stand-alone application. Requires licensing for the full functionality mode. See: <a href="https://www.dpipe.ru/en/dpipe_utilities_en/g-frc_en.html">https://www.dpipe.ru/en/dpipe_utilities_en/g-frc_en.html</a>
RAMPA => dPIPE 5		Conversion of Input Data from the RAMPA program into the dPIPE5 data format (run the R2DP_N.exe program). In case of Input Data conversion from RAMPA-93 and RAMPA-90, the initial file shall have the extension of ".dat" and ".nml" respectively. In case of successful execution of the program, a file with the same name as the converted file will be created in the working directory but with the ".dp5" extension. For further operation this file shall be loaded into the <a href="#">DDE</a> spreadsheet.
PCF2dP		The preprocessor module for converting data from PCF (Piping Component Files) into dPIPE models, see <a href="#">PCF2dP User Manual</a> .
dPIPE -> dPIPE 5		Converting input data from an older version of dPIPE to the dPIPE5 data format (run DP2DP5.exe. The program is located in the "UTILS" folder. To run from the command line: DP2DP5.exe <Source file> <dp5 file>). The source file must have the ".dat" extension. If the program runs successfully, a file with the same name as the converted file, but with the ".dp5" extension, is created in the working directory. For further work, this file must be loaded into the DDE table.

## Main Data

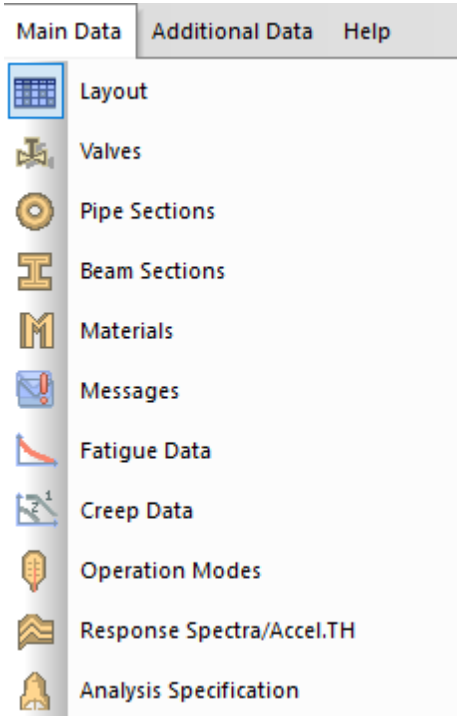

The "**Main data**" menu allows to switch over between main active program windows:



**Layout** - [geometry input window](#)

**Valves** – view and edit the characteristics of the valves (see [V](#), [V1](#), [V2](#), [VA](#), [VO](#) commands):

	Nodes	Designation	Type	W1	W2	W3	Wop	Data Base	Lr
58	37610-37620	10LBU30BS101	General	10000					
59	37750-37760	57!!!	General					114	
60	24010-24350	10LBA40AA101	General	627.2				114	
61	25100-25110	10LBA40AA401	General	78.4				93	
62	37460-26570	10LBU40AA502	General	125.44				113	
63	26590-26600	10LBU40AA501	General	125.44				113	
64	26680-26690	LBA40 EPY-A	Left Half	6621				103	
65	26690-26700	LBA40 EPY-A	Right Half	6621				104	
66	37630-37640	10LBU40BS101	General	10000					

The window can also be activated by pressing the  button. The  button allows to set permissible loads on the valve's nozzle (see [Appendix X](#)). In order to call the individual dialog for each valve, the "Properties" item of the spreadsheet context menu is used (to be called by right click).

**Pipe Sections** – input of the characteristics of pipe cross-sections (see [PIPE](#) command):



Pipe Sections. Code: EN

	Name	Diameter	Wall Thickness	Weight of pipe	Material	Insulation Weight	Core
1	813_pipe	813	10	1.94203	P235GH_s10	0.1868	No
✓ 2	1219_pipe	1219	20	5.79949	P235GH	0.2735	No
3	1219_bend	1219	25	7.21912	P235GH	0.2735	No

Std. bend	Name	Radius	Section
1	1829	1829	1219_pipe

Navigation: Bends Tees

The window can also be activated by pressing the  button. In operations with this spreadsheet it is possible to add data from the database [pipe.dbs](#) (  button) or export data to another database (  button):

Select Pipe Section

Name	Diameter	Wall Thickness	Material	Document
P200	219	20	P265GH_t40	EN10253-2:2007
P250	273	25	P265GH_t40	EN10253-2:2007

Buttons: Add Close Help

At the bottom of the window there are tabs for the piping fittings ("standard" elements), coupled with the current section of the pipe. Tab "Bends" corresponds to the parameter [BEND](#) :

Pipe Sections. Code: PNAE

	Name	Diameter	Wall Thickness	Weight of pipe	C	Material
✓	1 408x3	408	3	0.296464	0.3	12X18N10T
	2 325x3	325	3	0.235707	0.3	12X18N10T

Std. bend	Name	Radius	Out-of-round.	Smin	Section
1	R806_408x3	806		3	408x3

Bends Tees

While tab "Tees" corresponds to the [TEE](#) parameter:

Pipe Sections. Code: PNAE

	Name	Diameter	Wall Thickness	Weight of pipe	C	Material	FW1	FW2	Fi s	Insulation Weig
✓	1 408x3	408	3	0.296464	0.3	12X18N10T	0.8	0.8	1	0.00
	2 325x3	325	3	0.235707	0.3	12X18N10T	0.8	0.8	1	0.00



Std. Tee	Name	DR	TR	Length	Section	DB	TB	Height	Weight	Material
1	UFTS01	408	3		408x3	408	3			12X18N10T
2	UFTS02	408	3		408x3	408	3		3000	12X18N10T
3	FWB	408	3		408x3	408	3		5000	12X18N10T
4	FWBS02	408	3		408x3	408	3		6000	12X18N10T

Bends Tees

**Beam Sections** – input of the characteristics of cross-sections for beam elements (see [BEAM](#) command):

Beam Sections

	Name	Ax	Sy	Sz	bx	ly	lz	Weight
1	LComer_1	176.375	0.42	0.42	100.3	35310	9310	1.12097
2	Comer_hole2	118.75	0.3	0.3	178.878	12360	4364	0.010399
3	Comer_hole	176.375	0.42	0.42	100.3	35310	9310	0.010399
4	Beam_2_comer	605	0.436	0.415	5000.25	368000	95200	0.0471861
5	Tray_1	1737.5	0.510051	0.267856	3918.19	4.24661E+007	3.72521E+006	1.1485
6	Tray_2	1737.5	0.510051	0.267856	3918.19	4.24661E+007	3.72521E+006	0.44145
7	C_section_hole	231.25	0.7311	0.2184	355.6	115630	20100	0.0122625
8	Kronstein_1	202	0.72948	0.081	387.54	54731	32169	0.0111834

The window can also be activated by pressing the  button. In operations with this spreadsheet, it is possible to add data from the database (  button) or export data to another database (  button).

**Materials** – input of the characteristics of materials to be used in piping model (see [MAT](#) command):

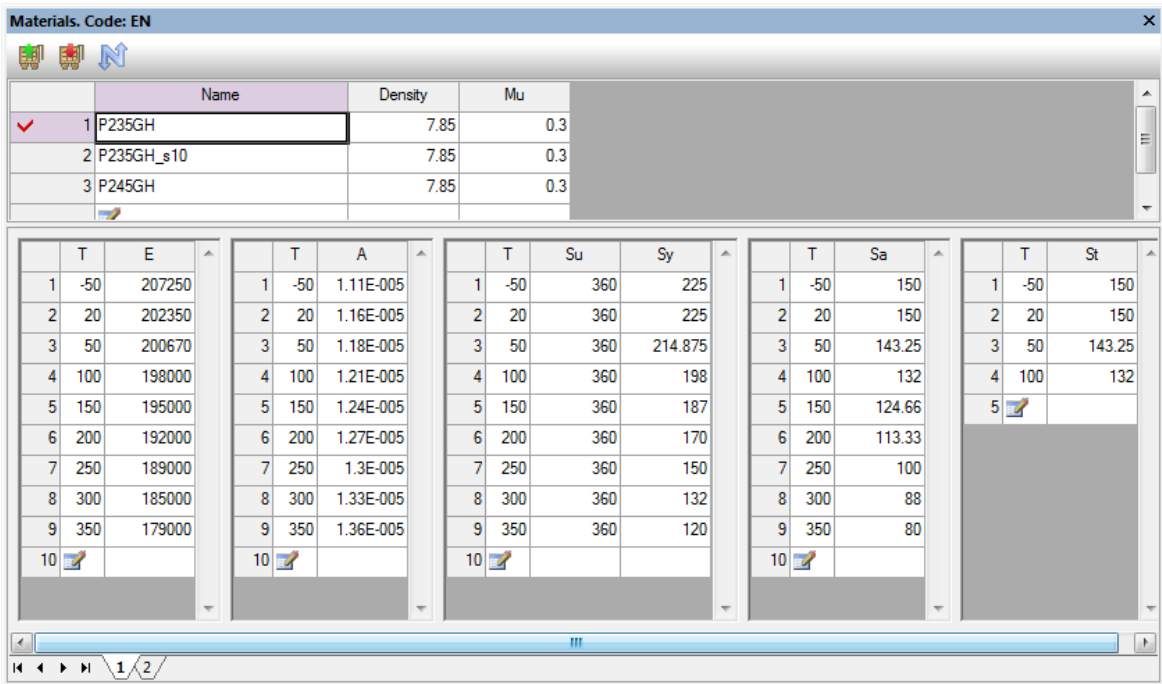

Materials. Code: EN			
	Name	Density	Mu
✓	1 P235GH	7.85	0.3
	2 P235GH_s10	7.85	0.3
	3 P245GH	7.85	0.3



T	E
1	-50 207250
2	20 202350
3	50 200670
4	100 198000
5	150 195000
6	200 192000
7	250 189000
8	300 185000
9	350 179000
10	

T	A
1	-50 1.11E-005
2	20 1.16E-005
3	50 1.18E-005
4	100 1.21E-005
5	150 1.24E-005
6	200 1.27E-005
7	250 1.3E-005
8	300 1.33E-005
9	350 1.36E-005
10	

T	Su	Sy
1	-50 360 225	
2	20 360 225	
3	50 360 214.875	
4	100 360 198	
5	150 360 187	
6	200 360 170	
7	250 360 150	
8	300 360 132	
9	350 360 120	
10		

T	Sa
1	-50 150
2	20 150
3	50 143.25
4	100 132
5	150 124.66
6	200 113.33
7	250 100
8	300 88
9	350 80
10	

T	St
1	-50 150
2	20 150
3	50 143.25
4	100 132
5	

The window can also be activated by pressing the  button. In operations with this spreadsheet, cross-sections can be added from the database (  button) or export into another database (  button).

The **"Messages"** window contains information about errors arising in the course of reading the Input Data file. The window will be activated automatically in case when an error occurs:

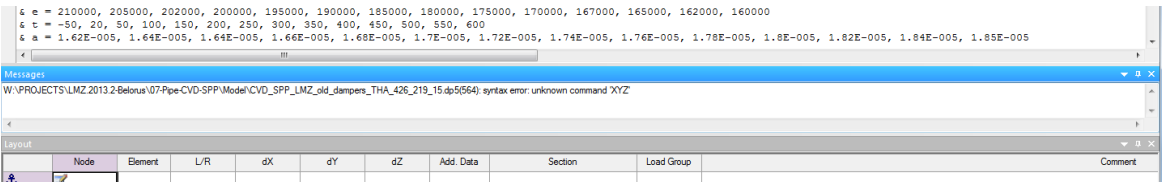

```

& e = 210000, 205000, 202000, 200000, 195000, 190000, 185000, 180000, 175000, 170000, 167000, 165000, 162000, 160000
& c = -50, 20, 50, 100, 150, 200, 250, 300, 350, 400, 450, 500, 550, 600
& a = 1.62E-005, 1.64E-005, 1.64E-005, 1.66E-005, 1.68E-005, 1.7E-005, 1.72E-005, 1.74E-005, 1.76E-005, 1.78E-005, 1.8E-005, 1.82E-005, 1.84E-005, 1.85E-005

```

Messages  
W:\PROJECTS\LMZ.2013.2\Belorus\07Pipe-CVD-SPP\Model\CVD\_SPP\_LMZ\_old\_dampers\_THA\_426\_219\_15.db\5564) syntax error: unknown command XYZ

Node	Element	L/R	dX	dY	dZ	Add. Data	Section	Load Group	Comment

Double click on the message line switches the graphics (main) window to the text mode and places the cursor on the line, in which the error is detected:

```

3140: RX len = 816
665F: P len = 1200 6709

2470: F dc = -1, 0, 0, cs = '820x9', lg = 'LG1'
3150: RX len = 816

3030: F dc = -1, 0, 0, cs = '1020x10', lg = 'LG1', name = "Отбор на бойлер N2"

```

Messages



W:\PROJECTS\LMZ.2013.2-Belorus\07-Pipe-CVD-SPP\Model\CVD\_SPP\_LMZ\_old\_dampers\_THA\_426\_219\_15\_dp5(430): syntax error: unknown parameter '6709'.

The **"Fatigue Data"** window contains information about the data being necessary for fatigue analysis (see [FAT](#) command). The window can also be activated by pressing the  button:

**Fatigue Curves**

Name	EM	Interpolation
1 FAT1	175000	Log-Log
2 AUS	173000	Log-Log
✓ 3 CS	195000	Log-Log

	Nc	Sa
1	10	2100
2	20	1700
3	50	1100
4	100	820
5	200	650
6	500	460
7	850	380

In operations with this spreadsheet, it is possible to add data from the database ( button) or export data to another database ( button).



- The **"Creep Data"** window contains information about the data being necessary for the analysis of high temperature piping systems (see [CREEP](#) commands). The window can also be activated by pressing the  button:

**Creep Data**

Name
✓ 1 SC2
2 SC1

	T	Hi
1	370	0.725
2	490	0.615
3	500	0.6
4	520	0.56
5	540	0.51
6	560	0.45

	T	Delta
1	370	0.605
2	380	0.61
3	390	0.62
4	410	0.64
5	450	0.7
6	490	0.78

In operations with this spreadsheet, it is possible to add data from the database (  button) export data to another database (  button).

The "Operation Modes" window contains information about various operating modes of the piping system with specification of the load groups being assigned to the different piping segments (see [OPVAL](#) command). The window can be activated either from the menu or by pressing the  button:

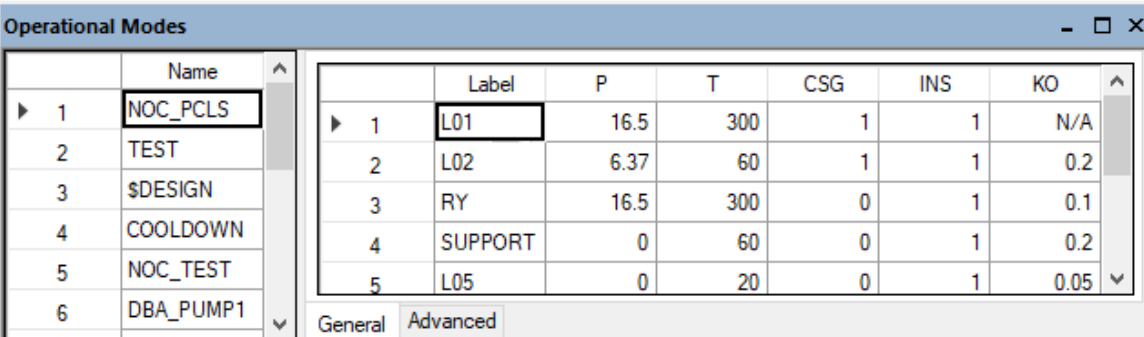

	Name
▶ 1	NOC_PCLS
2	TEST
3	\$DESIGN
4	COOLDOWN
5	NOC_TEST
6	DBA_PUMP1

	Label	P	T	CSG	INS	KO
▶ 1	L01	16.5	300	1	1	N/A
2	L02	6.37	60	1	1	0.2
3	RY	16.5	300	0	1	0.1
4	SUPPORT	0	60	0	1	0.2
5	L05	0	20	0	1	0.05

The type of dialog depends on the Code used for analysis. So, for those Codes that deal with elevated temperature piping ([CODE](#)='RD/EN/PNAE\_T'), an additional fields become available for entering the service life both for the entire mode and for individual load groups within the mode:

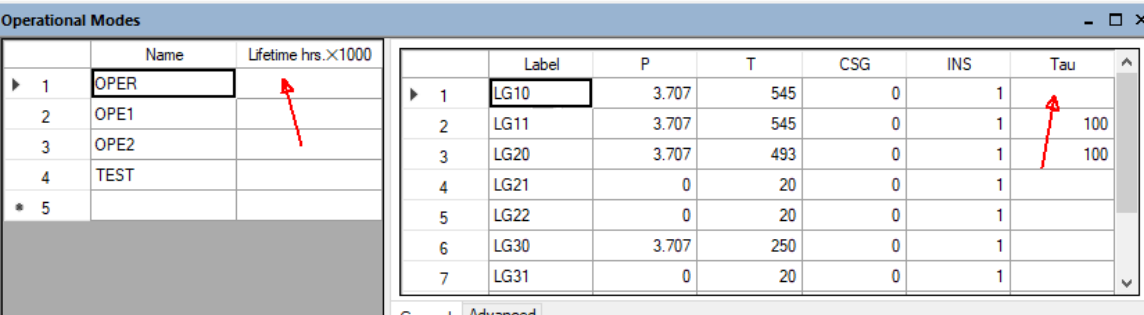

	Name	Lifetime hrs. x1000
▶ 1	OPER	
2	OPE1	
3	OPE2	
4	TEST	
* 5		

	Label	P	T	CSG	INS	Tau
▶ 1	LG10	3.707	545	0	1	
2	LG11	3.707	545	0	1	100
3	LG20	3.707	493	0	1	100
4	LG21	0	20	0	1	
5	LG22	0	20	0	1	
6	LG30	3.707	250	0	1	
7	LG31	0	20	0	1	

The "Advanced" tab is used to enter the data required to calculate the stresses due to the temperature gradient across the wall thickness and the effect of stratification ([GRAD](#) command):

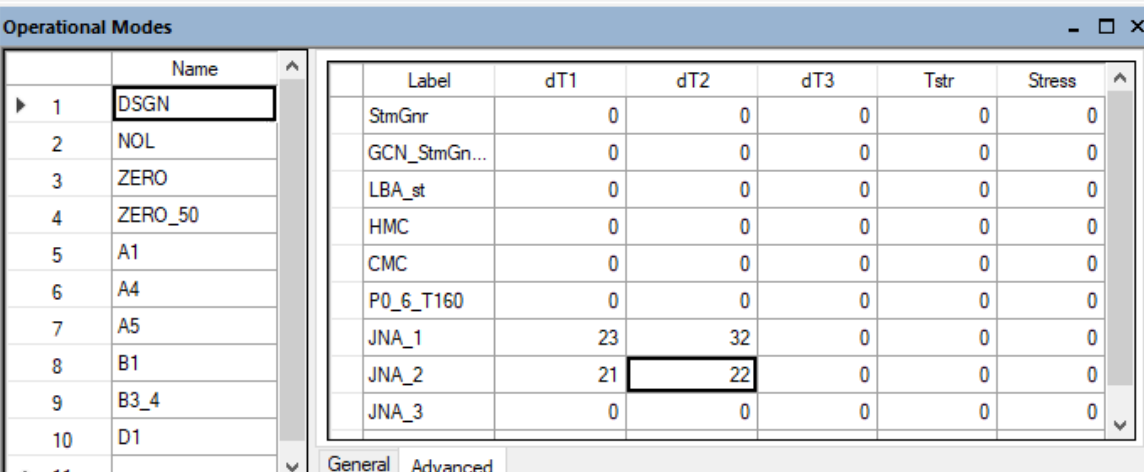

	Name
▶ 1	DSGN
2	NOL
3	ZERO
4	ZERO_50
5	A1
6	A4
7	A5
8	B1
9	B3_4
10	D1
* 11	

	Label	dT1	dT2	dT3	Tstr	Stress
	StmGnr	0	0	0	0	0
	GCN_StmGn...	0	0	0	0	0
	LBA_st	0	0	0	0	0
	HMC	0	0	0	0	0
	CMC	0	0	0	0	0
	P0_6_T160	0	0	0	0	0
	JNA_1	23	32	0	0	0
	JNA_2	21	22	0	0	0
	JNA_3	0	0	0	0	0

The "**Response Spectra/Accelerograms**" window contains data for the seismic input expressed in the form of response spectra ([RSM](#) analysis, see [SPEC](#) command), or accelerations time histories records ([THA](#), [ACCE](#) command). The window can be activated either from the menu or by pushing the  button:

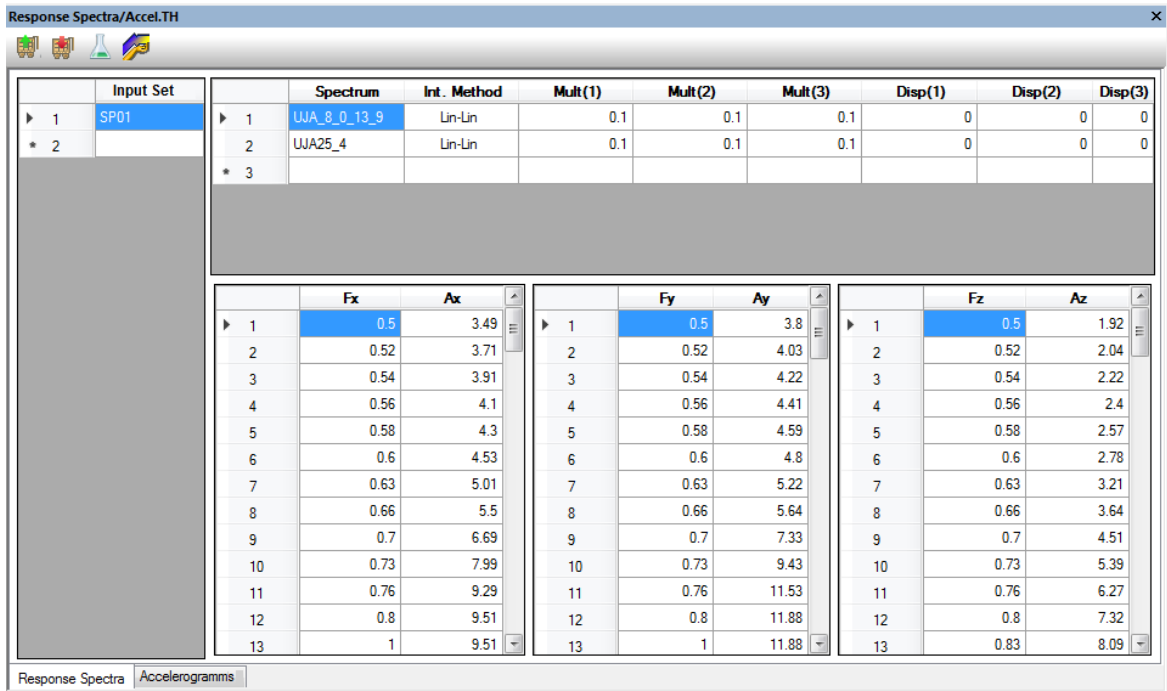

Input Set		Spectrum	Int. Method	Mult(1)	Mult(2)	Mult(3)	Disp(1)	Disp(2)	Disp(3)
▶ 1	SPD1	UJA_8_0_13_9	Lin-Lin	0.1	0.1	0.1	0	0	0
* 2		UJA25_4	Lin-Lin	0.1	0.1	0.1	0	0	0
* 3									

  

	Fx	Ax	Fy	Ay	Fz	Az
▶ 1	0.5	3.49	0.5	3.8	0.5	1.92
2	0.52	3.71	0.52	4.03	0.52	2.04
3	0.54	3.91	0.54	4.22	0.54	2.22
4	0.56	4.1	0.56	4.41	0.56	2.4
5	0.58	4.3	0.58	4.59	0.58	2.57
6	0.6	4.53	0.6	4.8	0.6	2.78
7	0.63	5.01	0.63	5.22	0.63	3.21
8	0.66	5.5	0.66	5.64	0.66	3.64
9	0.7	6.69	0.7	7.33	0.7	4.51
10	0.73	7.99	0.73	9.43	0.73	5.39
11	0.76	9.29	0.76	11.53	0.76	6.27
12	0.8	9.51	0.8	11.88	0.8	7.32
13	1	9.51	1	11.88	0.83	8.09

In order to add response spectrum from the existing text files, it is necessary to use the  button. The files shall contain digital response spectrum in the "frequency - acceleration" format. Vice

versus, for the export of the spectrum data to the external file the button  should be used. In this case, instead of digital data, the relative or absolute links will be written in the \*.dP5 file.

### All accelerations scaled by "mult" should be expressed in g (gravity)!!!

The button  is used to launch [CVSpec-TH](#) program for viewing and processing of the response spectra, and acceleration time history records. The program also can generate artificial acceleration time histories from the given response spectra.

Watch Video

The "**Analysis Specification**" window is used to specify the sequence of the required analyses (Load Cases) and post-processor directives (Load Sets). The input shall be performed in the tabular form according to instructions given for [SOLV](#), [POST](#) and [DCASE](#) commands:

Analysis Specification (Untitled). Code: EN.

Spring Design. Stress Analysis (#1)

	Type	Mode	Load	Pend.	Fric.	NLS	Hng. Stf.	PE	SBP	Note
▶ LC1	DSGN	\$OPER	W	No	<input type="checkbox"/>	Yes	<input type="checkbox"/>	<input type="checkbox"/>	<input type="checkbox"/>	Spring Hangers Design Loads
LC2	OPER_A	\$OPER	W+P+T+D	No	<input type="checkbox"/>	Yes	<input type="checkbox"/>	<input type="checkbox"/>	<input type="checkbox"/>	Hot Load. Selection of springs
LC3	OPER_B	\$COLD	W+P+T+D	No	<input type="checkbox"/>	Yes	<input checked="" type="checkbox"/>	<input type="checkbox"/>	<input type="checkbox"/>	Cold Load. Selection of springs
LC4	OPER_B	\$OPER	W+P+T+D	Yes	<input checked="" type="checkbox"/>	Yes	<input checked="" type="checkbox"/>	<input type="checkbox"/>	<input type="checkbox"/>	Hot Load. Stage II
LC5	SUST_C	\$OPER	W+P	No	<input type="checkbox"/>	Ref.	<input type="checkbox"/>	<input type="checkbox"/>	<input type="checkbox"/>	Sustained Loads. Stage I
LC6	OPER_B	\$COLD	W+P+T+D	Yes	<input checked="" type="checkbox"/>	Yes	<input checked="" type="checkbox"/>	<input type="checkbox"/>	<input type="checkbox"/>	Cold Load. Stage IV
* LC7					<input type="checkbox"/>		<input type="checkbox"/>	<input type="checkbox"/>	<input type="checkbox"/>	

	Type	Rule	Print	Load Set	Comment
▶ LS1	SGM1	SUM	<input checked="" type="checkbox"/>	LC5	SGM1
LS2	SGM3	SUM	<input checked="" type="checkbox"/>	LC4-LC6	SGM3
LS3	SGM4	SUM	<input checked="" type="checkbox"/>	LC5+LS2	SGM4
LS4	DISP	SUM	<input checked="" type="checkbox"/>	LC5	Weight deflections
LS5	DISP	SUM	<input checked="" type="checkbox"/>	LC4-LC6	Thermal expansions
LS6	SUPP	SUM	<input checked="" type="checkbox"/>	LC4	Hot Loads
LS7	SUPP	SUM	<input checked="" type="checkbox"/>	LC6	Cold Loads
* LS8			<input type="checkbox"/>		

Postprocessor Dynamic Analyses

The buttons in the dialog header allow defining the Stress Evaluation Code ([CODE](#)), import the standard calculation's set from the solv.dbs file, export the user-defined set to the custom's database and viewing the commands in the text form:



## Additional data

The next group of windows contains the data related to the Nodes of Piping Calculation Model presented in the tabular form. The windows can be opened from the drop-down menu ("**Additional data**" item):

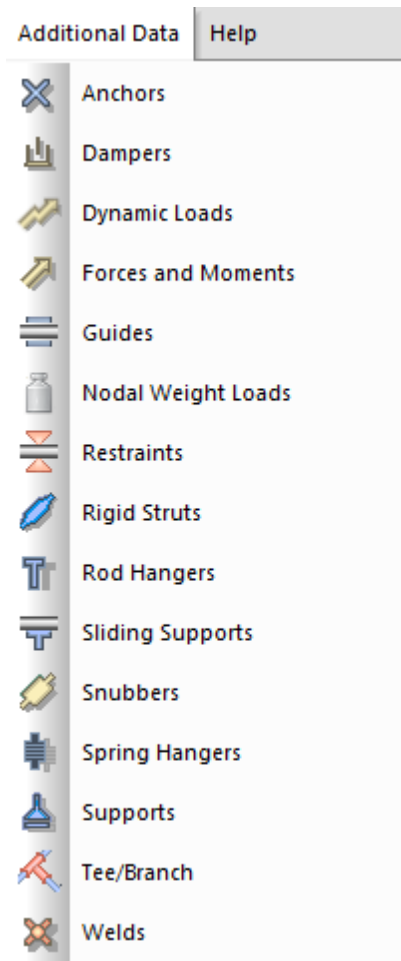

The menu items and dPIPE commands are correlated as follows:

Anchors	<a href="#">ANC</a>
Dampers	<a href="#">DMP</a>
Dynamic Loads	<a href="#">DFRC</a>
Forces and Moments	<a href="#">FOR</a>
Guides	<a href="#">STG, STG-</a>
Nodal Weights	<a href="#">CW</a>
Restraints	<a href="#">STS, SRS, STS+/-</a>
Rigid Struts	<a href="#">STRI</a>
Rod hangers	<a href="#">ROD</a>
Sliding Supports	<a href="#">STZ, STZ-</a>
Snubbers	<a href="#">SNUB</a>
Spring Hangers	<a href="#">SPR</a>
Supports	<a href="#">SUP</a>
Tees/Branch	<a href="#">TEE</a>
Welds	<a href="#">WLD</a>

In operations with "additional data" presented in the tabular form, there is the possibility to "disable" them within the analysis performed. For this purpose, it is necessary to double click over the grey field with the sequential number of element:

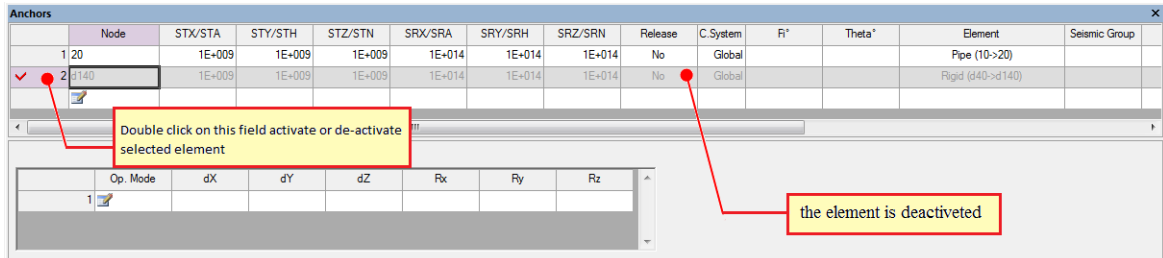

In doing so, the corresponding line in the Input Data file is commented by two ";" signs. Any subsequent inclusion of elements in Piping Calculation Model occurs similarly. Such working method is convenient in variants calculations.

Additional data are presented in the form of summary tables that display the most important fields of their properties. The "Properties" item of the context menu (to be called by right click) in any of spreadsheets with additional data allows opening the dialog with full properties of the component considered:

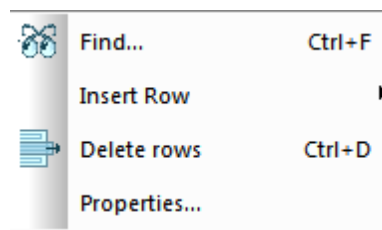

Summary tables can be copied to the clipboard. The command CTRL-C copies only the contents of the table. The command CTRL-Shift-C copies the contents of the table with the heading row of the table. Clipboard contains also commented out (disabled) elements. In this case the last column of the copied table will contain symbol "!".

## Help

The following topics are available under this menu item:

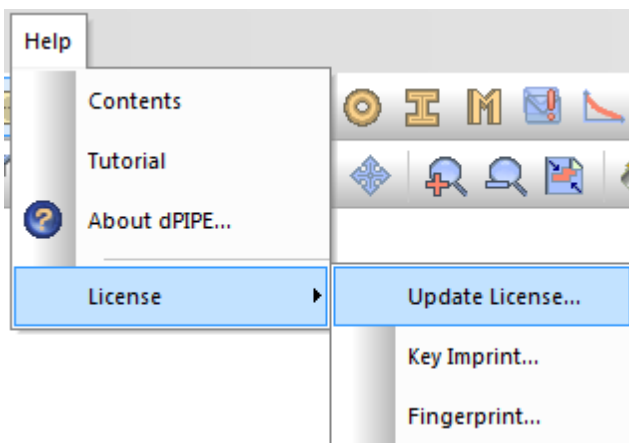

- Contents: lunch help file for dPIPE 5

- Tutorial: lunch help with dPIPE Tutorial
- About dPIPE: shows a window with information about the program's release and build, used protection key and number of used licenses:

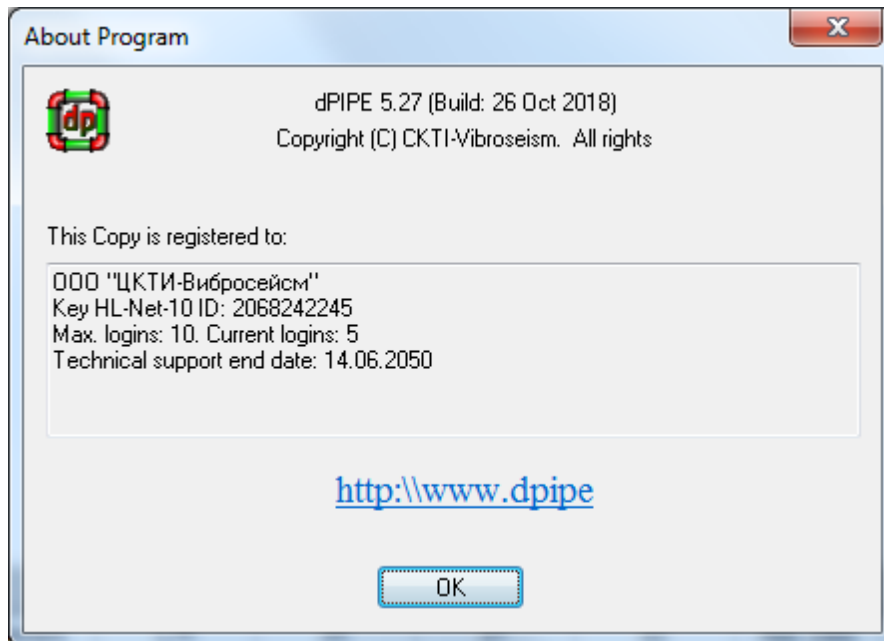

The item "License" contains sub-items for working with security keys (see the section "[Protection keys and License Management](#)")

## 8 Input data language

The language for description the input data for the dPIPE 5 program consists of commands. The commands can contain internal subcommands as well as parameter subcommands and parameters, which values can be individual values or arrays.

### Types of commands

The commands describe both general data relating to the whole model or a part thereof and local data referenced to a particular node or elements of the analysis model. Depending upon the availability of internal subcommands, general commands can be divided into one-line commands (without internal subcommands) and multi-line commands containing internal subcommands or parameter subcommands. Each command (subcommand) shall be located in a separate line. Before specification of a local command it is necessary to indicate the label of the node with subsequent colon.

### Parameter values

The following types of parameter values can be distinguished:

- Numbers – integers (hereinafter designated as **INTEGER**) and real numbers (hereinafter designated as **REAL**). Real values can be written both in real form and in exponential form.

Example : 3, .3, -3.3, 3.2e-2

- Text – a set consisting only of alphanumeric characters enclosed in simple quotes (hereinafter designated as **TEXT**). The maximum length of the text type parameter value is limited by 16 characters. In the text data, the upper case letters and the lower case letters are equal. No space

or tab are permitted inside the text data. The following restrictions apply when entering text data in [DDE](#):

- a) only letters of the Latin alphabet are allowed;
- b) except letters the following symbols are allowed: **#** **\$** **\*** **\_**

**Example:** '108x9', '08H18N10T'

- String – a set of characters enclosed in double quotes (hereinafter designated as **STRING**). The maximum length of the STRING type data is limited by 64 characters. In the string type data, the upper case letters and the lower case letters are different. The availability of spaces and special characters is permitted.

**Example:** "10RA01 piping system"

### Node labels

The analysis model node labels are text variables with the length up to 8 characters. In describing the node marks, the upper case letters and the lower case letters are equal.

### Delimiters

The following characters are used as delimiters between the data being entered: «\_» spaces, «,» commas or tabulation characters. Several spaces and/or tabulation characters entered successively shall be interpreted as one delimiter. A comma shall directly follow the magnitude entered. It is allowed to use the «=» character between the name of parameter and its value.

### Special characters and commands

";" is the comment character. All information after the «;» character up to the end of the current line will not be perceived by the program; the «;» character is followed by the transfer to the next line.

"\", the backslash character, is used for delimiting lines in the command. Pre-processor "glues" the previous and next lines and interprets several lines as one line. It should be kept in mind that the «;» comment character can immediately follow the line delimitation character.

**Example :**

```
T = 20 50 100 150 200 250 300 350 400 450 500 550
600
```

is equivalent to

```
T = 20 50 100 150 200 250 300 350 400 \
450 500 550 600
```

& is the symbol of the beginning of a subcommand or a parameter command. It is used only in multi-line commands and shall be placed directly before the name of subcommand (parameter command).

### Parameter input sequence

In case of explicit indication of the name, the parameters inside one command (subcommand) can be entered in arbitrary order. It is allowed to enter parameters without name provided that the parameters entered are passing in the order determined herein. As soon as a named parameter is encountered within one command, all subsequent parameters shall be entered with their names.

### Language commands

The description of commands of the input data entry language is given below. The parameters or subcommands, for which no default value has been determined, shall be mandatory. They are highlighted in the text in red bold type, for example, **T** .

### System of Units

dPIPE uses a consistent system of units. Basic Newton (N) and millimeter (mm) are used by default. All other units are derived from these two:

- displacements, sizes, thickness, etc: mm;
- accelerations: in parts of g (acceleration of gravity);
- forces: Newton
- rotation angles: radians or degrees, (as specified in this manual)
- pressure, stresses: N/mm<sup>2</sup> or MPa;

The following designations have been used in the text hereof:

- rigid** – "absolutely rigid" (the stiffness value is determined in accordance with the [RGD\\_TRN](#) and [RGD\\_ROT](#) parameters)
- blank** – "empty line"

### [General commands](#)

#### [Local commands](#)

## General commands

[Insert data from another file \(INCLUDE\)](#)

[Analysis title \(TITLE\)](#)

[Control parameters \(CTRL\)](#)

[Cyclic strength curves \(FAT\)](#)

[Curves for high temperature piping system analysis \(CREEP\)](#)

[Materials \(MAT\)](#)

[Pipe cross-section characteristics \(PIPE\)](#)

[Beam element cross-section characteristics \(BEAM\)](#)

[Piping system operating modes \(OPVAL\)](#)

[Stresses from the temperature drop over the wall thickness and from the stratification effect \(GRAD\)](#)

[Data for spring supports \(SDEF\)](#)

[Seismic response spectrums \(SPEC\)](#)

[Seismic load accelerograms \(ACCE\)](#)

[Specification for Analysis \(SOLV\)](#)

[Specification for post-processing \(POST\)](#)

[Specification for fatigue strength analysis \(FATG\)](#)

[Specification for report generation \(POST\\_REP\)](#)

[Managing the databases connected \(DBF\)](#)

[Suppressing results by headers \(\\$NOHEAD\)](#)

[End of input data \(END\\_OF\\_DATA\)](#)

## Insert data from another file (INCLUDE)

The INCLUDE command allows connecting the data contained in another file to the file with input data. The command syntax is as follows:

```
INCLUDE "file"
```

*file* is the file name and its path written in double quotes. If the file is indicated without path, then the program attempts to find it either in the current directory or in the directory, in which the program is installed.

## Model title (TITLE)

**type:** general one-line command

**Function:** title for printout

### Parameters:

"text" title for printout

type: [STRING](#)  
unit: -  
default value: [blank](#)  
limitations: -

Example: TITLE "Feed water piping analysis"

## Control parameters (CTRL)

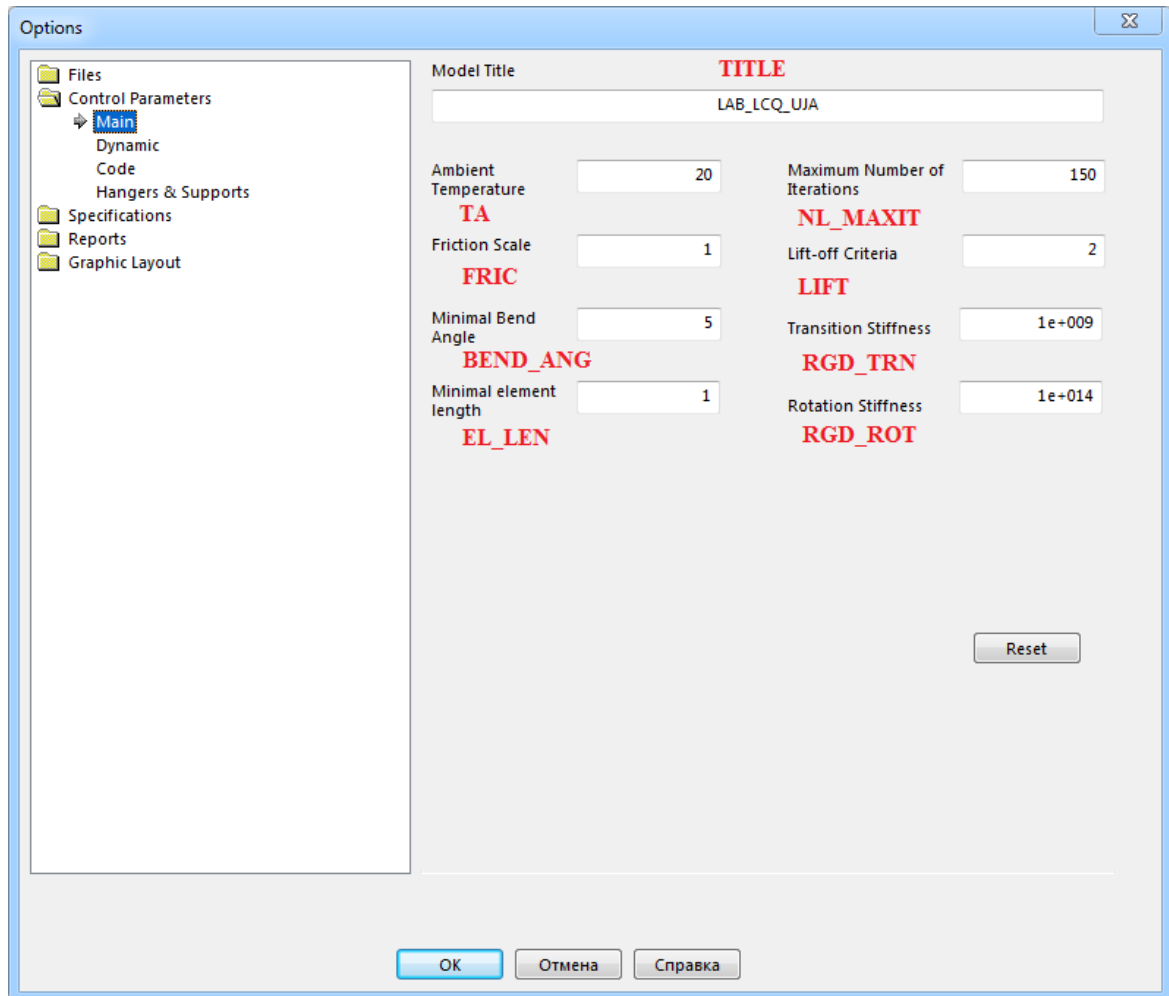

**type:** general one-line command

**Function:** determine control parameters for analysis

### Parameters:

**TA** is the piping system installation (ambient) temperature. It is used for determination of the characteristics of piping system in the "cold" state. If it is required to determine the installation temperature of various piping segments, the mode with the '\$INST' predefined name ([OPVAL](#) command) should be used, in which it is possible to set the individual temperature for each load group.

type:	<a href="#">REAL</a>
unit:	°C
default value:	20°C
limitations:	from -50°C to +60°C

**NC** is the number of cycles. It is used for fatigue analysis.

Type:	<a href="#">INTEGER</a>
-------	-------------------------

Unit: -  
 Default value: see [Default values](#) Table  
 Range of possible values: from 1 to  $1 \cdot 10^7$

**DYN** is the dynamic analysis flag

Type: [TEXT](#)  
 Unit: -  
 Default value: 'NO'  
 Range of possible values: 'NO', 'RSM', 'THA'

'NO' - dynamic analysis is not performed;  
 'RSM' – seismic load analysis by the Response Spectrum Method,  
 'THA' – dynamic load method by the Time History Analysis method (time integration of the equations of motion)

**FMAX** is the cutoff frequency, up to which the natural frequencies of the piping system will be computed

Type: [REAL](#)  
 Unit: Hz  
 Default value: 33  
 Range of possible values: >0

**BEND\_CODE** - option for computing the bend's flexibility factor

Type: [TEXT](#)  
 Unit: -  
 Default values: see [Default values](#) Table  
 Range of possible values: 'PNAE/RD', 'ASME', 'CASE'

'PNAE/RD' – flexibility factor to be computed according to Russian PNAE [\[REF 1\]](#) and RD 10-249-98 [\[REF 2\]](#),  
 'ASME' – analysis according to ASME codes [\[REF 3\]](#);  
 'CASE' – determination of the factor according to ASME CODE CASE N-319-3

**FRIC** - scaling factor to change friction coefficient in supports

Type: [REAL](#)  
 Unit: -  
 Default values: 1  
 Range of possible values:  $\geq 0$

*By means of this factor, it is possible to change the value of MU friction coefficients in all one-component or guide supports. It is recommended to use it for evaluating the effect of friction forces upon the results.*

**BEND\_PRES** - option to take into account pressure for the bend's flexibility factor

Type: [TEXT](#)

Unit:	-
Default values:	see <a href="#">Default values</a> Table
Range of possible values:	'YES', 'NO'

**T\_REF** - is the reference temperature from which the coefficient of thermal expansion is defined. It is also used to determine the 'reference' (or 'cold') modulus of elasticity  $E_{REF}$ , which is used for scaling stress ranges or amplitudes whenever required by the applicable piping codes.

Type:	<a href="#">REAL</a>
Unit:	°C
Default values:	20
Range of possible values:	from -50°C to +60°C

**W\_DEN** - density of water

Type:	<a href="#">REAL</a>
Unit:	N/mm <sup>3</sup>
Default values:	$9.80665 \cdot 10^{-6}$
Range of possible values:	$\geq 0$

*The  $W_{DEN}$  value is used for conversion of the media weight in accordance with the CSG parameter value of the [OPVAL](#) command.*

**RGD\_TRN** - the parameter corresponding to the "absolutely rigid" definition (RIGID) for translational degrees of freedom

Type:	<a href="#">REAL</a>
Unit:	N/mm
Default values:	$1 \cdot 10^9$
Range of possible values:	$\geq 0$

**RGD\_ROT** - the parameter corresponding to the "absolutely rigid" definition (RIGID) for rotational degrees of freedom

Type:	<a href="#">REAL</a>
Unit:	N*mm/rad
Default values:	$1 \cdot 10^{14}$
Range of possible values:	$\geq 0$

**PSHEAR** - option for the shear for straight pipe (0 - no shear allowance, > 0: shear coefficient is taken equal to 2)

type:	<a href="#">REAL</a>
unit:	-
default value:	2
limitations:	$\geq 0$

**V\_STF** - a multiplier for the wall thickness in valve modeling

type:	<u>REAL</u>
unit:	-
default value:	3
limitations:	$\geq 1$

**NL\_MAXIT** - the maximum number of iterations in non-linear computations

type:	<u>INTEGER</u>
unit:	-
default value:	99
limitations:	$\geq 1$

**NL\_FTOL** - the accuracy in determination of the friction forces

type:	<u>REAL</u>
unit:	in fractions of 1
default value:	0.01 (corresponds to 1 %)
limitations:	$\geq 0$

**NL\_RTOL** - the accuracy in determination of the non-linear support reaction force

type:	<u>REAL</u>
unit:	in fractions of 1
default value:	0.01 (corresponds to 1 %)
limitations:	$\geq 0$

**NL\_STOL** - the threshold deformation value, after which the support sliding begins

type:	<u>REAL</u>
unit:	mm
default value:	0.1
limitations:	$\geq 0$

**GRAV** - dimensional value of the mass acceleration

type:	<u>REAL</u>
unit:	mm/s <sup>2</sup>
default value:	9806.65
limitations:	$> 0$

**FREQ\_TOL** the accuracy of eigenvector determination

type:	<u>REAL</u>
unit:	-
default value:	$1 \cdot 10^{-5}$
limitations:	$> 0$

**E\_MOD** - modulus of elasticity to be used for generation of the stiffness matrix (either as to the hot state – 'HOT', or as to the T\_REF temperature – 'REF')

type: [TEXT](#)  
 unit: -  
 default value: see [Default values](#) Table  
 limitations: 'HOT', 'REF'

#### CODE - piping stress analysis codes

type: [TEXT](#)  
 unit: -  
 default value: 'PNAE'  
 limitations: 'PNAE', 'PNAE\_T', 'RD', 'ASME\_NC',  
 'ASME\_NB', 'EN', 'ASME\_B311', 'NTD\_ACI',  
 'GOST-59115-A'

The CODE parameter defines the selection of the Strength analysis codes:

- 'PNAE' – analysis of low-temperature piping according to PNAE Code [[REF 1](#)];
- 'PNAE\_T' – analysis of high-temperature piping systems according to PNAE Codes [[REF 1](#)];
- 'RD' – analysis of piping systems according to RD 10-249-98 codes [[REF 2](#)];
- 'ASME\_NC' - analysis of piping systems according to ASME NC-3600 (Class 2) codes [[REF 3](#)];
- 'ASME\_NB' - analysis of piping systems according to ASME NB-3600 (Class 1) codes [[REF 3](#)];
- 'EN' - analysis of piping systems according to EN 13480-3 European codes [[REF 10](#)];
- 'ASME\_B311' - analysis of piping systems according to ASME B31.1 codes [[REF 12](#)];
- 'NTD\_ACI' - analysis of piping systems according to Czech Code NTD A.C.I. [[REF 17](#)];
- 'GOST-59115-A' - analysis according to GOST R 59115.9-2021 [[REF 24](#)] and GOST R 59115.15-2021, Appendix A [[REF 25](#)]

#### CODE\_YEAR - year of publication of the codes (edition)

type: [INTEGER](#)  
 unit: -  
 default value: see [Default values](#) Table  
 limitations: ↓

CODE	PNAE	RD	ASME_NC	PNAE_HT	ASME_B314	ASME_NB	EN	ASME_B311	NTD_ACI	GOST-59115-A
CODE_YEAR	1989	2001	1992	1989	2006	1992	2002	2008	2016	2021
	2022*		2010			2010	2020			

Note: For CODE = 'PNAE' parameter **YEAR = 2022** is retained for compatibility reasons. In the current version, it corresponds to CODE = 'GOST-59115-A'.

**OVAL(3)** - a flag of the allowance for ovality (out of roundness) in bends (Item 5.2.6.8 of RD 10-249-98 [[REF 2](#)];)

type: [INTEGER](#)  
 unit: -  
 dimension: array of 3 elements  
 default value: see [Default values](#) Table  
 limitations: 1 or 0

*OVAL(1) and OVAL(2) parameters are used only in evaluation of the piping system strength according to RD 10-249-98 codes [REF 2], see Item 5.2.6.8. OVAL(1) - whether the ovality should be increased by 1.8 times for low-temperature piping systems (1 - yes, 0 - no), OVAL(2) - whether the ovality should be taken into account if  $a \leq 3\%$  (1 - yes, 0 - no); OVAL(3) - check of stresses both with the account of actual ovality and without account of the ovality (1 - yes, 0 - no).*

**KS** - overload factor (Item 5.2.6.2.4 of RD 10-249-98 [REF 2])

type: [REAL](#)  
 unit: -  
 default value: see [Default values](#) Table  
 limitations:  $\geq 1$

**WLD\_CHK** - flag of checking all cross-sections of the piping system analysis model with the account of the reduction coefficient of the circumferential weld strength ( see FW(2) in the PIPE command), except the points corresponding to the bend center.

type: [TEXT](#)  
 unit: -  
 default value: see [Default values](#) Table  
 limitations: 'YES' or 'NO'

**HI\_E** - a factor for conversion of the coefficient of secondary (thermal) stress averaging,  $\chi$ , to be set by the CREEP command, into the  $\chi_{\ominus}$  coefficient to be used for the computation of  $s_{RK}$  stresses in bends at the analysis of high-temperature piping systems according to PNAE codes (CODE = 'PNAE\_T')

type: [REAL](#)  
 unit: -  
 default value: see [Default values](#) Table  
 limitations:  $0 < HI\_E < 1$

**SN\_T** - a flag for the computation of allowable stresses for occasional and emergency loads at the analysis of high-temperature piping systems according to PNAE codes (CODE = 'PNAE\_T')

type: [TEXT](#)  
 unit: -  
 default value: see [Default values](#) Table  
 limitations: 'YES' or 'NO'

When  $SN\_T = 'YES'$  – the strength rupture limit shall be taken into account in the computation of nominal allowable stresses  $[\sigma]$  for stresses of categories  $\sigma_2$  at the computation of  $S2\_HDR$ ,  $S2\_NNUE$ ,  $S2\_MRZ$ ,  $S2\_PZ1$ ,  $S2\_PZ2$  stresses (see the [POST](#) command). When  $SN\_T = 'NO'$  – the allowable stresses for the above-mentioned stress categories shall be calculated as for low-temperature piping systems. The allowable stresses for the  $S2\_NUE$  category shall **always** be calculated with the account of the strength rupture limit.

**FMESH** - partial frequency for automatic meshing of the piping model into finite elements

type: [REAL](#)  
 unit: Hz  
 default value: 0  
 limitations:  $\geq 0$

In case when the  $FMESH$  parameter is set to be different from zero, the program will perform automatic splitting of the "straight pipe" and "bend" type elements into smaller elements according to the following criterion:

$$L_{max} \leq \frac{1}{2} \sqrt{\frac{\pi}{2 * FMESH} * 4 \sqrt{\frac{E * I * g}{w}}}$$

where

$E$  Young modulus;  
 $I$  moment of inertia of the piping system cross-section;  
 $g$  acceleration of gravity ;  
 $w$  piping weight per length (together with the working fluid).

In doing so, the internal nodes beginning with the "a" character will appear in the model.

**LIFT** - the "uplift" criterion for one way supports bearing the weight load (supports of "[STZ](#)", "[STG](#)-" and "[STN](#)-" type)

type: [REAL](#)  
 unit: mm  
 default value: 2  
 limitations:  $\geq 0$

**ZPGA** - the zero period of ground acceleration - parameter to be used within the Seismic Margin Analysis (SMA)

type: [REAL](#)  
 unit: in fractions of the acceleration of gravity (g)  
 default value: 0  
 limitations:  $\geq 0$

**BOW\_PITCH** - the pipe slope angle with respect to the horizontal plane, above which the temperature stratification effect will not be taken into account (see [Appendix VIII](#))

type: [REAL](#)  
 unit: degrees  
 default value: 3  
 limitations:  $\geq 0$

**PNAE\_KE** - a flag for the execution of simplified elastic-plastic analysis within PNAE codes ([CODE](#)='PNAE')

type: [TEXT](#)  
 unit: -  
 default value: see [Default values](#) Table  
 limitations: 'YES' or 'NO'

**K\_OL** - amplification factor for allowable stresses used for accidental loads. It is used as a multiplier for comparison with the stresses of [SGM2](#) category (analysis according to the European Codes [[REF 10](#)], [CODE](#) = 'EN')

type: [REAL](#)  
 unit: -  
 default value: see [Default values](#) Table  
 limitations:  $\geq 1$

**EL\_LEN** - minimum permissible element length. When elements with the length smaller than [EL\\_LEN](#) are detected in the model, the program will output a warning.

type: [REAL](#)  
 unit: mm  
 default value: 1  
 limitations:  $>0$

**MIS\_MAX** - the maximum allowable value for the mismatch of dimensions found during piping tracing. If there is a mismatch greater than [MIS\\_MAX](#) in the model, the program displays a warning

type: [REAL](#)  
 unit: MM  
 default value: [EL\\_LEN](#)  
 limitations:  $>0$

**RGD\_SPR** - the stiffness of the vertical "rigid" supports to be used at the stage of determination of the design loads on spring hanger/supports (calculations No.1 and 8)

type: [REAL](#)  
 unit: N/mm  
 default value: [RGD\\_TRN](#)  
 limitations:  $>0$

**BEND\_PSTR** - pressure allowance at computation of the stress intensification factor  $i$  for bends (effective only when [CODE](#) = 'ASME\_B311'). It is recommended to include this option for thin-walled large-diameter piping systems (ASME B31.1-2007. Table D-1 Flexibility and Stress Intensification Factors, Note 5)

type: [TEXT](#)  
 unit: -  
 default value: see [Default values](#) Table  
 limitations: 'YES', 'NO'

**WLD\_SUST** - allowance for the reduction coefficient of the circumferential weld strength in the computation of stresses from sustained loads (SL). It is effective only when [CODE](#) = 'ASME\_B311'. It is recommended to include this option for piping systems operated at the temperatures causing creep

type: [TEXT](#)  
 unit: -  
 default value: see [Default values](#) Table  
 limitations: 'YES', 'NO'

**SL\_PRES** - method for the computation of stresses from pressure in the SL category stress analysis ([CODE](#) = 'ASME\_B311'): at SL\_PRES = 1

$$S_{\Psi} = \frac{PD_0}{4t_n}$$

at SL\_PRES = 2:

$$S_{\Psi} = \frac{Pd_n^2}{D_0^2 - d_n^2}$$

type: [INTEGER](#)  
 unit: -  
 default value: see [Default values](#) Table  
 limitations: 1, 2

**SA\_LBRL** - method for the computation of allowable stresses Sa for SE category stresses (stresses from secondary loads caused, for example, by thermal expansions, [CODE](#) = 'ASME\_B311').

If SA\_LBRL = 'NO', then: Sa = f(1.25Sc + 0.25Sh)  
 If SA\_LBRL = 'YES', then: Sa = f(1.25Sc + 1.25Sh-SL)

where

Sc – nominal allowable stresses for the cold state; Sh - nominal allowable stresses for the hot state; f – coefficient of strength reduction from cyclic load:

$$f = 6/N^{0.2}$$

N – number of cycles ([NC](#) parameter)

SL – stresses from permanently acting non-self-balanced loads ([POST](#) command RES = 'SL' parameter). The option will operate only when Sh > SL.

type: [TEXT](#)  
 unit: -  
 default value: see [Default values](#) Table

limitations: 'YES', 'NO'

**BRN\_RUN** - the ratio of the typical sizes of the tee connection branch and run. If the corresponding value is less than BRN\_RUN, the tee shall be considered as non-equal. It is used for [CODE](#) = 'ASME\_B311' and for [CODE](#) = 'RD'

type: [REAL](#)  
 unit: -  
 default value: see [Default values](#) Table  
 limitations:  $0 < \text{BRN\_RUN} \leq 1$

**SH\_140** - option for the limitation of allowable Sh and/or Sc stresses by the value of 140 MPa if the ultimate tensile strength SU ([MAT](#) command) exceeds the value of 480 MPa. In case of explicit setting of SU, the limitation will occur by default. If SU is not determined in the material properties, the program will compute the Sh/Sc stresses depending upon this option

type: [TEXT](#)  
 unit: -  
 default value: see [Default values](#) Table"  
 limitations: 'YES', 'NO'

**FREQ\_OUT** - option for writing the piping vibration eigen modes in a binary file with the for the subsequent view by means of the PIPE3DV program.

type: [TEXT](#)  
 unit: -  
 default value: 'YES'  
 limitations: 'YES', 'NO'

**ARC\_ANG** - minimum allowable angle for the [Bend \(2\)](#) element

type: [REAL](#)  
 unit: degrees  
 default value: [BEND\\_ANG](#)  
 limitations:  $> 0 ; \leq 10^0$

**RH\_STF** - stiffness to be used by default for rod hangers and for locked springs in the analysis for hydraulic tests (see also the TEST calculation type in the [SOLV](#) command)

type: [REAL](#)  
 unit: N/mm  
 default value:  $1 \cdot 10^5$   
 limitations:  $\geq 0$

**RH\_PEND** - a flag for the allowance of swing (pendulum) effect for rod hangers within the framework of dynamic analysis ([SOLV](#) command, [TYPE](#) = 'MODAL'). The load to be used for the computation of lateral stiffness of the hanger

shall be determined in the analysis, which number is indicated in the [PEND](#) parameter of the [SOLV](#) command.

type: [TEXT](#)  
 unit: -  
 default value: 'NO'  
 limitations: 'YES', 'NO'

**BEND\_ANG** - minimum permissible angle for the [Bend \(1\)](#) element

type: [REAL](#)  
 unit: degrees  
 default value: 5°  
 limitations: > 0 ; < 90°

**TBRC\_TOL** tolerance for the inclination of the branch from 90°

type: [REAL](#)  
 units: degrees  
 default value: 3°  
 limitations: ≥ 0 ; < 90°

**TRUN\_TOL** tolerance for the inclination of the run from 180°

type: [REAL](#)  
 units: degrees  
 default value: 3°  
 limitations: ≥ 0 ; < 90°

**RD\_WLD\_IV** - a flag of the allowance for the reduction coefficient of circumferential weld strength at the [verification calculation stage IV](#) (to be used only for [CODE](#) = 'RD')

type: [TEXT](#)  
 unit: -  
 default value: 'YES'  
 limitations: 'YES', 'NO'

**SPR\_SFPMIN** - safety coefficient relating to the minimum load. It is used at the selection of springs for spring supports/hangers. With the use of this coefficient, the following relationship shall be checked:  $Ph \cdot (1 - SPR\_SFPMIN \cdot (PFAC - 1)) \geq Pmin$

type: [REAL](#)  
 unit: -  
 default value: 1.0  
 limitations: 0.0 ÷ 1.0

**SPR\_VARTOL** - reference variability value for spring selection. When the condition [PVAR](#) < SPR\_VARTOL is met, the spring selection will stop even if the safety margin condition is not met.

type: [REAL](#)  
 unit: -  
 default value: 0.05  
 limitations: 0.0 ÷ 0.1

**SPR\_TRTRAV** - spring travel's computation method: SPR\_TRTRAV = 'YES' -> the spring travel shall be calculated with the account of horizontal deflection according to a "triangle"; SPR\_TRTRAV = 'NO' -> only deformation from vertical movement will be taken into account.

type: [TEXT](#)  
 unit: -  
 default value: 'NO'  
 limitations: 'YES', 'NO'

**SWING\_SH** - a flag of the allowance for swing effect for spring hangers ([SPR](#)): 'NO' - no account, 'YES' - to be taken into account without geometric non-linearity, 'GNL' - to be taken into account with the effect of geometric non-linearity.

type: [TEXT](#)  
 unit: -  
 default value: 'YES'  
 limitations: 'YES', 'NO', 'GNL'

**SWING\_RH** - a flag of the allowance for swing effect for rod hangers ([RH](#)): 'NO' - no account, 'YES' - to be taken into account without geometric non-linearity, 'GNL' - to be taken into account with the effect of geometric non-linearity.

type: [TEXT](#)  
 unit: -  
 default value: 'YES'  
 limitations: 'YES', 'NO', 'GNL'

**SWING\_ST** - a flag of the allowance for swing effect for rigid struts ([STRT](#)): 'NO' - no account, 'YES' - to be taken into account without geometric non-linearity, 'GNL' - to be taken into account with the effect of geometric non-linearity.

type: [TEXT](#)  
 unit: -  
 default value: 'YES'  
 limitations: 'YES', 'NO', 'GNL'

**TEE\_RD** Use of CKTI Engineering methodology for Stress Analysis of Tees and Branch Connections (only within 'RD' Code), See [Appendix XIII](#). Could be used only for "standard" tees.

type: [TEXT](#)  
 units: -  
 default value: 'CODE'  
 limitations: 'CODE', 'CKTI'

**TEE\_FLEX** option for the flexibility of tee/branch connection's joints (see [Appendix XIV](#)). Could be used only for "standard" tees (see [TEE](#)). Default value is 'CODE',

that means calculation of the tee's flexibility factor strictly according to the Code approach. 'NO' means ignoring of tee's flexibilities, even if they are required by CODE or defined in the input data. 'NB' means use of ASME BPVC NB-3600 approach for the branch connection's flexibility. 'PRG' prescribes use of the methodology proposed by Paulin Research Group (PRG), [REF 15]. Depending on used Strength Code this methodology is applied for the certain types of tee/branch connections. If CODE = 'PNAE'/'PNAE\_HT'/'RD', flexibility will be calculated for [BRC](#), [UFT](#) and [RFT](#) types. For other Codes methodology is acceptable for [WLT](#), [BRC](#), [UFT](#), [RFT](#), [EXT](#), [SQL](#), [WOL](#), [FWB](#) types. See also [Appendix XX](#)

type: [TEXT](#)  
 units: -  
 default value: 'CODE'  
 limitations: 'CODE', 'NO', 'NB', 'PRG'

**RD\_E0330** option to set allowable stresses  $\sigma_2$  category ([S2\\_NNUE](#), [S2\\_MRZ](#), [S2\\_PZ1](#), [S2\\_PZ2](#), [S2\\_HDR](#)) according to RD EO 1.1.2.05.0330-2012, [REF 16] document. Could be used only for PNAE analysis (CODE = 'PNAE').

type: [TEXT](#)  
 units: -  
 default value: "NO"  
 limitations: 'NO', 'YES'

**E\_MOD\_EN** option to account hot modulus for the allowable stress range  $f_a$ . Applicable for [CODE](#) = 'EN' and affects calculation of [SGM3](#) and [SGM4](#). If [E\\_MOD\\_EN](#) = 'YES',  $f_a$  is reduced on (Eh/Ec), if [E\\_MOD\\_EN](#) = 'NO',  $f_a$  keeps unchanged, but internal forces are scaled to cold modulus

type: [TEXT](#)  
 unit: -  
 default value: 'YES'  
 limitations: 'YES', 'NO'

**NC\_SEISM** number of equivalent seismic cycles

type: [INTEGER](#)  
 unit: -  
 default value: 50  
 limitations: > 0

**SH\_LOAD** Flag used to define that presetting load for spring hangers/supports is defined as [R0](#). In this case, the program does not check the presetting load values ([P](#)) against the [PMAX](#) and [PMIN](#) parameters. When performing a calculation with data, the first load case has to be LC with type [OPER\\_R](#)

type: [TEXT](#)  
 unit: -  
 default value: -  
 limitations: 'R0'

**EN\_CORR** option for accounting of the corrosion in pipes for calculation of [SGM1](#), [SGM1T](#) и [SGM2](#) stresses ([CODE](#) = 'EN', [CODE\\_YEAR](#) = '2020').

type: [TEXT](#)  
 unit: -  
 default value: see [Default values](#) Table  
 limitations: 'YES', 'NO'

Default values for control parameters depending upon strength analysis codes.

Parameter	Analysis codes							
	PNAE	PNAE_T	RD	ASME_NB	ASME_NC	EN	ASME_B311	ASME_B314
<a href="#">NC</a>	3000	3000	3000	7000	7000	7000	7000	7000
<a href="#">BEND_CODE</a>	PNAE/RD	PNAE/RD	PNAE/RD	ASME	ASME	ASME	ASME	ASME
<a href="#">BEND_PRES</a>	YES	YES	YES	YES	NO	NO	NO	NO
<a href="#">E_MOD</a>	HOT	HOT	HOT	HOT	REF	HOT	REF	REF
<a href="#">OVAL(3)</a>	-	-	1,0,1	-	-	-	-	-
<a href="#">KS</a>	-	-	1.4	-	-	-	-	-
<a href="#">WLD_CHK</a>	-	YES	YES	-	-	-	YES	-
<a href="#">HI_E</a>	-	0.6	-	-	-	-	-	-
<a href="#">SN_T</a>	-	NO	-	-	-	-	-	-
<a href="#">PNAE_KE</a>	NO	-	-	-	-	-	-	-
<a href="#">K_OL</a>	-	-	-	-	-	1	1.15	-
<a href="#">BEND_PST_R</a>	-	-	-	-	-	NO	NO	-
<a href="#">WLD_SUST</a>	-	-	-	-	-	-	NO	-
<a href="#">SL_PRES</a>	-	-	-	-	-	-	1	-
<a href="#">SA_LBRL</a>	-	-	-	-	-	-	NO	-
<a href="#">BRN_RUN</a>	-	-	0.77	-	-	-	1	-
<a href="#">SH_140</a>	-	-	-	-	-	-	YES	-
<a href="#">RD_WLD_IV</a>	-	-	YES	-	-	-	-	-
<a href="#">CODE_YEAR</a>	1989	1989	2001	1992	1992	2012	2008	2006
<a href="#">TEE_RD</a>	-	-	CODE	-	-	-	-	-
<a href="#">TEE_FLEX</a>	CODE	CODE	CODE	CODE	CODE	CODE	CODE	CODE
<a href="#">RD_E0330</a>	NO	-	-	-	-	-	-	-
<a href="#">E_MOD_EN</a>	-	-	-	-	-	YES	-	-
<a href="#">EN_CORR<sup>1)</sup></a>	-	-	-	-	-	NO	-	-

Note:

<sup>1)</sup> This option is available only for stress analysis according to EN Code, Edition 2020

Example :

CTRL TA 50 NC 1000

## Fatigue Data (FAT)

**type:** general multi-line command

**Function:** input of the fatigue curves

### Parameters:

**ID** - identification name of the fatigue curve

type:	<a href="#">TEXT</a>
unit:	-
default value:	-
limitations:	see limitations for the text values of parameters

**EM**<sup>1)</sup> - Young Modulus used to develop the Calculational Fatigue Curve from the measured strains to the conditionally elastic stresses .

type:	<a href="#">REAL</a>
unit:	N/mm <sup>2</sup>
default value:	modulus of elasticity at the <a href="#">T_REF</a> temperature (see CTRL command)
limitations:	> 0

**INT** - identifier of the interpolation method for intermediate points. Depending upon the INT value, the interpolation will be carried out either along the linear or logarithmic scale of the fatigue curve axes.

type:	<a href="#">INTEGER</a>
unit:	-
default value:	11
limitations:	0 (LIN-LIN); 1(LOG-LIN); 10(LIN-LOG); 11(LOG-LOG)

### Parameter subcommands

**NC** - array of the numbers of cycles for the fatigue curve being entered

type:	<a href="#">INTEGER</a>
unit:	-
dimension:	array from 1 to 32 elements
default value:	-
limitations:	from 1 to $1 \cdot 10^{12}$ . Each subsequent element of the array shall be larger than the previous one. It is allowed to enter an integer number of cycles in the exponential form

**SA** - array of the values of amplitudes of conditional elastic stresses corresponding to the numbers of cycles being entered.

type:	<a href="#">REAL</a>
unit:	MPa

Dimension: array from 1 to 32 elements  
 default value: -  
 limitations: > 0. Each subsequent element of the array shall not be larger than the previous one.

**Note:**

1) In computation of  $(\sigma_{aF})_K$  stresses, the design stress value shall be multiplied by the value of  $(E_m/E_{ref})$  in accordance with Item 5.6.5 of the Codes [REF 1] where  $E_{ref}$  is the modulus of elasticity at the  $T_{REF}$  temperature (see CTRL command).

Example:

```
FAT ID 'AUS' E 1.75E5 INT 11
& NC 10 20 50 100 200 500 850 1000 \
    2000 5000 10000 12000 20000 50000 100000 200000 5. E 5 1. E 6

& SA 3194 2307 1519 1123 842 593 493 468 \
    379 297 234 221 189 150 130 116 104 98
```

**Creep Data (CREEP)**

**type:** general multi-line command

**Function:** input the set of curves for high-temperature piping system analysis (to be used at [CODE='RD'](#) or [CODE='PNAE\\_T'](#)).

**Parameters:**

**ID** - identification name.

type: [TEXT](#)  
 unit: -  
 default value: -  
 limitations: see limitations for the text values of parameters

**T0** - initial temperature, above which the piping system is considered as high-temperature one (see Item 5.2.1.2 of RD 10-249-98 [REF 2]).

type: [REAL](#)  
 unit: °C  
 default value: 370  
 limitations: > 0.

**Parameter subcommands:**

**T** - array of temperatures, for which the data are set.

type: [REAL](#), array from 1 to 32 elements  
 unit: °C  
 default value: -  
 limitations: Each subsequent element of the array shall be larger than the previous one

**HI** - array of values of the coefficients of averaging of secondary (thermal) stresses depending upon working temperature (see Fig. 5.5 of RD 10-249-98 [\[REF 2\]](#)).

type: [REAL](#)  
 unit: -  
 dimension: array from 1 to 32 elements  
 default value: -  
 limitations:  $0 < Hi \leq 1$ .

**DELTA** - array of values of the coefficients of relaxation of secondary (thermal) stresses depending upon working temperature (see Fig. 5.6 of RD 10-249-98 [\[REF 2\]](#)).

type: [REAL](#)  
 unit: -  
 dimension: array from 1 to 32 elements  
 default value: -  
 limitations:  $0 < DELTA \leq 1$

Example :

```

CREEP ID '1' T0 370
& T = 370 380 390 400 410 420 430 440 450
460 470
& HI = 0.59 0.58 0.57 0.56 0.55 0.55 0.53 0.51 0.50
0.48 0.45
& T = 370 380 390 400 410 420 430 440 450
460 470
& DELTA = 0.76 0.77 0.78 0.79 0.81 0.83 0.85 0.87 0.89
0.92 0.94

```

## Materials (MAT)

The screenshot shows a software window titled "Materials. Code: EN". At the top, there is a table with columns "Name", "Density", and "Mu". Below this are five sub-tables, each with its own header and data rows. The sub-tables are:

- Table 1:** Columns T, E. Data rows: (1, -50, 207250), (2, 20, 202350), (3, 50, 200670), (4, 100, 198000), (5, 150, 195000), (6, 200, 192000), (7, 250, 189000), (8, 300, 185000), (9, 350, 179000), (10, empty).
- Table 2:** Columns T, A. Data rows: (1, -50, 1.11E-005), (2, 20, 1.16E-005), (3, 50, 1.18E-005), (4, 100, 1.21E-005), (5, 150, 1.24E-005), (6, 200, 1.27E-005), (7, 250, 1.3E-005), (8, 300, 1.33E-005), (9, 350, 1.36E-005), (10, empty).
- Table 3:** Columns T, Su, Sy. Data rows: (1, -50, 360, 225), (2, 20, 360, 225), (3, 50, 360, 214.875), (4, 100, 360, 198), (5, 150, 360, 187), (6, 200, 360, 170), (7, 250, 360, 150), (8, 300, 360, 132), (9, 350, 360, 120), (10, empty).
- Table 4:** Columns T, Sa. Data rows: (1, -50, 150), (2, 20, 150), (3, 50, 143.25), (4, 100, 132), (5, 150, 124.66), (6, 200, 113.33), (7, 250, 100), (8, 300, 88), (9, 350, 80), (10, empty).
- Table 5:** Columns T, St. Data rows: (1, -50, 150), (2, 20, 150), (3, 50, 143.25), (4, 100, 132), (5, empty), (6, empty), (7, empty), (8, empty), (9, empty), (10, empty).

**type:** general multi-line command

**Function:** determination of piping material properties

**Parameters:**

**ID** - identification name of the material

type: [TEXT](#)  
 unit: -  
 default value: -  
 limitations: see limitations for the text values of parameters

**FAT** - reference identification name of the fatigue curve (see FAT command)

type: [TEXT](#)  
 unit: -  
 default value: -  
 limitations: see limitations for the text values of parameters

**FAT \_ B** - reference identification name of the fatigue curve for bend (see FAT command)

type: [TEXT](#)  
 unit: -  
 default value: -  
 limitations: see limitations for the text values of parameters. It is used for checking the piping system strength according to RD 10-249-98 code [\[REF 2\]](#)

**CREEP** reference identification name of the creep curve

type: [TEXT](#)  
 unit: -  
 default value: -  
 limitations: see limitations for the text values of parameters.

**DEN** - density of the material

type: [REAL](#)  
 unit: in fractions of the water density (for water DEN = 1)  
 default value: 7.85  
 limitations: > 0.

**MU** -Poisson's ratio

type: [REAL](#)  
 unit: -  
 default value: 0.3  
 limitations:  $0 \leq \text{MU} \leq 0.5$

**M, N** - parameters of the material to be used for simplified elastic-plastic analysis (to be taken into account only for [CODE](#)='ASME\_NB' or [CODE](#)='PNAE'). It is recommended to determine then according to the NB-3228.5(b)-1 table [[REF\\_3](#), [REF\\_11](#)].

type: [REAL](#)  
 unit: -  
 default value: 0, 0  
 limitations:  $\geq 0$

<b>Table XIII-3450-1</b>			
<b>Values of <math>m</math>, <math>n</math>, and <math>T_{\max}</math> for Various Classes of Permitted Materials</b>			
Materials	$m$	$n$	$T_{\max}$ , °F (°C)
Carbon steel	3.0	0.2	700 (370)
Low alloy steel	2.0	0.2	700 (370)
Martensitic stainless steel	2.0	0.2	700 (370)
Austenitic stainless steel	1.7	0.3	800 (425)
Nickel-chromium-iron	1.7	0.3	800 (425)
Nickel-copper	1.7	0.3	800 (425)

GENERAL NOTE:  $T_{\max}$  is the maximum metal temperature.

**JF** - weld joint efficiency factor, ASME B31.1 [[REF\\_12](#)]). This factor is used for the conversion of allowable stresses entered from Appendix A. It is used when [CODE](#) = 'ASME\_B311'

type: [REAL](#)  
 unit: -  
 default value: 0.3  
 limitations:  $0 < \text{JF} \leq 1$

**TYPE** - type of material. Is used when [CODE](#) = 'PNAE', [CODE\\_YEAR](#) = 2022 are applied. Parameter defines the type of material: 'CS' – carbon steels, 'CMS' - alloyed chromium molybdenum and chromium molybdenum vanadium steels, 'AUS' – stainless austenitic steels. This parameter is used for fatigue analysis: calculation of allowable number of cycles considering environmental effects (Appendix B of Code [\[24\]](#))

type:	<a href="#">TEXT</a>
unit:	-
default value:	-
limitations:	'AUS', 'CS', 'CMV'

### Parameter subcommands

**T** - array of temperatures, for which the characteristics of the material are determined.

type:	<a href="#">REAL</a> , array from 1 to 32 elements
unit:	°C
default value:	-
limitations:	Each subsequent element of the array shall be larger than the previous one.

**E** - modulus of elasticity

type:	<a href="#">REAL</a> , array from 2 to 32 elements
unit:	MPa
default value:	-
limitations:	> 0.

**A** - average temperature linear expansion coefficient

type:	<a href="#">REAL</a> , array from 2 to 32 elements
unit:	1/°C
default value:	-
limitations:	> 0.

**SU** - ultimate strength

type:	<a href="#">REAL</a> , array from 2 to 32 elements
unit:	MPa
default value:	-
limitations:	> 0.

**SY** - yield strength

type:	<a href="#">REAL</a> , array from 2 to 32 elements
unit:	MPa
default value:	-
limitations:	> 0.

**SA<sup>3)</sup>** - allowable stresses

type: [REAL](#), array from 1 to 32 elements  
 unit: MPa  
 default value: -  
 limitations: > 0.

**SOL<sup>2)</sup>** - allowable stresses for occasional loads (for example, seismic, wind, hydraulic shock).

type: [REAL](#), array from 1 to 32 elements  
 unit: MPa  
 default value: SA  
 limitations: > 0.

**SR<sup>3)</sup>** - creep-rupture strength

type: [REAL](#), array from 1 to 32 elements  
 unit: MPa  
 default value: -  
 limitations: > 0.

**ST** allowable stress under the proof test conditions

type: [REAL](#), array from 1 to 32 elements  
 units: MPa  
 default value: -  
 limitations: > 0.

**WLD** - reduction coefficients of weld joint strength

type: [REAL](#), array from 1 to 32 elements  
 unit: -  
 default value: -  
 limitations:  $0.5 < WLD \leq 1$

**Z** relative reduction of the sample cross-section at static fracture under tension, %

type: [REAL](#), array from 1 to 32 elements  
 unit: %  
 default value: -  
 limitations:  $100 > Z > 0$

**Note:**

1) It is recommended to use the SOL subcommand for high-temperature piping systems in order to re-determine the SA ( $[\sigma]$ ) value taken according to the 2.1 – 2.7 Table RD 10-249-98 [\[REF 2\]](#) and limited for high temperatures by the creep-rupture strength. As the current RD edition does not contain any direct instructions on the computation of nominal allowable stresses for occasional loads, it is recommended to use the following approach, which is similar to the procedure recommended by the American codes - ASME B31.3 [\[REF 8\]](#):

at  $T \leq T_s$ ,  $SOL = SA$

at  $T > T_e$ ,  $Sol = 0.8 * (Syt/1.5)$ ,

where

$T$  – working temperature, °C;

$T_e$  – temperature corresponding to the "high-temperature piping system" definition (Item 5.2.1.2 of RD), °C;

$Syt$  – yield strength of the material at the working temperature, MPa.

The reduction coefficient 0.8 is to be entered in the last formula for taking account of the material aging effect at high temperatures.

For materials included into the database, which is supplied along with the program (MAT.DBS file), the SOL values have been determined on the basis of yield strength values taken from [REF 9]

The allowable stresses SOL are used at the comparison of stress values  $S_I\_PZ$  (POST command): the strength condition will be met if  $S_I\_PZ \leq 1.8 * SOL$

2) The MAT command parameters are used by the program depending upon the strength analysis codes in accordance with the following table:

CODE	ID	FAT	FAT_B	CREEP	DE	M	M	M	TYP	JF	E	A	SU	SY	SA	SO	SR	WL	ST	Z
PNAE	x	x			x	x	x				x	x	x	x						
PNAE 2022	x	x			x	x	x	x			x	x	x	x						x
PNAE_T	x	x		x	x	x	x				x	x	x	x			x			
RD	x	x	x	x	x	x					x	x			x	x				
EN	x				x	x					x	x	x	x	x	x	x		x	
NC	x				x	x					x	x	x	x	x					
NB	x	x			x	x	x				x	x	x	x	x					
B311	x				x	x				x	x	x	x	x	x			x		
B314	x				x	x					x	x			x					

3) Parameters SA & SR may be entered as functions of lifetime (in thousands hours) depending on used CODE:

CODE	SA[TAU]	SR[TAU]
RD	+	-
EN	-	+
PNAE_T	-	+

The following syntax is used in this case: : SA[TAU]/SR[TAU], where TAU is lifetime:

```
& T          -20  20 150 250 300 350 400 420 440 450 460 480 500 510 520 530 540 550 560 570 580
& SA[10]     173  173 173 166 159 152 145 142 139 138 136 133 130 120 112 100 88  80  72  65  59
& SA[100]    173  173 173 166 159 152 145 142 139 138 136 133 113 101  90  81  73  66  59  53  47
& SA[200]    173  173 173 166 159 152 145 142 139 138 136 120  96  86  77  69  62  56  50  44  39
```

Example :

```
MAT 'ST20' FAT 'CS' DEN 7.8 MU 0.3
& T = 20 50 100 150 200 250 300 350
& SU = 402.00 392.00 392.00 392.00 373.00 373.00 363.00 353.00
& SY = 216.00 206.00 206.00 206.00 196.00 196.00 177.00 157.00
& E = 2.000E+05 1.970E+05 1.950E+05 1.920E+05 1.900E+05 1.850E+05
1.800E+05 1.750E+05
& A = 1.150E-05 1.150E-05 1.190E-05 1.220E-05 1.250E-05 1.280E-05
1.310E-05 1.340E-05
```

## Pipe cross-section (PIPE)

Pipe Sections. Code: RD										
	Name	Diameter	Wall Thickness	Weight of pipe	C	Material	FW1	FW2	Insulation Weight	Corrosion
✓	1 CS225C	273	20	1.333	1	\$15GS	1	0.9	0.3	1
	2 CS175C	219	16	0.856	0.8	\$15GS	1	0.9	0.25	1

Std. bend	<b>BEND</b> Name	<b>R</b> Radius	<b>OVAL</b> Out-of-round.	Smin	<b>CROS</b> Section
1	LR	1370	7	14.7	CS225C
2	SR	375	7	15.5	CS225C

**type:** general multi-line command

**Function:** determination of the characteristics of piping system cross-sections

### Parameters:

**ID** - identification name of the cross-section

type: [TEXT](#)  
 unit: -  
 default value: -  
 limitations: see limitations for the text values of parameters

**OD** - outside diameter

type: [REAL](#)  
 unit: mm  
 default value: -  
 limitations: > 0

**T** - nominal wall thickness of the pipe

type: [REAL](#)  
 unit: mm  
 default value: -  
 limitations:  $0 < T < OD/2$

**W<sub>D</sub>** - weight per length

type: [REAL](#)  
 unit: N/mm  
 default value:  $\pi * (OD - T) * T * DEN * W\_DEN$

limitations:  $\geq 0$

**C<sup>2)</sup>** - mill tolerance

type: [REAL](#)  
 unit: mm or %  
 default value: 0  
 limitations: if  $C > 0$ , then  $T - C > 0$ ,  
 if  $C < 0$ , then  $|C| < 100$ .

**MAT** - reference identification name of the material (see [MAT](#) command)

type: [TEXT](#)  
 unit: -  
 default value: -  
 limitations: the name should coincide with the materials names determined earlier.

**FW(2)<sup>3)</sup>** - reduction coefficients of weld strength. FW(1) – reduction coefficient of longitudinal (spiral) weld strength; FW(2) – reduction coefficient of circumferential weld strength;

type: [REAL](#)  
 unit: -  
 default value: 1, 1  
 limitations:  $0 < FW \leq 1$

**FI\_S** - cyclic strength reduction coefficient for welding connections (for [CODE](#) = 'PNAE' and 'PNAE\_T', it is to be set by the user in accordance with Item 5.6.12 of the codes [[REF 1](#)], see also the [WLD](#) command)

type: [REAL](#)  
 unit: -  
 default value: 1  
 limitations:  $0 < FI\_S \leq 1$

**IWGT<sup>4)</sup>** - insulation's weight per length

type: [REAL](#)  
 unit: N/mm  
 default value: 0  
 limitations:  $\geq 0$

**CORR** - corrosion allowance.

type: [REAL](#)  
 unit: mm  
 default value: 0  
 limitations:  $CORR \geq 0$   
 if  $C \geq 0$ , then  $T - (C + CORR) > 0$ ,  
 if  $C < 0$ , then  $T - (0.01 * |C| * T + CORR) > 0$

Subcommand: [BEND](#), [MITR](#), [JEE](#)

**Notes:**

- 1) See also [Appendix IV](#) for comments relating to the weight load setting for piping systems.
- 2) If the C parameter value is set < 0, then it is assumed that the reduction of the pipe wall thickness is set in percentage of the nominal piping wall thickness.
- 3) For piping systems to be analyzed according to the RD boiler codes and for high-temperature piping systems to be analyzed according to PNAE (CODE = 'RD', CODE = 'PNAE\_T'), there is an alternative form of setting the reduction coefficients of weld strength. Instead of FW(1) and FW(2) array elements, it is possible to determine the following two parameters: FW1 and FW2. The FW1 parameter is fully similar to the first element FW(1) of the array. The FW2 parameter is a text mark corresponding to the type of circumferential weld. For CODE = 'RD' the FW2 parameter can take the following values: 'CS' - carbon steels; 'AUS' - austenite steels; 'CMV' - chrome-molybdenum-vanadium steels (see Table 4.2 of RD). For PNAE codes, it is permitted to use only FW2 = 'CMV'. In using such a form, the program will automatically assign the reduction coefficients of circumferential welds depending upon the values entered and the working temperature of the piping system.

**Examples:**

```
PIPE 'A325x12' OD 325 T 12 W 0.9320 C -12.5 MAT '08H18N10T' ; Dy 300
&BEND 'LR' R 1000 OVAL 7 SMIN 7.3 CROS 'A325x12' XT 1.1
&BEND 'SR' R 550 OVAL 7 SMIN 7.0 CROS 'A325x12' ; 46-50 OCT 24.125.06-89 325x12
&MITR 'R124-15' R 124 NC 2 ANGLE 45 XM 1.3
&TEE 'BRC' BID 'A14x2' DB 21 TB 5.5 H 245 MAT '08H18N10T' ; 01 OCT 24.125.11-89
325x12 14x2
```

**Standard Bends (&BEND)**

**BEND** - identification name of the bend. It is used for "standard" bends assigned under the current cross-section.

type:	<a href="#">TEXT</a>
unit:	-
default value:	-
limitations:	see limitations for the text values of parameters

**Subcommand parameters:**

**R** - radius of the bend

type:	<a href="#">REAL</a>
unit:	mm
default value:	-
limitations:	> 0

**OVAL** - ovality (out-of-roundness) of the cross-section

type:	<a href="#">REAL</a>
unit:	%
default value:	0
limitations:	$0 \leq OVAL \leq 100$

**SMIN** - minimum wall thickness of the bend (with no account of the pipping wall thinning)

type:	<a href="#">REAL</a>
-------	----------------------

unit: mm  
 default value: T - C  
 limitations: (1)

**XT<sup>2</sup>** wall thickness correction factor

type: REAL  
 unit: -  
 default value: 1  
 limitations:  $\geq 1$

**CROS** - reference to the PIPE name determined earlier and being used for the bend cross-section characteristics

type: TEXT  
 unit: -  
 default value: 'ID' name of the main PIPE command  
 limitations: the name should coincide with the cross-section names determined earlier

**Notes:**

1) The stresses in the bends per PNAE or RD Code are calculated with use of  $SMIN^*$  value:

1) if  $smin > 0$

$$smin^* = smin - corr$$

2) if  $smin = 0$

$$smin^* = t - c^* - corr; \quad c^* = \begin{cases} c; & \text{if } c \geq 0 \\ t|c|/100; & \text{if } c < 0 \end{cases}$$

3) if  $smin < 0$

$$smin^* = (t - c^*)|smin|/100 - corr$$

The assignment  $smin < 0$  is suitable for modeling bends in which the  $smin$  value is normalized relative to the "actual wall thickness of the pipe", for example, STO 95 111-2013

2) When specifying elbows according to various domestic and international standards (GOST, STO, B16.9, EN), information about the average elbow thickness is often missing. To avoid introducing additional auxiliary cross-sections, the parameter  $xt$  - a wall thickness scaling factor can be used. In this case, the elbow will be modeled using a cross-section with the diameter ( $Do$ ) of the matched pipe and a wall thickness of  $te = xt \times t$ . The weight per length of such a cross-section will be determined by the formula:  $we = (Do/t - xt) \times xt \times w / (Do/t - 1)$ , where:  $Do$  - outside diameter of the matched pipe;  $t$  - wall thickness of the matched pipe;  $w$  - weight per length of the matched pipe.

**Standard Miter Bends (&MITR)**

**MITR** Identification name of the miter bend. Used to identify standard fittings compatible with the current PIPE.

type: TEXT  
 unit: -  
 default value: -  
 limitations: see limitations for the text values of parameters

**Subcommand parameters:**

**R** miter bend radius as defined in the drawing;

type:	<a href="#">REAL</a>
unit:	MM
default value:	-
limitations:	$R \geq r$ (mean pipe radius)

**NC** number of cuts

type:	<a href="#">INTEGER</a>
unit:	-
default value:	-
limitations:	$> 0$

**XM<sup>1)</sup>** weight correction factor;

type:	<a href="#">REAL</a>
unit:	-
default value:	1
limitations:	$\geq 1$

**ANGLE** miter bend angle (is used to check geometry of the piping layout)

type:	<a href="#">REAL</a>
unit:	degrees
default value:	0
limitations:	$\geq 0$

**CROS** reference to the PIPE name determined earlier and being used for the bend cross-section characteristics

type:	<a href="#">TEXT</a>
unit:	-
default value:	'ID' name of the main PIPE command
limitations:	the name should coincide with the cross-section names determined earlier

See also [Appendix XIX](#) on modeling miter bends in dPIPE

**Notes:**

- 1) *The weight of the miter bends according to the technical documentation may be 5% higher than the value calculated in the program. This discrepancy may arise if such a fitting is modeled by the miter bend itself and attached straight pipes. To specify the exact weight, the correction factor  $xm = (W - 2lw) / (R\alpha w)$  is used, where:  $W$  – elbow weight specified in the drawing;  $l$  – length of the straight sections;  $w$  – weight per length of the pipe from the current cross-section;  $R$  – radius of the miter bend (per drawing);  $\alpha$  – total elbow angle (in radians). This adjustment ensures accurate mass representation in the model.*

### Standard Tee Connections (&TEE)

**TEE** ID of the piping intersection. It's used to set input data for standard fittings adjacent to the matched pipes.

type: [TEXT](#)  
 unit: -  
 default value: -  
 limitations: see limitations for the text values of parameters

ID for "standard" fittings is composed as follows:  $TEE=TYPE[\$....]$ , where *TYPE* is predefined name that depends on used Code and can be set to one of the following values: [BRC](#), [WLT](#), [RFT](#), [UFT](#), [EXT](#), [SOL](#), [WOL](#), [FWB](#). Second part of the ID beginning from "\$" sign is optional. It's used to distinguish between several standard tees matched to the same pipe sizes but having different parameters. For example: &TEE 'BWT' ...; &TEE 'BWT\$01' ...; &TEE 'BRC' .... For Russian Codes (CODE = 'PNAE', 'PNAE\_HT' and 'RD') any ID can be used.

**Subcommand parameters:**

**Main parameters (applicable for all Codes):**

**BID** ID of the BRANCH pipe, required parameter, should refer to the existing command PIPE

type: [TEXT](#)  
 units: -  
 default value: -

limitations: only sections previously set by PIPE command

**DR, TR** outer diameter and wall thickness of the RUN pipe

type: [REAL](#)  
 units: mm  
 default values: corresponding data of the matched "parent" PIPE  
 limitations: > 0

**DB, TB** outer diameter and wall thickness of the BRANCH pipe

type: [REAL](#)  
 units: mm  
 default values: corresponding data of the BRANCH pipe defined by **BID** name  
 limitations: > 0

**L** length of the body. If **DR, TR** are set explicitly, **L** is required .

type: [REAL](#)  
 units: mm  
 default values: -  
 limitations: > 0, length of any adjacent elements should not be greater than L/2

**H** height of branch (measured from the run pipe axis line) . If **DB, TB** are set explicitly, **H** is required.

type: [REAL](#)  
 units: MM  
 default values: -  
 limitations: > 0, length of any adjacent elements should not be greater than H

**W** weight of the fitting

type: [REAL](#)  
 units: N  
 default values: If H or L are set, then:  $W = w_r * L + w_b * (H - DR/2)$ , where:  $w_r = \text{MAX}(\pi * (DR - TR) * TR * \text{DEN}; w_{rp})$ ;  $w_{rp}$  – weight per length for adjacent RUN pipe; DEN – density of the material MAT;  $w_b = \text{MAX}(\pi * (DB - TB) * TB * \text{DEN}; w_{bp})$ , where:  $w_{bp}$  - weight per length for adjacent BRANCH pipe (BID);  
 limitations:  $\geq 0$

**MAT** reference name of the fitting's material (see command [MAT](#))

type: [TEXT](#)  
 units: -  
 default values: material of the RUN adjacent pipe  
 limitations: name should be defined by command [MAT](#)

**FLEX(4)** flexibility factors: FLEX(1) – in plane bending ( $k_{ib}$ ), FLEX(2) – out of plane bending ( $k_{ob}$ ), FLEX(3) – torsion of the branch ( $k_{tb}$ ), FLEX(4) – axial branch's flexibility ( $k_a$ )

type: [REAL](#)

units: -

dimension: 4-elements array

default values: are set in accordance with [TEE\\_FLEX](#) parameter. If one of the elements = 0, then flexibility in this direction is not considered despite the [TEE\\_FLEX](#) parameter.

limitations:  $\geq 0$

**Additional parameters (are compatible only with certain types of tees, depending on the used stress Codes), see also [Appendix XX](#):**

The screenshot shows a dialog box titled "Standard Tee" with a close button (X) in the top right corner. It has two tabs: "General" and "Advanced". The "General" tab is active and contains the following parameters and input fields:

R2	Rp	Rx
<input type="text" value="400"/>	<input type="text"/>	<input type="text"/>
Ta	Tc	Tn
<input type="text"/>	<input type="text"/>	<input type="text"/>
Tp	Tw	Cr
<input type="text"/>	<input type="text"/>	<input type="text"/>
Cb	Kis	
<input type="text"/>	<input type="text"/>	

At the bottom of the dialog box, there are three buttons: "OK", "Cancel", and "Help".

Type of the tee is defined by its identification name [identification name](#). See also [Appendix XIV](#)

### Beam cross-section (BEAM)

type: general one-line command

**Function:** determination of the characteristics of beam element cross-sections

**Parameters:**

**ID** - identification name of the cross-section

type:	<a href="#">TEXT</a>
unit:	-
default value:	-
limitations:	see limitations for the text values of parameters

**AX** - cross-sectional area

type:	<a href="#">REAL</a>
unit:	mm <sup>2</sup>
default value:	-
limitations:	> 0

**SY<sup>2</sup>** - shear shape factor along Y axis (at SY = 0, no shear is taken into account)

type:	<a href="#">REAL</a>
unit:	-
default value:	0
limitations:	≥ 0

**SZ<sup>2</sup>** - shear shape factor along Z axis (at SZ = 0, no shear is taken into account)

type:	<a href="#">REAL</a>
unit:	-
default value:	0
limitations:	≥ 0

**IX** - torsional moment of inertia

type:	<a href="#">REAL</a>
unit:	mm <sup>4</sup>
default value:	-
limitations:	> 0

**IY** - cross-section moment of inertia in respect to Y axis

type:	<a href="#">REAL</a>
unit:	mm <sup>4</sup>
default value:	-
limitations:	> 0

**IZ** - cross-section moment of inertia in respect to Z axis

type:	<a href="#">REAL</a>
-------	----------------------

unit: mm<sup>4</sup>  
 default value: -  
 limitations: > 0

**W**<sup>3)</sup> - weight per length

type: [REAL](#)  
 unit: N/mm  
 default value: 0  
 limitations: ≥ 0

**MAT** - reference identification name of the material (see [MAT](#) command)

type: [TEXT](#)  
 unit: -  
 default value: -  
 limitations: the name should coincide with the names of materials determined earlier

**B** - cross-section width - the size along the local Y axis (for displaying in 3D mode)

type: [REAL](#)  
 unit: mm  
 default value: 0  
 limitations: ≥ 0

**H** - cross-section height - the size along the local Z axis (for displaying in 3D mode)

type: [REAL](#)  
 unit: mm  
 default value: 0  
 limitations: ≥ 0

**TYPE** - cross-section type (for displaying in Pipe3DV)

type: [TEXT](#)  
 unit: -  
 default value: 'I'  
 limitations: 'I', 'U', 'L', 'P', 'B', 'O', 'T'

'I' - I-beam; 'U' - channel; 'L' - angle; 'P' - rectangular pipe; 'B' - rectangular solid cross-section; 'O' - circular solid cross-section; 'T' - T-section

**Note:**

- 1) The geometric characteristics of beam element cross-sections are determined in the local coordinate system (see [Appendix I](#)).
- 2) Shear in beams becomes available if "shear shape factors" (Sy and Sz parameters) are set as non zero values. Typical values of shear shape factors ( $\mu$ ) are shown below:

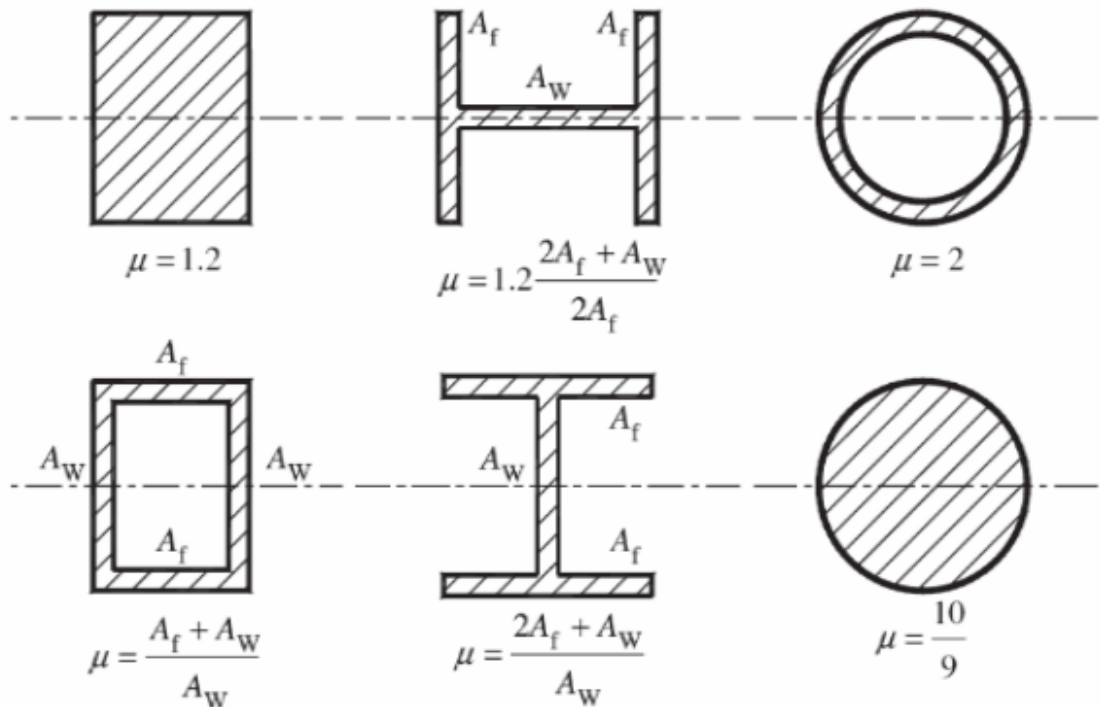

3) See also [Appendix IV](#) for comments relating to the weight load setting.

Example :

```
BEAM 'BEAM1' AX 6.40000E+03 IX 5.76000E+06 IY 3.41000E+06 \
IZ 3.41000E+06 SY 1.200 SZ 1.200 \
W 0.0 MAT '08H18N10T' B 100 H 200 type = 'L'
```

## Operating modes (OPVAL)

**type:** general multi-line command

**Function:** setting the operating parameters of the piping system and its operating modes

**Parameters:**

**ID**<sup>1)</sup> - identification name of the piping system operating mode

type:	<a href="#">TEXT</a>
unit:	-
default value:	-
limitations:	see limitations for the text values of parameters

**TAU**<sup>4)</sup> - lifetime

type:	<a href="#">REAL</a>
-------	----------------------

unit:	thous. hours
default value:	200.
limitations:	$\geq 0$

### Parameter subcommand

**LG<sup>2)</sup>** - name of the piping system load group, i.e. the group of elements with the same working parameters

type:	<a href="#">TEXT</a>
unit:	-
default value:	-
limitations:	see limitations for the text values of parameters

### Subcommand parameters:

**P** - internal pressure

type:	<a href="#">REAL</a>
unit:	MPa
default value:	0
limitations:	$\geq 0$

**T** - temperature

type:	<a href="#">REAL</a>
unit:	°C
default value:	TA (see <a href="#">CTRL</a> command)
limitations:	-

**CSG<sup>3)</sup>** - content specific gravity (CSG = 0 - empty pipe, CSG=1.0 pipe with water)

type:	<a href="#">REAL</a>
unit:	in fractions of the water density (for water DEN = 1)
default value:	0
limitations:	$\geq 0$

**INS<sup>3)</sup>** - option for insulation

type:	<a href="#">REAL</a>
unit:	in fractions of the insulation weight assigned for the pipe section (see parameter IWGHT, Command PIPE)
default value:	1
limitations:	$\geq 0$

**TAU<sup>4)</sup>** - lifetime

type:	<a href="#">REAL</a>
unit:	thous. hours
default value:	<a href="#">TAU</a> (see above)
limitations:	$\geq 0$ .

### Note:

- 1) It's assumed that first operating mode described by this command corresponds to the Normal Operating Conditions (NOC). It could be mentioned as alias "**\$OPER**" in the parameter MOD, command [SOLV](#). A similar reference to the mode named **\$COLD** means using the cold state in the analysis: i.e. parameters of piping before startup: no medium, no pressure and at temperature  $T = TA$  (the mode with this name can be skipped in the command: the program will automatically determine its parameters). Other standard names are: **'TEST'** – for the regime of hydraulic tests with locked springs, **'\$INST'** – for the mode of piping installation and assembling (to redefine value of [TA](#) temperature); **\$DESIGN** and **\$PEAK** are used to define the design and peak pressure respectively within the analysis according to ASME BPVC.
- 2) Depending upon the working parameters (temperature, pressure, working fluid, insulation) the piping model is broken down into load groups. Each operating mode shall have a description of parameters for all load groups being present in the analysis model.
- 3) See also [Appendix IV](#) for comments relating to setting the weight load for piping elements.
- 4) Lifetime [TAU](#) is used for calculations according to [CODE](#) = 'RD', 'EN' and 'PNAE\_T'. Depending on this number the following parameters are calculated: allowable stresses [SA](#) or creep rupture strength [SR](#). If  $TAU = 0$ , then stresses which values are dependent on lifetime: [S\\_II](#), [S\\_IV](#)(CODE = 'RD') & [SGM5](#) (CODE= 'EN') will be skipped from calculations.

Example:

```
OPVAL 'NOL'
& 'Line_1' P 12.0 T 250 CSG 1
& 'Line_2' P 8.0 T 350 CSG 0
```

```
OPVAL 'ZERO'
& 'Line_1' P 0 T 20 CSG 1
& 'Line_2' P 0 T 20 CSG 0
```

## Discont. stresses due to temp. gradient and stratification (GRAD)

**type:** general multi-line command

**Function:** setting the parameters for taking into account of additional stresses from the temperature drop over the wall thickness as well as from the stratification effect (they are used in the analysis according to the PNAE codes [[REF 1](#)] and ASME BPVC NB-3600 (Class1) codes [[REF 3](#)]). The command shall be placed only after the [OPVAL](#) command. The *MODE* and *LG* parameters shall conform to the similar parameters defined in the [OPVAL](#) command.

### Parameters:

**MODE** - identification name of the piping system operating mode.

type:	<a href="#">TEXT</a>
unit:	-
default value:	-
limitations:	see limitations for the text values of parameters

### Parameter subcommand

**LG** - name of the load group of the piping system, i.e. the group of elements with the same working parameters

type:	<a href="#">TEXT</a>
unit:	-
default value:	-
limitations:	see limitations for the text values of parameters

**Subcommand parameters:**

**DT1** - linear part of the temperature gradient over the wall thickness

type:	<a href="#">REAL</a>
unit:	°C
default value:	0
limitations:	-

**DT2** - non-linear part of the temperature gradient over the wall thickness

type:	<a href="#">REAL</a>
unit:	°C
default value:	0
limitations:	-

**STRAT** - linear part of the temperature gradient over the cross-section height due to the stratification effect

type:	<a href="#">REAL</a>
unit:	°C
default value:	0
limitations:	-

**DT3** - non-linear part of the temperature gradient over the cross-section height due to the stratification effect

type:	<a href="#">REAL</a>
unit:	°C
default value:	0
limitations:	-

**STRESS** - pre-calculated stress from the temperature drop over the wall thickness

type:	<a href="#">REAL</a>
unit:	MPa
default value:	0
limitations:	-

**Example:**

```
GRAD 'MODE_2S'
& 'SECT_A'      DT1 0.2  DT2 0.03 STRESS 45 STRAT 27      DT3 10.04
& 'SECT_B'      DT1 2.8  DT2 0.5  STRESS 30 STRAT 20      DT3 6.6
```

```

& 'SECT_C_D'           DT1 0.2  DT2 0.03 STRESS 58 STRAT 19.17  DT3 14.1
& 'SECT_E'            DT1 0.2  DT2 0.03 STRESS 35 STRAT 29.42  DT3 7
& 'SECT_F'            DT1 0.2  DT2 0.03 STRESS 56 STRAT 21.67  DT3 13.38
& 'FW'                DT1 20.6 DT2 3.6  STRESS 34 STRAT 42.8   DT3 15
& 'FW_SG'             DT1 65.4 DT2 19.2 STRESS 34 STRAT 42.8   DT3 15

```

**Note:**

- 1) Depending upon the analysis codes selected, the program will use the following parameters: CODE = 'ASME\_NB':  $\Delta T_1$ ,  $\Delta T_2$ , STRAT and  $\Delta T_3$ ; CODE = 'PNAE' and CODE = 'PNAE\_T': STRESS, STRAT and  $\Delta T_3$ , the STRAT parameter can be used in the analysis according to any Codes.
- 2) The determination and methods of calculation of  $\Delta T_1$  and  $\Delta T_2$  are given in section NB-3653.2 [REF 3].
- 3) The STRESS parameter corresponds to the swing of full maximum temperature stress from the drop over the wall thickness |  
( $\sigma$ )<sub>T</sub>\* – see Item 2.3.3.4 of Appendix 5 of the PNAE codes [REF 1].
- 4) The determination and methods of calculation of STRAT and  $\Delta T_3$  are given in Appendix VIII.

Example:

```

OPVAL 'MODE_2S'
& 'SECT_A'           DT1 0.2  DT2 0.03 STRESS 45 STRAT 27      DT3 10.04
& 'SECT_B'           DT1 2.8  DT2 0.5  STRESS 30 STRAT 20      DT3 6.6
& 'SECT_C_D'         DT1 0.2  DT2 0.03 STRESS 58 STRAT 19.17  DT3 14.1
& 'SECT_E'           DT1 0.2  DT2 0.03 STRESS 35 STRAT 29.42  DT3 7
& 'SECT_F'           DT1 0.2  DT2 0.03 STRESS 56 STRAT 21.67  DT3 13.38
& 'FW'               DT1 20.6 DT2 3.6  STRESS 34 STRAT 42.8   DT3 15
& 'FW_SG'            DT1 65.4 DT2 19.2 STRESS 34 STRAT 42.8   DT3 15

```

**Water oxidation (ENVFAT)**

**type:** general multi-line command

**Function:** Defines the values of water oxidation for piping sections. The command is used in frame of the Environmental Fatigue Analysis according to GOST Code [REF 24], when the following parameters are set: **CODE** = 'GOST-59115-A', **FAT\_ENV** = 'YES'. The command must only come after the **OPVAL** command. The MODE and LG parameters must match those defined in the **OPVAL** command. The procedure for calculating fatigue curves according to GOST R 59115.9-2021, [REF 24] in the dPIPE program is described in Appendix XVII.

**Parameters:**

**MODE** identification name of the piping system operating mode.

type:	<a href="#">TEXT</a>
unit:	-
default value:	-
limitations:	see limitations for the text values of parameters

**Parameter subcommand**

**LG** name of the load group of the piping system, i.e. the group of elements with the same working parameters

type:	<a href="#">TEXT</a>
unit:	-
default value:	-
limitations:	see limitations for the text values of parameters

#### Subcommand parameters:

**KO** water oxidation

type:	<a href="#">REAL</a>
unit:	mg/kg
default value:	<a href="#">KO</a>
limitations:	$\geq 0$ .

#### Example:

```
ENVFAT mode = 'NUE'
& lg = 'LG1', ko = 0.3
ENVFAT mode = 'NNUE'
& lg = 'LG1', ko = 0.2
```

## Data for spring hangers and supports (SDEF)

**type:** general one-line command

**Function:** specification for the standard spring tables

#### Parameters:

**STAB** - identification name of the springs table

type:	<a href="#">TEXT</a>
unit:	-
default value:	'OST80'
limitations:	the corresponding parameters prescribed in the SH.DBS file (see <a href="#">Appendix VI</a> ), for example, 'MVN63', 'OST80', 'OST93', 'LISEGA')

**PVAR** - load variation coefficient

type:	<a href="#">REAL</a>
unit:	-
default value:	0.35
limitations:	$0 \leq PVAR \leq 1$

**PFAC** - load safety factor

type:	<a href="#">REAL</a>
unit:	-
default value:	1.3
limitations:	$\geq 1$

**ZMAX** - maximum structure of the chain

type:	<a href="#">INTEGER</a>
unit:	-
default value:	(2)
limitations:	$\geq 1$

**ZMIN** - minimum structure of the chain

type:	<a href="#">INTEGER</a>
unit:	-
default value:	1
limitations:	$1 \leq ZMIN \leq ZMAX$ ;

**Note:**

1) The SDEF command initiates the data to be used further by default in SPR commands by the characteristics of the hanger's/support's springs. One file with the input data can contain several SDEF commands.

2) By default, ZMAX is a maximal number of the working ranges predefined in the Manufacturer Catalogue (spring's table) being under consideration (see [Appendix VI](#))

Example:

```
SDEF 'OST93' PVAR 0.3 PFAC 1.4
SDEF 'LISEGA' PVAR 0.25 PFAC 1.1 ZMAX 3
```

## Seismic response spectra (SPEC)

**type:** general multi-line command

**Function:** setting the seismic input in terms of response spectra

**Parameters:**

**SET** The identification name of the spectra' set. For each set, separate SPEC commands are entered. SET is referenced in the command [DCASE](#) (parameter INP)

type:	<a href="#">TEXT</a> limited by four symbols
unit:	-
default value:	-
limitations:	see limitations for the text values of parameters

**GROUP** - identification name of the seismic group of supports. A separate SPEC command is entered for each group of supports.

type:	<a href="#">TEXT</a>
unit:	-
default value:	-
limitations:	see limitations for the text values of parameters

**INT** - identifier of the interpolation for intermediate points. Depending upon the INT value the interpolation is performed over either linear or logarithmic scale.

type: [INTEGER](#)  
 unit: -  
 default value: 0  
 limitations: 0 (LIN-LIN); 1 (LOG-LIN); 10 (LIN-LOG); 11 (LOG-LOG)

**MULT** - array of 3 numbers containing scaling factors for accelerations for each of the seismic excitation directions.

type: [REAL](#)  
 unit: -  
 default value: 1, 1, 1  
 limitations:  $\geq 0$

**DISP** - array of 3 numbers containing the components of seismic movements for the support group being specified.

type: [REAL](#)  
 unit: mm  
 default value: 0, 0, 0  
 limitations:  $\geq 0$

### Parameter subcommands

**FX, FY, FZ** - array of frequencies, for which the response accelerations are set along the corresponding direction: X, Y, Z

type: [REAL](#)  
 unit: Hz  
 dimension: array from 2 to 1000 elements  
 default value: -  
 limitations:  $> 0$ . Each subsequent element of the array shall be larger than the previous one.

**AX, AY, AZ** - array of response accelerations of seismic excitation along X, Y, Z directions

type: [REAL](#)  
**unit:** **g**  
 dimension: array from 2 to 1000 elements  
 default value: -  
 limitations:  $> 0$ .

Otherwise, it is possible to indicate the paths to files containing digital response spectrums in the form of the following commands:

```
SPEC group = '03_60', int = 0, mult = 0.049, 0.049, 0.049, disp = 0, 0,
0
& file_sx = ".\SPECTRA\03.60_Y_SSE.DAT"
& file_sy = ".\SPECTRA\03.60_X_SSE.DAT"
```

```
& file_sz = ".\SPECTRA\03.60_Z_SSE.DAT"
```

Example:

```
SPEC GROUP 'RB'   MULT = 1.00  1.00  1.00
&FX =  0.01  0.20  1.27  2.68  3.06  3.40  3.74  5.06
5.75 \
      6.09  7.22  9.77 10.35 11.53 15.60 19.55 21.27
35.80 57.50 \
      100.00
&AX =  0.054  0.054  0.420  0.900  1.142  1.897  2.067
2.067 \
      1.745  1.725  0.982  0.982  0.777  0.669  0.669
0.578  0.483 \
      0.445  0.362  0.362
&FY =  0.01  0.20  1.27  2.04  3.06  3.57  5.06  7.47
8.40 \
      9.35 12.00 18.00 23.00 57.50 100.00
&AY =  0.054  0.054  0.344  0.684  1.406  2.215  2.215
0.974 \
      0.860  0.627  0.963  0.963  0.625  0.417  0.417
&FZ =  0.01  0.20  1.19  2.69  3.57  5.50  6.80  9.20
9.77 \
      12.30 14.45 19.55 21.27 27.60 31.32 57.50 100.00
&AZ =  0.028  0.028  0.130  0.269  0.483  0.483  0.401
0.401 \
      0.452  0.488  0.677  0.677  0.487  0.449  0.255
0.140  0.140
```

## Seismic accelerograms (ACCE)

Interface for the input this data may be found in the ["Response Spectra/Accelerograms" window](#), tab "Accelerograms":

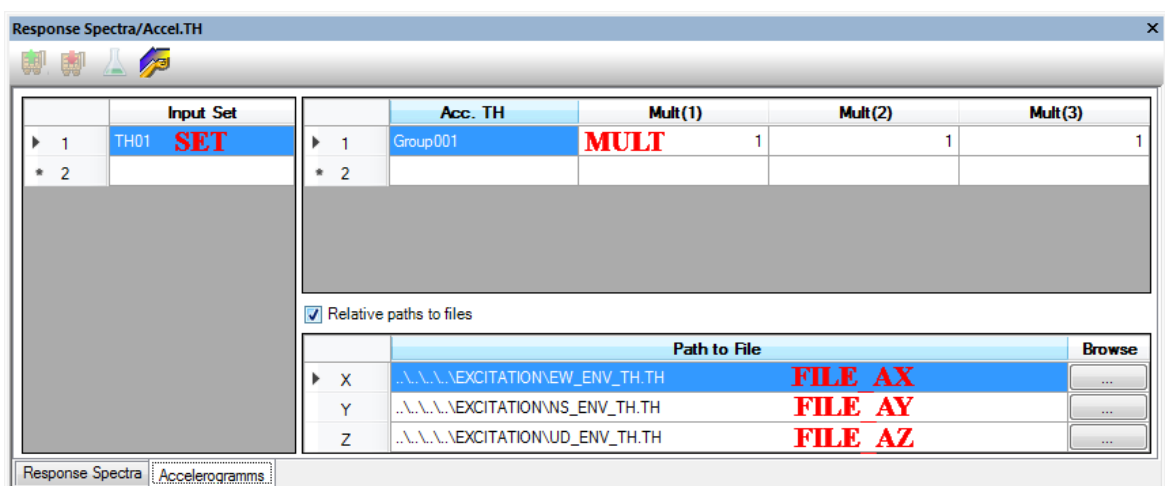

**type:** general multi-line command

**Function:** setting the seismic input in terms of accelerograms

**Parameters:**

**SET** The identification name of the acceleration time histories set. For each set, separate ACCE commands are entered. SET is referenced in the command [DCASE](#) (parameter INP)

type: [TEXT](#) limited by four symbols  
 unit: -  
 default value: -  
 limitations: see limitations for the text values of parameters

**MULT** **array of 3 numbers** containing scaling multipliers of accelerations for each of the seismic load direction

type: [REAL](#)  
 unit: -  
 default value: 1, 1, 1  
 limitations:  $\geq 0$

**Parameter subcommands**

**FILE\_AX**<sup>1)</sup> name of file containing digital accelerogram values<sup>2)</sup> for X direction

type: [STRING](#)  
 unit: -  
 default value: [blank](#)  
 limitations: see limitations for string values of parameters. The string length shall not exceed 128 characters.

**FILE\_AY** name of file containing digital accelerogram values for Y direction

type: [STRING](#)  
 unit: -  
 default value: [blank](#)  
 limitations: see limitations for string values of parameters. The string length shall not exceed 128 characters.

**FILE\_AZ** name of file containing digital accelerogram values for Z direction

type: [STRING](#)  
 unit: -  
 default value: [blank](#)  
 limitations: see limitations for string values of parameters. The string length shall not exceed 128 characters.

**Note:**

- 1) *If the file with digital accelerogram values is in the working directory, then it is sufficient to specify only its name with extension. In the remaining cases, it is required to specify the full path to the file.*
- 2) *In describing the accelerograms, the first line of the file shall contain 2 numbers: NT - number of accelerogram digitizing points and the DT - the value of the accelerogram digitizing step. Upon settings these values, the NT accelerogram digitizing points shall be specified in an*

arbitrary format. It should be noted that the step and number of digitizing points for all three accelerograms shall be identical. **The accelerations shall be specified in fractions of g!**

- 3) If analysis specification contains two or more dynamic load cases or several sets of dynamic excitations, to run [THA](#) considering seismic anchor movement, the names of the sets of accelerograms and response spectra must match

Example:

```
ACCE set = 'TH01', group = 'Group001', mult = 0.102, 0.102, 0.102
& file_ax = ".\ACC\OGIB_PND3_Y_k002_korr-acc.th"
& file_ay = ".\ACC\OGIB_PND3_X_k002_korr-acc.th"
& file_az = ".\ACC\OGIB_PND3_Z_k002_korr-acc.th"
```

## Specification for analysis (SOLV)

**type:** general multi-line command

**Function:** assignment of the sequence and parameters for the execution of individual stages of analysis

### Parameters:

<b>NAME</b>	name of analysis (description)
type:	<a href="#">STRING</a>
unit:	-
default value:	-
limitations:	see limitations for string values of parameters. The length shall not exceed 80 characters.

### Subcommand

**LC** specification for an individual analysis (Load Case)

### Subcommand parameters:

<b>TYPE</b>	type of analysis
type:	<a href="#">TEXT</a>
unit:	-
default value:	-
limitations:	the type of analysis shall either be specified (user type) or correspond to one of the following standard names: 'DSGN'; 'OPER_A'; 'OPER_B'; 'OPER_R'; 'SUST_A'; 'SUST_C'; 'MODAL'; 'TEST'; 'TEST_B'; 'SAM' (see Note 1)

**MOD** - identification name of the piping system operating mode

type:	<a href="#">TEXT</a>
unit:	-
default value:	-

limitations: see limitations for the text values of parameters. The operating mode shall preliminarily be described by the OPVAL command or corresponds to one of the following standard names: \$COLD – "cold" state: assumes empty pipeline at ambient temperature (T=TA, P = 0, CSG = 0); \$OPER – operating state corresponding to the first mode described by the [OPVAL](#) command (usually means Normal Operation of the system)

**LOAD**

set of loads

type: [TEXT](#)  
 unit: -  
 default value: -  
 limitations: see (2)

**PEND**(see also Note<sup>\*\*</sup>)

pendulum or swing effect option. Takes into account in spring and rod hangers

type: [TEXT](#)  
 unit: -  
 default value: 'NO'  
 limitations: 'YES', 'NO'

**FRIC**

support friction option

type: [TEXT](#)  
 unit: -  
 default value: 'NO'  
 limitations: 'YES', 'NO'

**NLS<sup>3)</sup>**

status of supports nonlinearities

type: [TEXT](#)  
 unit: -  
 default value: 'YES'  
 limitations: 'YES', 'REF', 'LIN'

**HNG\_STF** inclusion of stiffness from spring hangers in the general stiffness matrix

type: [TEXT](#)  
 unit: -  
 default value: 'YES'  
 limitations: 'YES', 'NO'

**PE**pressure elongation option (see [Appendix IX](#))

type: [TEXT](#)  
 unit: -  
 default value: 'NO'

limitations: 'YES', 'NO'

**NOTE** Note / Comment

type: [STRING](#)  
 unit: -  
 default value: [blank](#)  
 limitations: see limitations for string values of parameters

**Note:**

1) Standard types of Load Cases assume the certain interpretation for analysis options:

Type of analysis	Load from spring hangers/sup ports	inclusion the spring hangers stiffness in the global stiffness matrix	Friction and swing effect	Inclusion of the vertical one way supports and rigid hangers in analysis
OPER_A	$P_h$	No	User	Yes
OPER_B	$R_0$	Yes	User	Yes
<a href="#">OPER_R</a>	$R_0$	Yes	User	Yes
SUST_A	$P_h$	No	No	Yes
SUST_C	$P_h$	No	No	Reference (depending on their status on the previous Load Case)
DSGN	$P_h$	rigid/no	No	Yes
TEST	-	lock	User	Yes
TEST_B	$R_0$	lock/yes	User	Yes
MODAL	-	Yes	No	linearization
SAM	-	Yes	No	linearization

In the table above:

$P_h$  - spring hangers presetting, hot load. This value could be defined by User, otherwise will be calculated by Program. In case of OPER\_A type of analysis this value obtained from the Input Data, for OPER\_B is taken from the previous Load Case

$R_0$  - Spring Hanger Installation or Theoretical Cold Load: entered as input data for [OPER\\_R](#) load case, in other cases is computed by dPIPE

For OPER\_A/OPER\_B friction and swing effects may be included in analysis by USER. SUST\_C does not permit nonlinear effects. In the frame of MODAL analysis parameter [RH\\_PEND](#) controls use of the additional lateral horizontal stiffness for rod hangers.

Nonlinear work of one way vertical restraints is considered for all types of analyses. Exceptions are: SUST\_C and MODAL types. Within SUST\_C analysis one way supports are considered depending

on their status on the previous, operating Load Case (NLS='REF'). MODAL analysis assumes that all restraints are linear.

Load Case 'DSGN' is used for spring hanger design to determine design load (see [Appendix VI](#)). In doing so, the hangers, for which design load is not defined, are replaced with rigid vertical restraints. At the same time hangers with defined design loads are included in analysis by considering this load acting on the piping system.

The analysis of 'MODAL' type is used for determination of natural frequencies and mode shapes of piping system. These data is used in postprocessor for Response Spectrum or Time History Analysis.

'TEST' type of analysis is designed for simulation of hydraulic test procedure implemented just after piping installation: it's assumed that piping has no insulation and all springs are locked. Piping internal pressure, temperature and content are defined by [OPVAL](#) command. Stiffness of locked spring hangers is defined by [RH\\_STF](#) parameter.

The analysis of 'TEST\_B' type is used for the simulation of the Hydraulic Test conducted during operating life of the piping system. It is assumed that before hydraulic test piping system is deformed. Some spring hangers may be locked being preset in this pre-testing operating state.

"OPER\_R" type of analysis is designed for calculations when information for spring hanger installation load  $R_0$  is available. In this case, the program does not check if the presetting load for the spring hanger is within the range from [PMIN](#) to [PMAX](#)

The Table below specify default and available options for standard types of analyses:

Parameter	Type of Analysis:										
	DSGN	OPER_A	OPER_B	OPER_R	SUST_A	SUST_C	MODAL	TEST	TEST_B	SAM	-
LOAD (*)	W	W+P+T +D+[...]	W+P+T +D+[...]	W+P+T+ D+[...]	W+P+[ F]	W+P +[F]	-	W+P+ T+D	W+P+ T+D	D	ANY
HNG_STF	<a href="#">RGD</a> <a href="#">_SP</a> <a href="#">R</a>	NO	YES	YES	NO	NO	YES	<a href="#">RH_S</a> <a href="#">TF</a>	YES/ <a href="#">R</a> <a href="#">H_STF</a>	YES	NO/ YES
NLS(**)	YES	YES	YES	YES	YES	REF	-	YES	YES	LIN	YES/ REF
FRIC	NO	YES/ NO	YES/ NO	YES/ NO	NO	NO	NO	YES/ NO	YES/ NO	NO	NO/ YES
PEND	NO	YES/ NO	YES/ NO	YES/ NO	NO	NO	(***)	YES/ NO	YES/ NO	NO	NO/ YES

(\*) *LOAD* is a text parameter consisting of pre-defined characters and delimiters ("+"):

- W* – weight load;
- P* – pressure;
- T* – temperature loads;
- F* – concentrated forces;
- D* – displacements of supports;
- CS* - Cold Spring Load;

**BOW** - bending moment arising from the temperature stratification effect (see Appendix VIII)

For 'OPER\_A', 'OPER\_B', 'OPER\_R' types the following loads can optionally be included in [...]: concentrated forces (F), cold spring loads (CS) and bowing loads from the stratification effect (BOW);

(\*\*) NLS = 'REF' means that support nonlinearities are considered depending on the previous load case: for example, if a one way support has "uplifted" in the analysis under "full load" (W+P+T+D), then in the subsequent analysis, for which the option NLS = 'REF' is specified, this support will not be taken into account at all.

(\*\*\*) PEND parameter for 'MODAL' analysis could be set as 'NO' or specified as 'LCXX', where XX is a number of the relevant Load Case for calculation of loads affecting on the lateral stiffness due to swing effect.

Example:

```
SOLV "Analysis with determination of operating loads and selection of springs (#1)"
```

```
&LC MOD='$OPER' TYPE='DSGN' Note="Determination of working loads on springs" ; LC1
```

```
&LC MOD='$OPER' TYPE='OPER_A' PEND='NO' FRIC= 'NO' Note="Analysis for full load" ; LC2
```

```
&LC MOD='$COLD' TYPE='OPER_B' PEND='NO' FRIC = 'NO' Note="Selection of springs" ; LC3
```

```
&LC MOD='$OPER' TYPE='OPER_B' PEND='YES' FRIC='YES' Note="Stage II (full load)" ; LC4
```

```
&LC MOD='$OPER' TYPE='SUST_C' Note="Stage I" ; LC5
```

```
&LC MOD='$COLD' TYPE='OPER_B' PEND='YES' FRIC = 'YES' Note="Stage IV (cold load)"; LC6
```

## Specification for Dynamic Analyses (DCASE)

	Type	LC	Inp	Mcom	DK	TT	Del	Dtout	THA Avi	THA Strs	Note
▶ LD1	RSM	LC07	SP01	...					<input type="checkbox"/>		RSM
LD2	THA	LC07	TH01	...	0.02	21	0.005	0.01	<input type="checkbox"/>	TH	THA
* LD3									<input type="checkbox"/>		

Postprocessor Dynamic Analyses

DCASE command defines dynamic analysis cases and installs links between the modal load cases (see [SOLV](#) Command, [MODAL](#) type) and the set of the seismic or dynamic excitations (see [SPEC](#), [ACCE](#) and [DFRC](#) commands). In the input data file, this command should be placed between [SOLV](#) and [POST](#) commands.

**type:** general multi-line command

**Function:** specification for the options of dynamic analyses

## Parameter subcommand

### LD

#### Subcommand parameter :

**TYPE** defines type of the dynamic analysis

type:	<a href="#">TEXT</a>
unit:	-
default value:	<a href="#">DYN</a>
limitations:	'RSM', 'THA'

**LC** reference on the modal analysis Load Case defined in the [SOLV](#) command

type:	<a href="#">TEXT</a>
unit:	-
default value:	-
limitations:	LC should be defined in the command <a href="#">SOLV</a>

**INP** reference on the set of dynamic excitations (parameter SET of the [SPEC/ACCE/DFRC](#) comands)

type:	<a href="#">TEXT</a>
unit:	-
default value:	-
limitations:	the set should be defined before the appearance of this reference

**MCOM** is the type of modal combination of seismic responses

Type:	<a href="#">INTEGER</a>
Unit:	-
Default value:	2

The MCOM parameter is an integer, which bit mask contains several keys at once for setting the rules of the modal combination of seismic responses. In order to generate this parameter, it is recommended to use the following dialog from the [DDE](#) spreadsheet ("Service/Options/Control parameters/Dynamic" menu):

The fields of the given dialog can take the following values:

Determination of the rules of the modal combination of seismic responses

Dialog field	allowable values	Notes
Modal Combination Rule	SRSS	"Square root from the sum of squares" method
	NRC GRM	Grouping method in US NRC edition
	NRC_TPM	10 % summation method in US NRC edition
	NRC_DSC	"Double sum" method in US NRC edition
	ISM_CQC	"Complete Quadratic Combination" method for multi-support excitation
	DSC	"Double sum" method
	CQC	"Complete Quadratic Combination" method
Missing Mass Effect Static Correction	Yes/No	
<b>Multi-support Excitation Parameters</b>		
Seismic Anchor Movements (SAM)	Yes/No	
Add SAM for stresses	Yes/No	
Support's Groups combination	ABS/SRSS	
<b>Additional options<sup>1)</sup></b>		
Modal damping (DK) in fractions of the critical value	0.05	at DK = -1 the modal damping according to Code Case N-411 is assumed
Time (duration) of seismic excitation (TT), s	15.0	

1) Both parameters, DK and TT, are used for the "double sum" method (NRC\_DSC and DSC); the DK parameter is used for the CQC (ISM\_CQC, CQC) method.

**TT** - The total time of the the dynamic excitation. This parameter may be used also in the frame of [RSM](#) for the DSC combination rule (see [MCOM](#)).

type:	<a href="#">REAL</a>
unit:	sec
Default values:	0
limitations:	$\geq 0$

**DEL** - integration step

Type:	<a href="#">REAL</a>
Unit:	sec
Default values:	0
Range of possible values:	$\geq 0$

*If DEL = 0, then the integration step will be computed by the program automatically. If the DEL1 integration step computed by the program is less than the specified value, then DEL = DEL1*

**DTOUT** - the results output step in case of Time History Analysis

Type:	<a href="#">REAL</a>
Unit:	sec
Default values:	DEL
Range of possible values:	$\geq 0$

**DK** - modal damping (fractions of critical). When RSM is used, DK is applicable as a parameter for CQC or DSC modal rule (see [MCOM](#)).

Type:	<a href="#">REAL</a>
Unit:	-
Default values:	0
Range of possible values:	$0 \leq DK \leq 1$

**THA\_STRS** - the method of stress computation in piping elements in case of analysis according to [THA](#) ([DYN](#)='THA')

type:	<a href="#">TEXT</a>
unit:	-
default value:	'TH'
limitations:	'SRSS', 'TH', 'FAST'

*When THA\_STRS = 'SRSS' the program will find maximum modal responses of the system by time integration of the equations of motion. In doing so, for computing stresses in the piping system, a procedure is used, which is similar to the analysis according to [RSM](#). It is a "fast" but less accurate stress evaluation method than that when THA\_STRS = 'TH'. In the latter case, the stresses are to be found for each integration step, and the maximum values are indicated in the printout. THA\_STRS = 'FAST' corresponds to the method of "fast" computation of response parameters of the piping system based on the analysis of system kinetic energy maximums for the time of integration of the equations of motion. It is recommended to use this option in debugging calculations of models when the main analysis time falls to integration of the equations of motion. From the experience of calculations performed it follows*

that the use of this options allows to correctly determine the response parameter maximums ~ in 90% of cases. For final calculations the procedure for response parameter computation at each integration step shall be used. For RD and PNAE Codes stresses dependent from the dynamic transient loads are calculated several times for selected time points, while for all other Norms stresses are calculated once based on maximal components of elements loads.

Printout of the THA results is carried out according to the table given below:



output value	maximum
stresses S2_MRZ, S2_PZ1, S2_PZ2, S_I_PZ (code = 'PNAE'/'PNAE_HT'/'RD')	maximal values are printed for stresses calculated on each time step
stresses EQ9_B, EQ9_C, EQ9_D, SGM2, SOL (code = 'ASME_NB'/'ASME_NC', 'B311'/'EN')	calculated for maximal value of $M = \sqrt{M_x^2 + M_y^2 + M_z^2}$
internal forces for PIPE, BEND and REDU elements	all 6 components are printed for time when $M = \sqrt{M_x^2 + M_y^2 + M_z^2}$ is maximum
internal forces for all elements except PIPE, BEND and REDU	output of the maximal magnitude for each directional component independently
displacements	
accelerations	
support's loads	
dampers (loads and displacements)	independent output for horizontal (X and Y SRSS Square Root of Sum Squares) and vertical directions

**THA\_AVI** - a flag for the output of forced vibration animation in performing the analysis according to [THA](#) (DYN='THA')

type:	<a href="#">TEXT</a>
unit:	-
default value:	'NO'
limitations:	'YES' or 'NO'

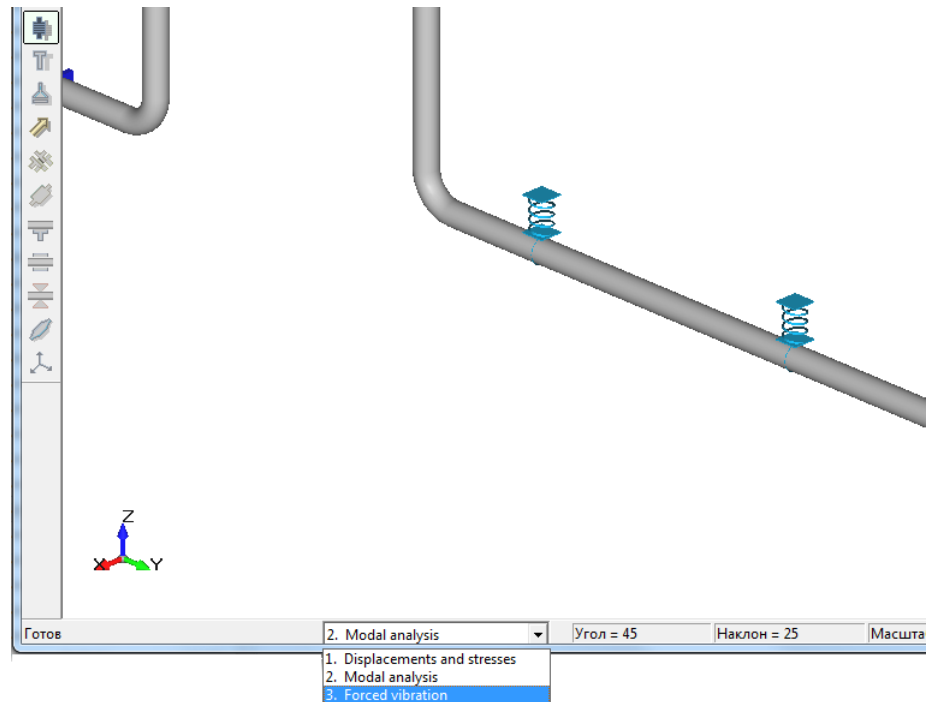
When THA\_AVI = 'YES' the program will record the deformed state of the system for each time step. These results can be viewed thereafter in the PIPE3DV program by selecting the "Forced vibration" line in the bottom window with the list of output results:



and then it is possible to use  and  buttons for viewing the animation. It should be kept in mind that when the forced vibration is recorded the size of the <model>.bin file will increase significantly!

**NOTE**

Note / Comment

type:	<a href="#">STRING</a>
unit:	-
default value:	-
limitations:	see limitations for the string values of parameters

Example:

```
DCASE
& LD type = 'RSM', lc = 'LC7', inp = 'SET1', mcom = 6 ; LD1
& LD type = 'THA', lc = 'LC7', inp = 'THA', mcom = 6, dk = 0.02, tt = 20, del =
0.001, dtout = 0.001 ; LD2
```

**Specification for postprocessor (POST)**

The POST command defines the specification for post-processing of the results and shall be placed in the input data file only after SOLV command. The values of parameters to be used in the POST command depend upon the piping stress codes. The following codes are used in this version: Russian Nuclear Code PNAE [\[REF\\_1\]](#), Russian Power Piping Code RD [\[REF\\_2\]](#), American Nuclear Code ASME BPVC NB/NC-3600 [\[REF\\_3\]](#), European Code EN 13480-3 [\[REF\\_10\]](#), American Power Piping Code ASME B31.1 [\[REF\\_12\]](#).

**type:** general multi-line command

**Function:** specification for post-processing of the results.

**Parameter subcommand**

<b>RES</b>	type of the results being processed
------------	-------------------------------------

type: [TEXT](#)  
 unit: -  
 default value: -  
 limitations: [see \(1\)](#)

### Subcommand parameter :

**LS** load set: specification for results output

type: [TEXT](#)  
 unit: -  
 default value: -  
 limitations: [see \(2\)](#)

**RULE** rule for results processing

type: [TEXT](#)  
 unit: -  
 default value: 'SUM'  
 limitations: [see \(3\)](#)

**OUT** option for printing and output of results

type: [TEXT](#)  
 unit: -  
 default value: 'YES'  
 limitations: 'YES', 'NO'

**NOTE** Note / Comment

type: [STRING](#)  
 unit: -  
 default value: -  
 limitations: see limitations for the string values of parameters

### Note:

1) RES =

Designation:	Description
DISP	displacements
SUPP	support reactions
FORC	internal forces

Stresses depending upon the piping stress codes:

**CODE = 'PNAE', 'PNAE\_T', 'NTD\_ACI':**

<b>S1</b>	Stresses of S1 category. Allowable values are calculated for the same service level as the previous load set.
-----------	---

<b>S2_NUE</b>	stress of S2 category (NOC - Normal operating conditions)
<b>S2_NNUE</b>	stress of S2 category (AOC - Abnormal operating conditions)
<b>S2_MRZ</b>	stress of S2 category (SSE)
<b>S2_PZ1</b>	stress of S2 category (OBE, category 1)
<b>S2_PZ2</b>	stress of S2 category (OBE, category 2)
<b>SRK</b>	stress of SRK category (for High Temperature Piping see <a href="#">Appendix V</a> )
<b>SAF</b>	stress of SAF category ( <b>Load set should consist of two arguments!!!</b> )
<b>S2_HDR</b>	stress of S2 category (hydraulic tests)

**CODE = 'RD':**

<b>S_I</b>	effective stress according to stage I
<b>S_II</b>	effective stress according to stage II
<b>S_III</b>	effective stress according to stage III
<b>S_IV</b>	effective stress according to stage IV
<b>S_I_PZ</b>	effective stress for NOC + OBE
<b>S_H</b>	effective stress under stage I for hydraulic test mode

**CODE = 'ASME\_NC':**

<b>EQ8</b>	stress due to sustained loads (design conditions), equation (8) NC-3652
<b>EQ9_B</b>	stress due to sustained and occasional loads for level B Service Limits, equation (9), NC-3653.1
<b>EQ9_C</b>	stress due to sustained and occasional loads for level C Service Limits, equation (9), NC-3654
<b>EQ9_D</b>	stress due to sustained and occasional loads for level D Service Limits, equation (9), NC-3655
<b>EQ10</b>	stress due to thermal expansion, equation (10), NC-3653.2-a
<b>EQ10A</b>	stress due to single nonrepeated anchor movement, equation (10a), NC-3653.2-b
<b>EQ11</b>	stress due to a combination of sustained loads and thermal expansion, equation (11), NC-3653.2-c
<b>EQ11A</b>	stress due to reverse loads, equation (11a), NC-3653.2-d

**CODE = 'ASME\_NB':**

<b>EQ9_DC</b>	stress due to sustained loads, Consideration of Design Conditions, equation (9) NB-3652
<b>EQ9_B</b>	stress due to sustained loads compatible with Service Limit B, equation (9) NB-3654
<b>EQ9_C</b>	stress due to sustained and occasional loads for level C Service Limits, equation (9), NB-3655
<b>EQ9_D</b>	stress due to sustained and occasional loads for level D Service Limits, equation (9), NB-3656
<b>EQ10</b>	Primary Plus Secondary Stress Intensity Range, equation (10), NB-3653.1
<b>EQ11</b>	Peak Stress Intensity Range, equation (11), NB-3653.2
<b>EQ12</b>	Simplified Elastic-Plastic Discontinuity Analysis, equation (12), NB-3653.6-a
<b>EQ13</b>	the primary plus secondary membrane plus bending stress intensity, excluding thermal bending and thermal expansion

	stresses, equation (13), NB-3653.6-b
--	--------------------------------------

**CODE = 'EN':**

<b>SGM1</b>	longitudinal stress due to sustained loads, equation (12.3.2-1)
<b>SGM1T</b>	longitudinal stress due to sustained loads under Test Conditions: see equation (12.3.2-1). Allowable stresses are defined according chapter 5.2 through the material data (see parameter <a href="#">ST</a> )
<b>SGM2</b>	longitudinal stress due to to sustained and occasional or exceptional loads, equation (12.3.3-1)
<b>SGM3</b>	Stress range due to thermal expansion and alternating loads, equation (12.3.4-1)
<b>SGM4</b>	stress range due to sustained (weight + pressure) and alternating loads, equation (12.3.4-2)
<b>SGM5</b>	Additional conditions for the creep range: stress range due to sustained (weight + pressure) and alternating loads, equation (12.3.5-1)
<b>SGM6</b>	Stresses due to a single non-repeated support movement, equation (12.3.6-1)

**CODE = 'ASME\_B311':**

<b>SL</b>	stress due to sustained loads
<b>SOL</b>	stress due to sustained and occasional loads
<b>SE</b>	stress Due to Displacement Load Ranges

[Appendix V](#) contains recommendations and rules for composing of typical specifications for analysis and post-processing.

Stress evaluation according to Russian RD 10-249-98 [[REF 2](#)] for Hydraulic Test mode is conducted in dPIPE with use of [S\\_H](#) stress category. It corresponds to the stress calculation for the first stage of analysis. The allowable stress for this category shall be calculated as follows: in the procedure for determination of the trial pressure (Item 2.8 of RD), an allowable stress is defined according to Table 2.8, where the value of  $[\sigma]$  is taken as  $[\sigma] = \sigma_{0,2}/1.1$  for carbon, heat-resistant and austenite steel (rolled and forge). Strength criterion set for the first stage of analysis is  $\sigma_{\text{eff}} \leq 1.1[\sigma]$ . So the allowable stress for the hydraulic test mode shall be written in the following form:  $\sigma_{\text{add. h.t.}} = \sigma_{0,2}$ .

If the input data of the dPIPE model contain the yield strength values for the materials being used ([SY parameter](#), [MAT command](#)), then the program will directly calculate the allowable stress values in accordance with the formula given above. In case of such data being missing, it is assumed that  $\sigma_{0,2} = 1.5*[\sigma]$  where nominal allowable stress  $[\sigma]$  corresponds to the [SA](#) parameter of the [MAT](#) command. An example of the specification for analysis for the hydraulic test mode is given in [Appendix V](#).

- 2) *LS parameter determines how the results of analysis should be combined in order to obtain the required values. The expression for LS may contain references to the Load Cases (LC) described in the [SOLV](#) command, to the dynamic load case (LD) defined in [DCASE](#) command and to the Load Sets (LS) being created by the previously defined post-processor commands. For example, the expression 'LC2-LC1+LS1' defines that within the current LS it is necessary to generate the results as the difference between the values of LC N 2 and LC N 3 + the value from the N 1 set described earlier. The following characters are used as delimiters between the LC and LS sets: "+" (plus), "-" (minus) ", " (comma) " " (space), ":" (colon). The "+" and "-"*

characters determine the sign of weight coefficients. The " " (space) and "," (comma) characters denote the list of sets, to which the rule will then be applied as determined by the *RULE* parameter. The ":" (colon) character is used for a short form of listing of the range of values. For example, the record *LS* = 'LC1:LC3' is equivalent to the record *LS* = 'LC1, LC2, LC3'. **The order of references defined in the specification is important. Firstly should come references for Load Cases (LC), then references on dynamic analyses (LD) and finally Load Sets (LS).**

3) *RULE* =

**'SUM'** summation of sets;

**'RANGE'** search with determination of the maximum difference.

**'REF'** correction of the elements internal forces to the "cold" (reference) modulus of elasticity (to be used only in combination with *RES* = 'FORC'):  $F = (E_c/E_h)*F$  ;

**'SEISM'** "seismic" rule of component summation for most "unfavourable" case: if the *LS* parameter is specified as *LS* = 'LC1+LC4', then the resulting value will be determined as the sum of absolute values from the set of |LC1i| + |LC4i|, and the sign shall be taken according to the first summand. For example:

<i>LC1</i> :	43295	70	-3425	928	-2626	-137
<i>LC4</i> :	43041	938	2078	22344	3939	1379
<i>SEISM</i> :	86336	1008	-5503	23272	-6565	-1516

the rule: *RULE* = "SEISM" is used only in the combination with *RES* = 'FORC', 'DISP' u 'SUPP';

**'MAX'** determination of maximum in absolute value of the components of displacements, supports reactions, stresses and element's forces and moments

**'ABS'** summation of sets in absolute value

**'H\_REL'** identifier of the transfer of loads to the supports with the account of relaxation of temperature forces. It is used only for high-temperature piping systems in combination with *RES* = 'SUPP'

**'C\_REL'** identifier of the transfer of loads to the supports with the account of cold springing. It is used only for high-temperature piping systems in combination with *RES* = 'SUPP'

**SRSS** combination by Square Root of the Sum of Squares rule. The rule is applicable for the internal forces ('FORC'), support's reactions (SUPP) and displacements ('DISP')

**S\_SRSS** "seismic" SRSS rule: magnitude of resulting value is SRSS of two combined components and the sign is taken by the first term. The rule is applicable for the internal forces ('FORC'), support's reactions (SUPP) and displacements ('DISP')

**SAM** option to extract displacements, internal forces and supports reactions from the action of Seismic Anchor Movements. Applicable for *RES* = 'DISP'/'SUPP'/'FORC'. The *LOAD* parameter should refer on the dynamic load case (LD). It is also possible to use this option for calculating stresses from the action of the Seismic Anchor Motion for Service Levels B, C, and D (*RES* = 'EQ\_9B (C, D)') in accordance with ASME NB/NC Code edition 2010 and later

**RVRS** option to indicate that applied dynamic loads are considered as "reversing loads" for piping stress analysis. Compliant with ASME NB/NC Code Revision 2010 and later (*RES* = 'EQ\_9B (C, D)') and EN code, Revision 2020 (*RES* = 'SGM2')

4) If the multiplier of the first term in the "seismic" combination is set to zero, then internal pressure for stress calculations is set to zero as well. It allows to estimate the contribution of the "pure" seismic loads in stresses:

& res = 'S2\_MRZ', ls = "0\*LC2+LC4", note = "Stresses S2 (SSE)" ;  
LS4

Example:

```

POST
&RES='S2_NUE' LS="LC2" RULE='SUM' OUT='YES' NOTE="Stress of S2
category"
&RES='SRK' LS="LC1-LC3" RULE='SUM' OUT='YES' NOTE="Stress of SRK
category"
&RES='SAF' LS="LC1-LC3" RULE='SUM' OUT='YES' NOTE="Stress of SAF
category"
&RES='DISP' LS="LC2" RULE='SUM' OUT='YES' NOTE="Weight movements"
&RES='DISP' LS="LC1-LC3" RULE='SUM' OUT='YES' NOTE="Thermal expansion"
&RES='SUPP' LS="LC1" RULE='SUM' OUT='YES' NOTE="Hot Loads"
&RES='SUPP' LS="LC3" RULE='SUM' OUT='YES' NOTE="Cold loads"

```

## Specification for fatigue analysis (FATG)

The FATG command defines the specification for fatigue analysis and shall be placed in the input data file only after description of the [SOLV/POST](#) command. The following dialog corresponds to this command in the [DDE](#) interface:

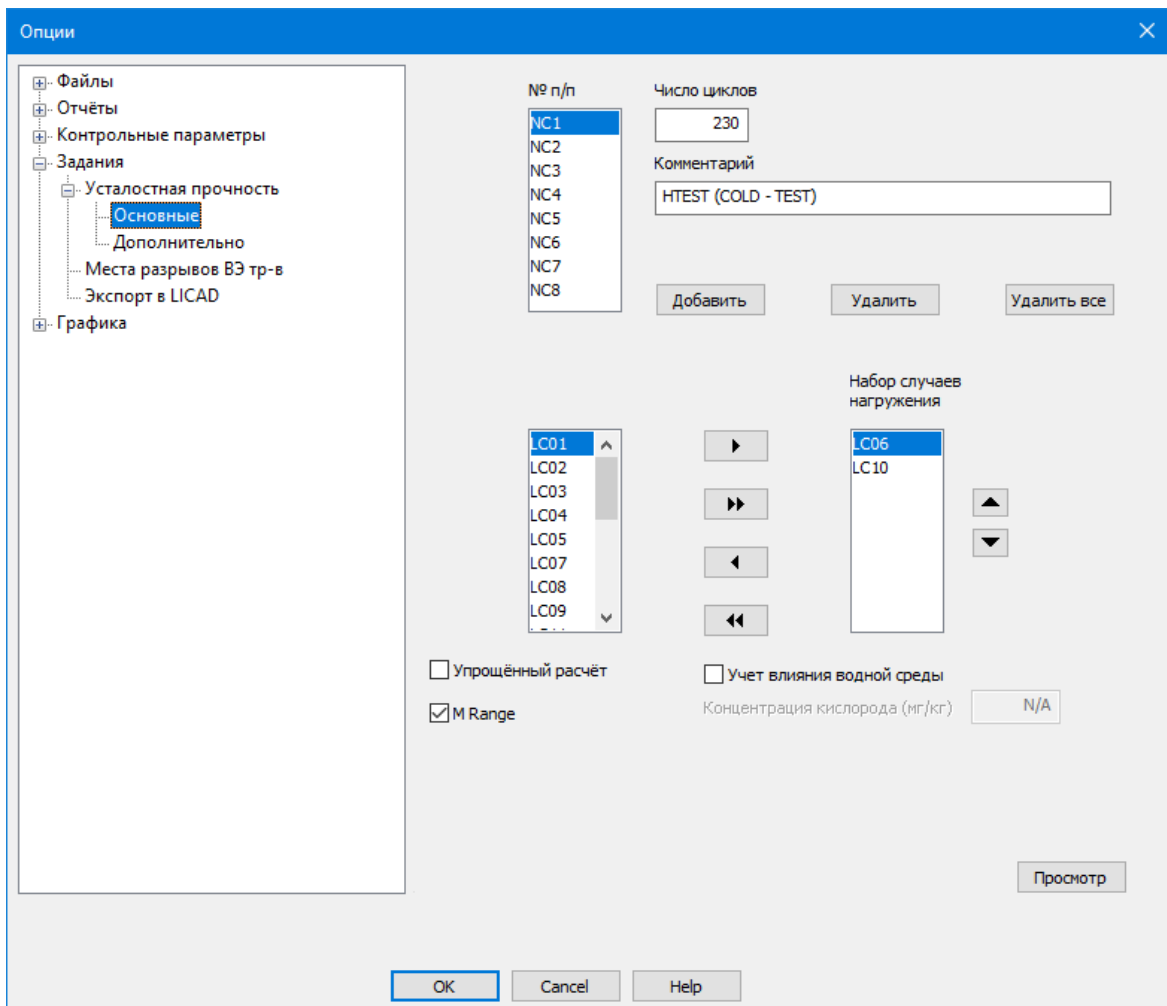

**type:** general multi-line command

**Function:** specification for piping Fatigue Analysis and calculation of the Cumulative Usage Factor (CUF)<sup>1)</sup>.

**Parameter**

**FATG\_SAF** flag for "simplified" analysis (available for [CODE\\_](#) = 'PNAE', 'PNAE\_T', 'ASME\_NB') in order to determine the individual design number of cycles in case of system transients from one operational state into another. With the option being activated, it is allowed to specify only paired load cases for each of the transients under consideration.

type: [TEXT](#)  
 unit: -  
 default value: 'NO'  
 limitations: 'YES', 'NO'

**M\_RANGE** option to use *range of mechanical loads* for equation (13) according to ASME NB-3600 or "SRK" stress for PNAE in case of analysis according to the simplified elastic-plastic analysis (see [PNAE\\_KE](#) parameter).

type: [TEXT](#)  
 unit: -  
 default value: 'NO'  
 limitations: 'YES', 'NO'

**FAT\_ENV** option if the effect of water environment will be used for calculation of the fatigue curves. Effective only if CODE = 'PNAE' and CODE\_YEAR= 2022. See [Appendix XVII](#) for details

type: [TEXT](#)  
 unit: -  
 default value: 'NO'  
 limitations: 'YES', 'NO'

**KO** global value for water oxidation. Could be redefined by [ENVFAT](#) command.

type: [REAL](#)  
 unit: mg/kg  
 default value: 0.  
 limitations: ≥0.

**Subcommands:**

**NC** number of cycles for the loading history specified

type: [INTEGER](#)  
 unit: -  
 default value: -  
 limitations: > 0

**Subcommand parameter :**

**SEQ** loading history, sequence of load cases or load sets

type: [TEXT](#)  
 unit: -  
 default value: -  
 limitations: load cases (load sets) described preliminarily in the SOLV (POST) command

**NOTE** Note / Comment

type: [STRING](#)  
 unit: -  
 default value: [blank](#)  
 limitations: see limitations for the string values of parameters

**Additional data for fatigue strength analysis:**

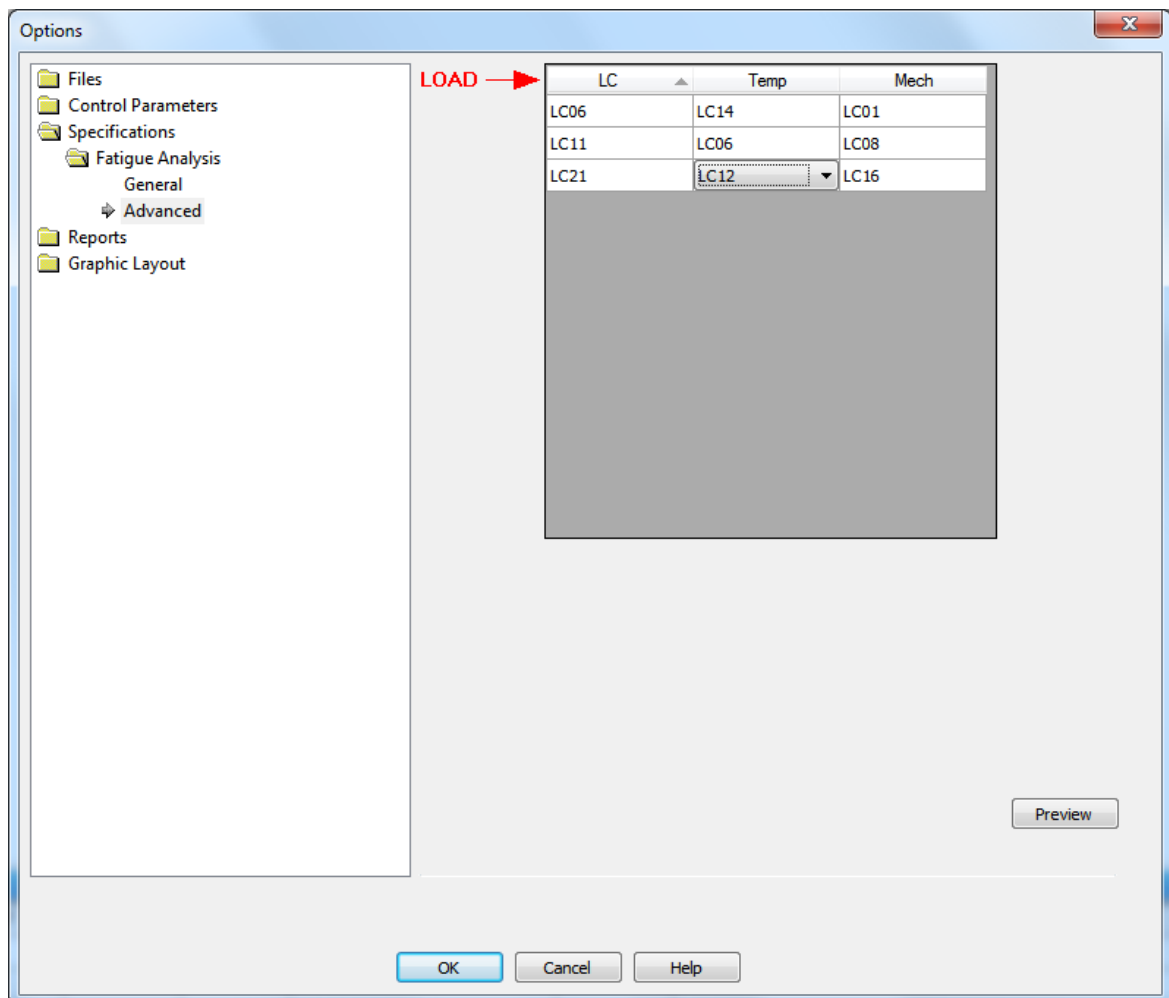

**LOAD** reference to LC or LS that already included in SEQ parameter

type: [TEXT](#)  
 unit: -  
 default value: -

limitations: load cases or load sets described in one of the NC subcommands (SEQ parameter)

### Subcommand parameter :

**TEMP** reference to LC or LS, in which the temperature loads are determined for the account in equation (12) according to ASME NB-3600 or SRK' stress according to the simplified elastic-plastic analysis procedure (see [PNAE\\_KE](#) parameter).

type: [TEXT](#)  
 unit: -  
 default value: -  
 limitations: load cases or sets of results described in one of the NC subcommands (SEQ parameter)

**MECH** reference to LC or LS, in which the mechanical loads are determined for the account in equation (13) according to ASME NB-3600 or SRK" stress according to the simplified elastic-plastic analysis procedure ([PNAE\\_KE](#) parameter).

type: [TEXT](#)  
 unit: -  
 default value: -  
 limitations: load cases or sets of results described in one of the NC subcommands (SEQ parameter)

### Example:

```
FATG
& nc = 3000, seq = "LC1, LC6"
& nc = 3800, seq = "LC1, LC4, LC6"
& nc = 10000, seq = "LC1, LC2, LC3, LC4, LC5, LC6"
```

### Note:

- (1) The fatigue strength analysis shall be performed only for the stress codes of PNAE ([CODE](#) = 'PNAE'), NTD A.C.I. ([CODE](#)='NTD\_ACI') and ASME BPVC NB-3600 ([CODE](#)= 'ASME\_NB'). For piping working in the creep range this command is available only for PNAE ([CODE](#) = 'PNAE\_T') with option [simplified analysis](#).
- (2) An example of the fatigue analysis is given in [\[REF 11\]](#)

### Specification for HELB analysis (POST\_HELB)

POST\_HELB provides parameters for High Energy Lines Break (HELB) analysis (location of intermediate postulated ruptures). Command is applicable only for the following Codes: PNAE [\[REF](#)

1] or ASME NC/NB Code [[REF 3](#)] or EN Code [[REF 10](#)]. The command should be located after [SOLV](#) and [POST](#) specifications. See [Appendix XVIII](#) for HELB analysis criteria and its adaptation for different Codes.

**Type:** general multi-line command

**Function:** Specification for HELB Analysis

**Parameters:**

**CUF** Criterion for Cumulative Usage Factor (CUF) calculated from Fatigue analysis and used to locate piping rupture

type: [REAL](#)  
 unit: -  
 default value: 0.4  
 limitations: >0; < 1

**RUPTURE** Scale factor used for allowable stresses to locate piping rupture

type: [REAL](#)  
 unit: -  
 default value: 0.8  
 limitations: >0; <= 1

**CRACK** Scale factor used for allowable stresses to locate through-wall crack

type: [REAL](#)  
 unit: -  
 default value: 0.5\*[RUPTURE](#)  
 limitations: >0; <= 1

**MECH\_LS** Reference on Load Set ([POST](#) command) that depends on Code used for analysis. For PNAE and ASME\_NC refers to Load Set for stresses due to Sustained Loads + OBE. For ASME\_NB Class 1 analysis refers to the stress range excluding thermal expansions analysis

type: [TEXT](#)  
 unit: -  
 default value: -  
 limitations: PNAE Code: LS for [S2\\_PZ1](#), [S2\\_PZ2](#),  
 ASME\_NC Code: LS for [EQ9\\_B](#)  
 ASME\_NB Code: LS for [EQ13](#)

**RANGE\_LS** Reference on Load Set ([POST](#) command) with thermal expansion stress

type: [TEXT](#)  
 unit: -

default value: 'FATG' (range stresses calculated within fatigue analysis procedure. Command [FATG](#))  
 limitations: PNAE Code: LS for ['SRK'](#) or 'FATG'  
 ASME\_NC Code: LS for [EQ10](#)  
 ASME\_NB Code: LS for [EQ12](#) or 'FATG'

**HELB\_STR**

prefix used in the name of piping classified as High Energy piping. If prefix does not specified all pipes in the model are considered as High Energy.

type: [TEXT](#)  
 unit: -  
 default value: -  
 limitations: 8 symbols length

**DOC**

an identifier for selecting a criterion document by which the locations of the postulated piping ruptures are determined. There are two options available: DOC = 'ANSI' and DOC = 'SRP'. In the first case, the criteria are determined according to the document ANSI/ANS 58.2 [[REF 19](#)], in the second in accordance with SRP Section BTP 3-4, NUREG-0800, [[REF 20](#)]

type: [TEXT](#)  
 unit: -  
 default value: [blank](#)  
 limitations: [blank](#), 'ANSI', 'SRP'

Example:

POST\_HELB CUF = 0.4, RUPTURE = 0.8, MECH\_LS = 'LS03', RANGE\_LS = 'FATG', HELB\_STR = 'HELB'

**Specification for report generation (POST\_REP)**

The POST\_REP command specify options for generation of results summary tables. The command shall be placed in the input data file after the [SOLV](#) and [POST](#) commands.

**type:** general one-line command

**Function:** generation of results summary tables

**Parameters:****REP\_TYPE**

user-defined type of report

type: [TEXT](#)  
 units: -  
 default value: -  
 limitations: 'SPBAEP', 'MOAEP', 'NIAEP', 'ADVANCED'

**LOAD\_HOT**

reference to the Load Case ([SOLV](#) command) that defines Hot Load for Spring Hangers.

type: [TEXT](#)  
 units: -  
 default value: -

limitations: existing Load Cases specified by [SOLV](#) command

**LOAD\_COLD**

reference to the Load Case ([SOLV](#) command) that defines Cold Load for Spring Hangers.

type: [TEXT](#)

units: -

default value: -

limitations: existing Load Cases specified by [SOLV](#) command

**LOAD\_DES**

reference to the Load Case ([SOLV](#) command) that defines Design Load for Spring Hangers

type: [TEXT](#)

units: -

default value: -

limitations: existing Load Cases specified by [SOLV](#) command

**LOAD\_HT**

reference to the Load Case ([SOLV](#) command) that calculates Operating Load for Spring Hangers corresponding to the Hydraulic Test

type: [TEXT](#)

units: -

default value: -

limitations: existing Load Cases specified by [SOLV](#) command

**LOAD\_SEISM**

reference to the Dynamic Load Case ([DCASE](#) command) or Load Set with type = 'SUPP' ([POST](#) command) representing seismic loads to be printed in supports' summary tables

type: [TEXT](#)

units: -

default value: LD1

limitations: existing Load Cases specified by [SOLV](#) command

**SKIP\_SUP**

identifier for designation of the support in order to exclude it from the results. The set of characters determined by the SKIP\_SUP parameter shall be placed at the beginning of the string parameter NOTE (for example, if SKIP\_SUP = "\$", then the following record shall be present in the command for the support being excluded:  
*2450: SUP note = "\$support")*

type: [TEXT](#)

units: -

default value: '\$\_NULL'

limitations: length up to 8 characters

**SKIP\_STR**

identifier for designation of the piping segment in order to exclude it from the results. The set of characters determined by the SKIP\_STR parameter shall be placed at the beginning of the string parameter

NAME (for example: 10: F dc = -1, 1, 0, cs = '630x10', lg = 'LG1',  
name = "\$" )

type: [TEXT](#)  
units: -  
default value: '\$\_NULL'  
limitations: length up to 8 characters

#### ANC\_CS

option for the output coordinate system for the anchor and 6-  
component supports reactions printed in the summary tables with  
results (file \*.sup)

type: [TEXT](#)  
units: -  
default value: 'G' (global c.s.)  
limitations: 'G' (global c.s.), 'L' (local c.s.)

#### RSTR\_CS

option for the output coordinate system for the restraints reactions  
printed in the summary tables with results (file \*.sup)

type: [TEXT](#)  
units: -  
default value: 'G' (global c.s.)  
limitations: 'G' (global c.s.), 'L' (local c.s.)

#### SUP\_CRD

option for additional output of the global coordinates in the summary  
tables with results containing supports reactions (file \*.sup, option is  
valid for all types of supports)

type: [TEXT](#)  
units: -  
default value: 'NO'  
limitations: 'YES', 'NO'

#### SUP\_SKIP

flag for automatic exclusion from the resulting tables of listing  
supports located on the piping sections labeled by the [SKIP\\_STR](#)  
label

type: [TEXT](#)  
units: -  
default value: 'YES'  
limitations: 'YES', 'NO'

#### SKIP\_OUT

flag of automatic exclusion of the supports located at the piping  
segments with the [SKIP\\_STR](#) mark from the all resulting tables

type: [TEXT](#)  
units: -  
default value: 'NO'

limitations: 'YES', 'NO'

**OTT\_W**

reference to the Load Case ([SOLV](#) command) or the Load Set ([POST](#) command), which contains calculated weight loads. It is used for the evaluation of valve nozzles<sup>(2)</sup>.

type: [TEXT](#)

units: -

default value: -

limitations: existing Load Case specified by [SOLV](#) command or existing Load Set ([POST](#) command) with type = 'FORC'

**OTT\_T**

reference to the Load Case ([SOLV](#) command) or the Load Set ([POST](#) command), which contains calculated thermal expansion loads. It is used for the evaluation of valve nozzles<sup>(2)</sup>.

type: [TEXT](#)

units: -

default value: -

limitations: existing Load Case specified by [SOLV](#) command or existing Load Set ([POST](#) command) with type = 'FORC'

**OTT\_PZ**

reference to the Load Set ([POST](#) command), which contains combination of sustained (weight) and seismic loads corresponding to OBE. It is used for the evaluation of valve nozzles<sup>(2)</sup>.

type: [TEXT](#)

units: -

default value: -

limitations: existing Load Set ([POST](#) command) with type = 'FORC'

**OTT\_MRZ**

reference to the Load Set ([POST](#) command), which contains combination of sustained (weight) and seismic loads corresponding to SSE. It is used for the evaluation of valve nozzles<sup>(2)</sup>.

type: [TEXT](#)

units: -

default value: -

limitations: existing Load Set ([POST](#) command) with type = 'FORC'

**OTT\_AS**

reference to the Load Set ([POST](#) command), which contains combination of the sustained (weight) and accidental piping break loads . It is used for the evaluation of valve nozzles<sup>(2)</sup>.

type: [TEXT](#)  
 units: -  
 default value: -  
 limitations: existing Load Set ([POST](#) command) with type = 'FORC'

**ECOLD**

option to ignore scaling of the internal forces and moments to the cold (reference) Young Modulus. If ECOLD = 'YES' internal forces/moments are kept unchanged. This parameter suppresses [E\\_MOD](#) option for stress calculation.

type: [TEXT](#)  
 units: -  
 default value: 'NO'  
 limitations: 'YES', 'NO'

**SRK\_RMT**

option to take into account tensile stresses for calculation of allowable stresses for [SRK](#) stress category (in accordance with item 5.4.7 of PNAE), [[REF 1](#)].

type: [TEXT](#)  
 units: -  
 default value: 'NO'  
 limitations: 'YES', 'NO'

**IL\_SBP**

reference to the one of the stress categories taken into account the seismic inertia loads for small bore pipes, see [Appendix XV](#)

type: [TEXT](#)  
 units: -  
 default value: -  
 limitations: reference to the Load Set ([LS](#)) previously defined by the [POST](#) command. Depending on the [CODE](#) it should be type of: S2\_MRZ, S2\_PZ1, S2\_PZ2, S\_I\_PZ, EQ9\_B, EQ9\_C, EQ9\_D, SOL, SGM2, SOL

**IL\_LBP**

reference to the one of the stress categories taken into account the seismic inertia loads for "big" diameter pipes, see [Appendix XV](#)

type: [TEXT](#)  
 units: -  
 default value: -  
 limitations: reference to the Load Set ([LS](#)) previously defined by the [POST](#) command. Depending on the [CODE](#) it should be type of: S2\_MRZ, S2\_PZ1, S2\_PZ2, S\_I\_PZ, EQ9\_B, EQ9\_C, EQ9\_D, SOL, SGM2, SOL

**SL\_SBP**

reference to the one of the stress categories taken into account secondary seismic loads for small bore pipes (Seismic Anchor Movement), see [Appendix XV](#)

type: [TEXT](#)  
 units: -  
 default value: -  
 limitations: reference to the Load Set ([LS](#)) previously defined by the [POST](#) command. Depending on the [CODE](#) it should be type of: SRK, S\_III, EQ10, SGM3, SE

Example:

```
POST_REP load_hot = 'LC4', load_cold = 'LC6', load_des = 'LC1', skip_str = '$', skip_out = 'ye
```

**Note:**

- (1) See. [Appendix VI](#);
- (2) Reference to the values of permissible loads shall be determined by the [OTT\\_REF](#) parameters for the commands describing valves of various configuration. The permissible loads shall be set in the `vlv_ott.dbs` file.
- (3) In case when `REP_TYPE = 'ADVANCED'` is set, the form of summary tables in the `*.sup` file changes, and the results of spring design are brought into conformity to the [SPR\\_SFPMIN](#), [SPR\\_VARTOL](#) and [SPR\\_TRTRAV](#) parameters. See also [Appendix VI](#)

**Specification for Support's Allowable Loads (SUP\_LOADS)**

Command `SUP_LOADS` is used to specify correspondence between sets of Support's allowable Loads defined in file [SUP\\_LDS.MDB](#) and Load Sets and Load Cases defined by [SOLV](#) and [POST](#) commands.

**Type:** general multi-line command

**Parameters:****TABLE**

reference on standard's name

type: [STRING](#)  
 units: -  
 default value: -  
 limitations: should coincide with one of the standards names existing in file [SUP\\_LDS.MDB](#) (see field Table Name, [Appendix XII](#))

**Subcommand:****MODE**

The reference name of the operation mode or load combination for which the calculated and allowable loads are compared. The mode name must strictly correspond to the names predefined in the `SUPPORTS` (`MOD1`, `MOD2`, `MOD3`) or `LOADS` tables ("Labels" column) in the [SUP\\_LDS.MDB](#) file

type: [TEXT](#)  
 units: -  
 default value: -

limitations: predefined names in SUPPORTS or LOADS tables in [SUP\\_LDS.MDB](#) file

## LOAD

reference to the Load Case ([SOLV](#) command) or the Load Set ([POST](#) command), which contains supports reactions to be evaluated versus allowable values defined in the database, [SUP\\_LDS.MDB](#) file.

type: [TEXT](#)

units: -

default value: -

limitations: existing Load Case specified by [SOLV](#) command or existing Load Set

([POST](#) command) with type = 'SUPP'

### Notes:

- 1) The previous syntax of this command is acceptable as well:

```
SUP_LOADS table = "LISEGA 2010RS", sup_mod1 = 'LC1', sup_mod2 = 'LS7', sup_mod3 = 'LS8'
```

but after editing the dp5 file in the [DDE](#) spreadsheet it will be converted in a new format:

```
SUP_LOADS table = "LISEGA 2010RS"
& mode = 'HYЭ', load = 'LC1'
& mode = 'HYЭ+MP3', load = 'LS7'
& mode = 'HYЭ+П3', load = 'LS8'
```

- 2) it is allowed to have several different tables with permissible support loads in the same dp5 file

### Examples:

```
SUP_LOADS table = "LISEGA2010RSENR2"
& mode = 'NOC', load = 'LC4'
& mode = 'NOC+OBE', load = 'LS11'
SUP_LOADS table = "TITAN-2_R1_7"
& mode = 'NOC', load = 'LC5'
& mode = 'ANOC', load = 'LC4'
& mode = 'NOC+SSE', load = 'LS3'
```

## Export of piping Supports Loads to LICAD (DP2LCD)

The DP2LCD command is used to specify parameters for exporting a set of loads from dPIPE to [LICAD](#)<sup>®</sup>. See [Appendix XVI](#).

**Type:** general multi-line command

### Parameters:

#### LCD\_VER

LICAD version.

type: [TEXT](#)

units: -

default value: LICAD\_RS\_EN

limitations: 'LICAD\_RS\_EN' or 'LICAD\_10'

#### ANGLE

The permissible angle of deflection of the support from the direction of the axes perpendicular to the axis of the pipe. If the deviation is exceeded, the program gives a warning or error.

type: [REAL](#)  
 units: degree.  
 default value: 2.5°  
 limitations:  $\geq 0^\circ; \leq 30^\circ$

**SH\_MODE** Mode set in the LICAD for selection of the springs

type: [TEXT](#)  
 units: -  
 default value: 'COLD'  
 limitations: 'COLD' or 'HOT'

*SH\_MODE parameter defines the way how LICAD will treat spring hanger load. If the COLD mode is defined, then HOT loads will be recalculated through the spring stiffness and vertical travel. This value should corresponds to the LICAD settings*

**SKIP** Control of the support's data to be exported from dPIPE to LICAD

type: [TEXT](#)  
 units: -  
 default value: 'STRICT'  
 limitations: 'KKS'; 'DP5'; 'STRICT'; 'OFF'

*SKIP may have the following values*

**KKS** – Export for only supports having KKS identification

**DP5** – Export for only supports having output according to dPIPE rules (see [SKIP\\_SUP](#) and [SUP\\_SKIP](#))

**STRIC** – both KKS and DP5 rules are applicable + checking if supports are located in the nodes  
**T** belonged to pipes

**OFF** – all checks are disabled, loads for all supports are exported

**S\_CAT** seismic category of piping

type: [TEXT](#)  
 units: -  
 default value: 'I'  
 limitations: 'I'; 'II'; 'III'

#### Sub-command parameters:

**TYPE** predefined type of loads

type: [TEXT](#)  
 units: -  
 default value: -  
 limitations: depends on [LCD\\_VER](#), see [Appendix XVI](#)

**LOAD** Combination of loads for output

type: [TEXT](#)  
 units: -  
 default value: -  
 limitations: See Note (1)

**SF** amplification factors compatible with used Code

type: [REAL](#)  
units: -  
default value: 1.  
limitations: > 0, see. Notes (2)

**NOTE** Note/Comment

type: [STRING](#)  
units: -  
default value: -  
limitations: -

Sample:

```
DP2LCD lcd_ver = 'LICAD_10', skip = 'OFF', sh_mode = 'COLD', angle =  
2.5, s_ctg = 'I'  
&      'COLD' "LC6" note = "COLD"  
&      'HOT' "LC4" note = "HOT"  
&      'Test' "LC7" note = "TEST"  
&      'Level_AB' "LC1" SF 1  
&      'Level_C' "LD1 + LS11" sf = 1.6 note = "C1"  
&      'Level_D' "LD1 + LS18" sf = 1.7 note = "D1"
```

Notes:

1. The LOAD parameter can refer on any already existing Load Cases (including Dynamic Cases): LC&LD or on the Load Set with type 'SUPP'. For types that include seismic loads, it has to be combined with an appropriate static Load Case (Load Set)..
2. SF parameter is applicable only for export to LICAD-10 (LCD\_VER = 'LCD\_VER\_10'), see also [Appendix XVI](#)

## Managing the databases (DBF)

The DBF command determines the location of databases to be used by the program:

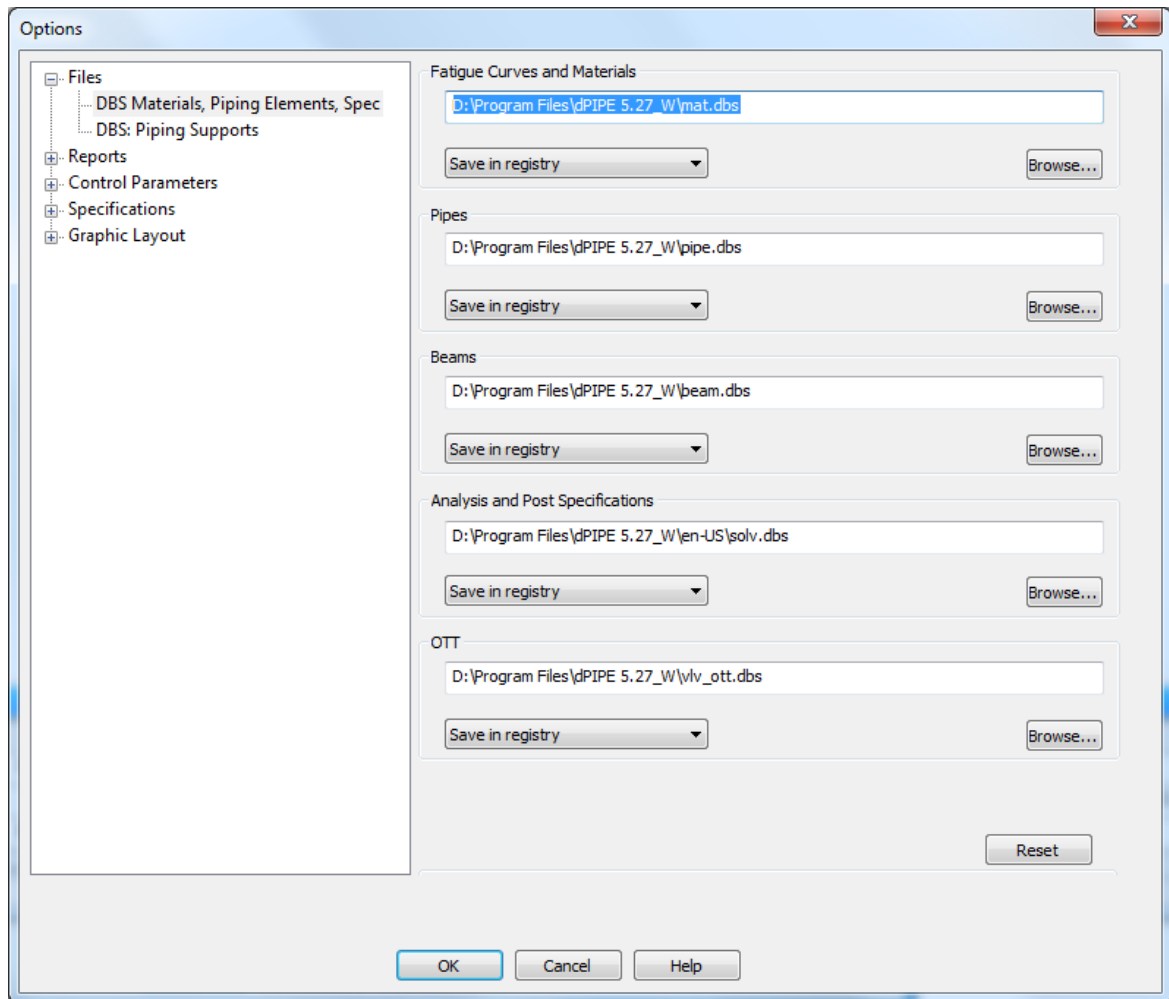

User can manage the paths to database files depending upon the options selected:

- in case of the **"Save in the register"** option being selected, the paths to databases will be recorded in the system register and connected automatically at the following session;
- in case of the **"Save in a file"** option being selected, the paths to databases will be stored in the <model name>.dp5 file and become active upon opening the existing model;
- in case of the **"Save relative paths in a file"** option being selected, the paths to databases will be recoded as relative links, otherwise the full paths will be written, which can cause problems when the model is transferred to another computer.

**type:** general one-line command

**Parameter subcommands:**

<b>SPR</b>	path to file containing the spring database;
<b>MAT</b>	path to file containing the materials database;
<b>PIPE</b>	path to file containing the pipe and bend database;
<b>BEAM</b>	path to file containing the beam database;
<b>DAMP</b>	path to file containing the damper database;
<b>SOLV</b>	path to file containing the database of the specifications for analysis and post-processing of the results;
<b>VALVES</b>	path to file containing the database of the permissible loads on valve nozzles;
<b>SUPLOAD</b>	path to file containing the database of the permissible loads on piping system supports;

**PRE\_FMT** path to file with template used for input data listing file (file \*.OUT);  
**POST\_FMT** path to file with template used for files with analyses results (files \*.RES and \*.SUP).

type: [STRING](#)  
 unit: -  
 default value: [blank](#)  
 limitations: The line length shall not exceed 259 characters.

Parameters *PRE\_FMT* and *PST\_FMT* are set in the window [Options/Report/Templates](#)

Example:

```
DBF
& spr = "D:\Program Files\dPIPE 5\sh.dbs"
& mat = "D:\Program Files\dPIPE 5\mat.dbs"
& pipe = "D:\Program Files\dPIPE 5\pipe.dbs"
& beam = "D:\Program Files\dPIPE 5\beam.dbs"
& damp = "D:\Program Files\dPIPE 5\dmp.dbs"
& solv = "D:\Program Files\dPIPE 5\solv.dbs"
& valves = "v\y_ott.dbs"
& supload = "D:\DBS\sup_ids.mdb"
```

## Suppressing results by headers (\$NOHEAD)

The \$NOHEAD command suppresses the printing of summary tables, in accordance with headers initiated by [NAME](#) commands. Simultaneously, it maintains the segmentation of the model by headers when browsing in PIPE3DV. Consequently, summary tables are printed for the entire model, excluding sections designated as 'boundary conditions,' which are addressed by the [SKIP\\_STR](#) command.

## Stress calculation Saf without allowable stress data (\$SAF\_ALLW)

The \$SAF\_ALLW command allows calculating SAF stress amplitudes when fatigue strength curve data are unavailable. The command is used for codes CODE = 'PNAE'/'GOST-59115-A'. When this command is used, zero values will appear in the allowable stress column in printouts. The command does not affect the [FATG](#) command.

## End of input data (END\_OF\_DATA)

The **END\_OF\_DATA** command limits the input data in the \*.dp5 file. All information following this command will be ignored by the program.

## Local Commands

There are two types of dPIPE Local commands: commands that define piping spatial layout, so called "geometrical" commands, and commands that define data related to the node.

The piping system geometry is determined by means of successive chain of the geometrical commands. One such continuous chain generates a **branch** of the piping. Each branch begins by the FROM command. A straight piping segment between two nodes, in which the direction is set in the explicit form, is called a **span**. Branch can be looped. All elements located within the same span shall have the nonzero length, except cases specially stated.

In order to determine geometry of the piping system, it is possible to use either Cartesian or spherical coordinate system. Each element of the analysis model has the direction and the length. The DC or DS parameter are used for setting the direction. The DC parameter is an array of three numbers setting the direction of the element axis in the Cartesian coordinate system. As the values of this array, the projections of the element (or span of the piping system onto the global XYZ coordinates or its directional cosines are specified (Fig. 2). In addition, by means of the DC parameters the length of span of the piping system can be determined:

$$LEN = \sqrt{DC(1)^2 + DC(2)^2 + DC(3)^2}$$

In doing so, it is permitted to avoid determining the length of one of the elements in the span; at that it will be computed as the difference between the LEN value and the sum of length of the remaining elements (the exception are elements that can have zero length: cold spring "[CS](#)" element and flexible joint element, [FJ](#)).

Example:

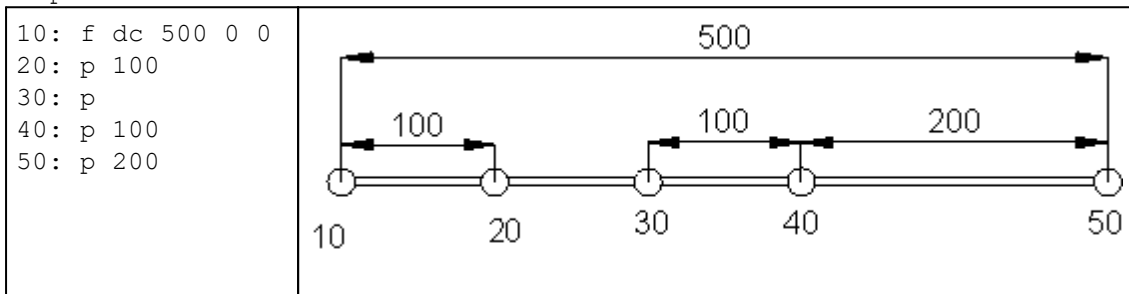

In this example the length of element 20 – 30 is automatically computed as  $500 - (100 + 100 + 200) = 100$

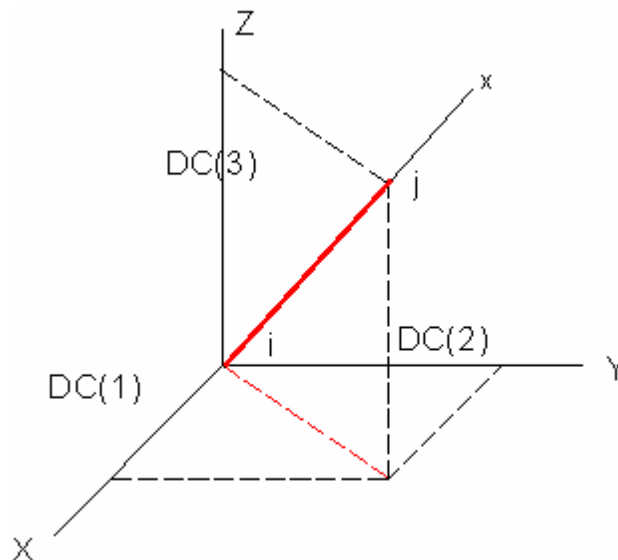

**Determination of the element direction in the Cartesian coordinate system**

DS being a similar parameter defines the direction of the element (piping segment) in the spherical coordinate system. In doing so, the first element of the array, DS(1), corresponds to the azimuth, i.e. to the angle in degrees between the global OX axis and the element projection onto the horizontal plane XOY. The positive direction of the angle is counted from the global OX axis to the horizontal projection of the element in the counterclockwise direction. The second element of the array, DS(2),

defines the slope, i.e. the angle between the axis of the element and its projection onto the horizontal plane. The positive direction is counted from the horizontal projection of the element upwards to the element axis. The third value of the DS parameter can determine the span length.

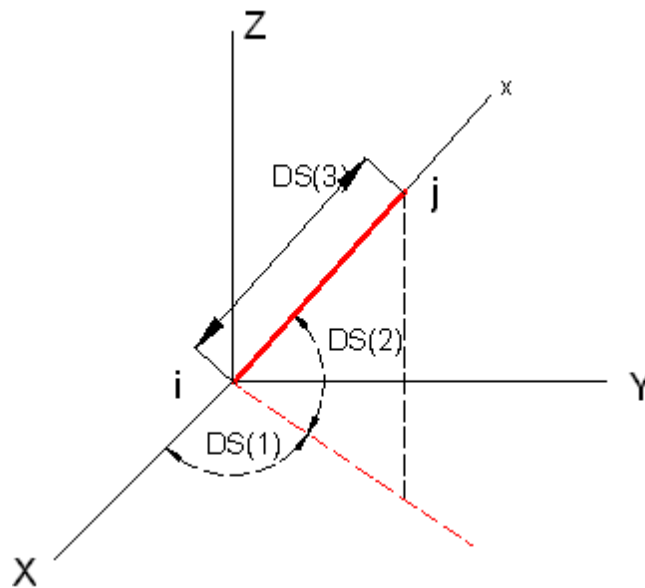

#### Determination of the element direction in the spherical coordinate system

The syntax of DC and DS parameters is common for all local commands and is given below:

**DC(3)** - setting the direction of the current span in Cartesian coordinates

type:	<a href="#">REAL</a>
unit:	either non-dimensional parameter or dimensional (in mm), if the span length is determined (see general notes)
dimension:	array of 3 elements
default value:	-
limitations:	all three elements of the array cannot simultaneously be equal to zero

**DS(3)** - setting the direction of the current span in spherical coordinates

type:	<a href="#">REAL</a>
unit:	the first and the second elements of the array are degrees, the last element is the length of span in mm (see general notes)
dimension:	array of 3 elements
default value:	0 0 0
limitations:	$DS(3) \geq 0$

Note:

*The DC and DS parameters can appear in almost any geometrical command. The exceptions are the [Bend \(2\)](#) element as well as any elements following the [Bend \(1\)](#) element. If it is required to set a new direction immediately after the bend, the User should begin a new branch:*

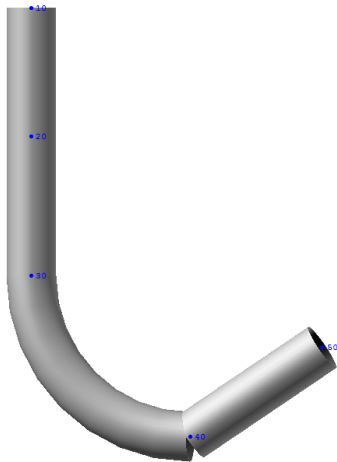
	<p>WRONG:</p> <p>10: F dc = 1, 1000, 0, cs = 'Pipe1', lg = 'LG1'  20: P  30: B r = 300, dc = -1, 0, 0  40: P dc = -1000, 500, 0.5, cs = 'Pipe1', lg = 'LG1'</p>
	<p>CORRECT:</p> <p>10: F dc = 1, 1000, 0, cs = 'Pipe1', lg = 'LG1'  20: P  30: B r = 300, dc = -1, 0, 0  30: F dc = -1000, 500, 0.5, cs = 'Pipe1', lg = 'LG1'  40: P</p>

The last limitation has been introduced into the program since Version 5.20 (July 2010). In case when old models are opened, which were created in the previous versions of the program, the following warning will appear:

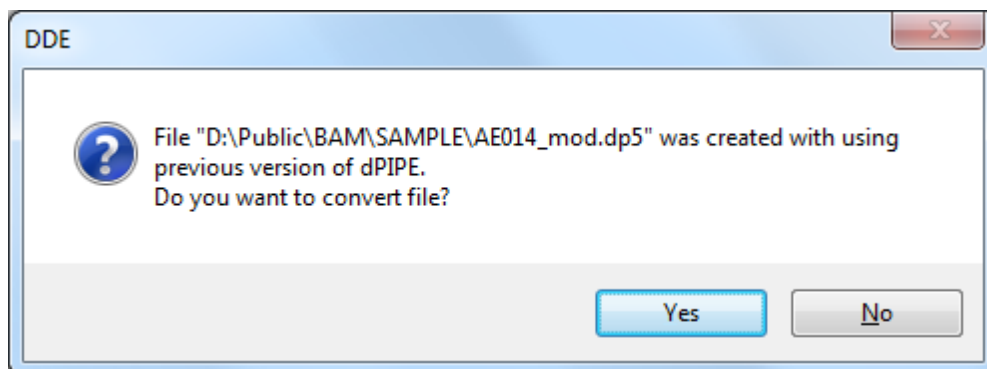

Similar commands are also used for one-directional restraints:

**DC/DS/DIRL(3)** - direction of the action of restraint in Cartesian/spherical or local coordinates.

**DC** is set in the form of an array of three numbers with projections of the axis of action of the restraint onto the global axes (for example, DC = 0, 1, 2), or if the line of action of the restraint coincides with one of the global axes, then the following short form is possible: DC = 'X' ('Y', 'Z')

**DS** defines the direction of the line of action of the restraint in spherical coordinates. It is set in the form of an array of two numbers, i.e. angles in degrees in the horizontal and vertical planes (see the similar command [DS](#), which is used for entering the piping system geometry)

**DIRL** is set in the form of an array of three numbers with projections of the axis of action of the restraint onto the local axes of the piping segment (for example, DIRL = 0, 1, 1), or if the line of action of the restraint coincides with

one of the local axes, then the following short form is possible: DIRL = 'A' ('H', 'N')

[From \(F\)](#)

[Straight pipe \(P\)](#)

[Bend-1 \(B\)](#)

[Bend-2 \(B\)](#)

[Miter bend \(MTR\)](#)

[Reducer \(R\)](#)

[Valve \(V\)](#)

[Angle valve \(V1, V2 command\)](#)

[Expansion joint \(EJ\)](#)

[Axial expansion joint \(EA\)](#)

[Tied expansion joint \(ET\)](#)

[Hinge expansion joint \(EH\)](#)

[Gimbal expansion joint \(EG\)](#)

[Rigid link \(RX/RP\)](#)

[Flexible element \(FJ\)](#)

[Cold spring \(CS\)](#)

[Structural element \(beam\) \(S\)](#)

[Locate position \(POS\)](#)

[Tee \(TEE\)](#)

[Welding \(WLD\)](#)

[Weight \(CW\)](#)

[Force \(FOR\)](#)

[Anchor \(ANC\)](#)

[Support \(SUP\)](#)

[Transverse restraint \(STS\)](#)

[Skewed restraint \(SRS\)](#)

[One-way restraint \(STS+, STS- commands\)](#)

[Guide support \(STG, STG-\)](#)

[Spring hanger/spring support \(SPR\)](#)

[Rod hanger \(ROD\)](#)

[Damper \(DMP\)](#)

[Snubber \(SNUB\)](#)

[Dynamic one-way restraint \(DGAP\)](#)

[Dynamic transient force \(DFRC\)](#)

[Time history output/travel indicator \(TH\\_OUT\)](#)

[Discontinuity stress \(STR\\_DISC\)](#)

### Initialization parameters

Initialization parameters are combined with local geometrical commands describing the piping layout

Command	Description	Allowable values	Default values	Notes
CS	Initialization of the piping Section	Reference on the names predefined by <a href="#">PIPE</a> or <a href="#">BEAM</a> commands	-	(1), (2)
LG	Initialization of the Load Group	Reference on the names predefined by LG parameters of <a href="#">OPVAL</a> command	-	(1), (2)
NAME	Identification name of the piping segment	String with length up to 32 symbols	-	(3)
CLS	Safety Class of the piping segment (applicable for ASME NB/NC Code)	cls = 1 or cls = 2	2	(2)
SBP	Small Bore Pipes marker	sbp = 'yes', sbp = 'no'	'no'	(2)
SCTG	Seismic Category (applicable for PNAE and GOST Codes)	sctg = 'I' or 'II' or 'III'	'N/A'	(2)

Notes:

- (1) The command has to be located at the beginning of the branch ([FROM](#) command)
- (2) Initializes the current piping segment up to the end of the branch, or until the next command
- (3) Initializes the current piping segment up to the next command. The command allows to assign a logical names to piping sections for subsequent partial display of the model and printing of the main calculation results for the selected sections at the end of the file with a printout of the

results (\*.res). The effect of this command on the entire model can be suppressed using the command \$NOHEAD = 'YES'

## From (F)

**type:** local geometrical command

**Function:** determines the first point of the Branch

### Parameters:

**DC or DS:** see "[Local commands](#)" section for the description of parameters

**CS** initialize the cross-section type

type:	<a href="#">TEXT</a>
unit:	-
default value:	mandatory parameter if the current cross-section is not initialized. Otherwise it takes the value of the current cross-section.
limitations:	the cross-section shall be preliminarily described by the <a href="#">PIPE</a> command or <a href="#">BEAM</a> command

**LG** initialize the load group

type:	<a href="#">TEXT</a>
unit:	-
default value:	mandatory parameter if the load group is not initialized. Otherwise it takes the value of the current load group.
limitations:	the load group shall be preliminarily described by one of the "LG" subcommands of the <a href="#">OPVAL</a> command

**NAME** - identification name of the piping segment

type:	<a href="#">STRING</a>
unit:	-
default value:	blank line or current identification name
limitations:	see limitations for the string values of parameters, the length shall not be more than 32 characters

**SBP** feature defines segment of the piping as "small bore pipe" (initialization parameter)

type:	<a href="#">TEXT</a>
unit:	-
default value	'NO'
limitations:	'YES', 'NO'

Example:

```
1000: F DC 0 0 1 CS '108x10' LG 'Line1' name = "Line 1"
```

or:

```
1000: F 0 0 1 '108x10' 'Line1' "Line 1"
```

## Straight pipe (P)

**type:** local geometrical command

**Function:** determines the "straight pipe" element

### Parameters:

**LEN** length of element

type:	<a href="#">REAL</a>
unit:	mm
default value:	0
limitations:	LEN ≥ 0

**DC or DS:** see "[Local commands](#)" section for the description of parameters

**CS** initialize the cross-section type

type:	<a href="#">TEXT</a>
unit:	-
default value:	mandatory parameter if the current cross-section is not initialized. Otherwise it takes the value of the current cross-section.
limitations:	the cross-section shall be preliminarily described by the <a href="#">PIPE</a> command

or:

**XS** change of the cross-section type only for the current element without changing the current value for the whole remaining segment

type:	<a href="#">TEXT</a>
unit:	-
limitations:	the cross-section shall be preliminarily described by the <a href="#">PIPE</a> command

**LG** initialize the load group

type:	<a href="#">TEXT</a>
unit:	-
default value:	mandatory parameter if the load group is not initialized. Otherwise it takes the value of the current load group
limitations:	the load group shall be preliminarily described by one of the "LG" subcommands of the <a href="#">OPVAL</a> command

**NAME** - identification name of the piping segment

type:	<a href="#">STRING</a>
unit:	-
default value:	blank line or current identification name
limitations:	see limitations for the string values of parameters, the length shall not be more than 32 characters

**SBP** feature that defines the element and following portion of the piping as "small bore pipe" (initialization parameter), see [SBP](#)

Example:

```
2000: P 2300 DC 1 CS '108x10' LG 'Line1'
```

or:

```
2000: P 2300 DC 1 0 0 CS '108x10' LG 'Line1'
```

## Bend-1 (B)

**type:** local geometrical command

**Function:** determines the element for modeling the curved pipe (bend or elbow)

**Parameters:**

**ID<sup>1)</sup>** - identification name of the bend determined by the [BEND](#) subcommand of the PIPE general command

type:	<a href="#">TEXT</a>
unit:	-

default value: -  
 limitations: the name shall be preliminarily described by the [BEND](#) subcommand of the PIPE command

or

**R<sup>2</sup>**) radius of bend

type: [REAL](#)  
 unit: mm  
 default value: -  
 limitations:  $R > 0$ ; the bend shall adjust to the geometry of the segment (see Example of setting the geometry in the ["Local commands" section](#))

**DC or DS**: see ["Local commands" section](#) for the description of parameters. The parameters determine the direction of span being next to the bend. The direction of the BEND element shall differ from the current direction (see Example of setting the geometry)

**XS<sup>1</sup>**) set the type of the cross-section used for BEND if it differs from the cross-section of the adjacent pipe

type: [TEXT](#)  
 unit: -  
 default value: current cross-section type  
 limitations: the cross-section shall be preliminarily described by the [PIPE](#) command

**LG** initialize the load group

type: [TEXT](#)  
 unit: -  
 default value: current load group  
 limitations: the load group shall be preliminarily described by one of the "LG" subcommands of the [OPVAL](#) command

**OVAL** out-of-roundness (ovality) of the cross-section (this parameter redefines the similar value that is set in the [BEND](#) subcommand of the [PIPE](#) general command)

type: [REAL](#)  
 unit: %  
 default value: 0 or value defined by the OVAL parameter in the [BEND](#) subcommand of the [PIPE](#) general command  
 limitations:  $0 \leq \text{OVAL} \leq 100$

**SMIN** minimum thickness of the bend wall (this parameter redefines the similar value that is set in the [BEND](#) subcommand of the [PIPE](#) general command)

type: [REAL](#)  
 unit: mm

default value: value defined by the SMIN parameter in the [BEND](#) subcommand of the PIPE general command  
 limitations: [see note \(6\) to the PIPE command](#)

**FLEX** flexibility factor of curvilinear pipe, which is used in generating the stiffness matrix of the element

type: [REAL](#)  
 unit: -  
 default value: it is computed by the program automatically depending upon the Analysis codes being used.  
 limitations:  $FLEX \geq 1$ .

**FLNG** number of flanges at the ends of the bend (available only for [CODE](#) = 'ASME\_B311')

type: [INTEGER](#)  
 unit: -  
 default value: 0  
 limitations: 0, 1, 2

**XT** wall thickness correction factor

type: [REAL](#)  
 unit: -  
 default value: 1  
 limitations:  $\geq 1$

**NAME** - identification name of the piping segment

type: [STRING](#)  
 unit: -  
 default value: blank line or current identification name  
 limitations: see limitations for the string values of parameters, the length shall not be more than 32 characters

**SBP** feature that defines the element and following portion of the piping as "small bore pipe" (initialization parameter), see [SBP](#)

When using ASME/EN CODES, an additional tab with [stress indexes](#) appears in the dialog

**Note:**

- 1) In setting the bend by means of the ID parameter, it is not allowed to use the XS parameter
- 2) designation "R" is mandatory
- 3) The full angle of bend shall be within the following range:  $BEND\_ANG < a < 180^\circ - BEND\_ANG$ :

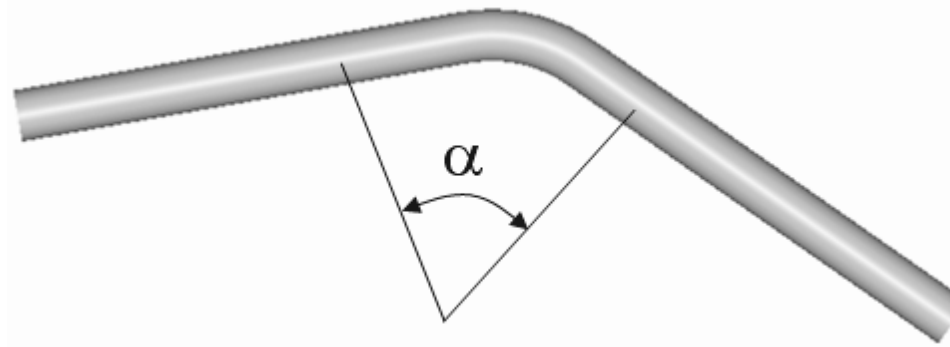

Example:

```
3000: b r 1000 dc 1 0 0 xs '108x12' OVAL 3 SMIN 10 FLEX 1.
```

or:

```
1000: b ID 'LONG'
```

## Bend-2 (B)

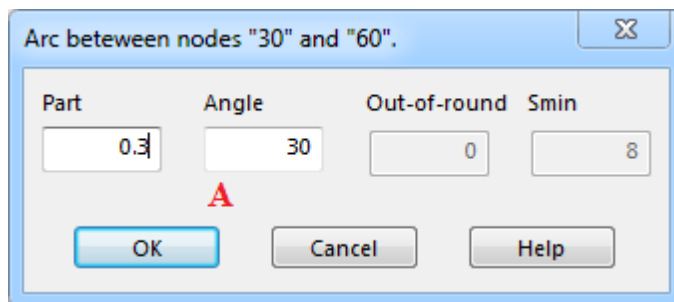

**type:** local geometrical command

**Function:** allows splitting one bend into several elements. It is used only in combination with the [BEND-1](#) command. The BEND-2 command shall precede the BEND-1 command.

**Parameters:**

**A<sup>1)</sup>** parameter of the division of a curved pipe into parts. At  $A > 1$  it defines the angle (in degrees) from the beginning of the bend to the current node. At  $0 < A \leq 1$  it defines a part of the full bending angle.

type:

**REAL**

unit:

degrees or non-dimensional parameter

default value:

-

limitations:

the angle cannot be more than the full angle of bend

**Note:**

1) designation "A" is mandatory

Example:

```

10: f 0 1 0 '108x5' 'Line1'
20: p 400
30: p 1150
40: b a 30
50: b a 60
60: b r 500 dc 0 0 1
70: p 1050

```

or:

```

10: f 0 1 0 '108x5' 'Line1'
20: p 400
30: p 1150
40: b a .33333
50: b a .66666
60: b r 500 dc 0 0 1
70: p 1050

```

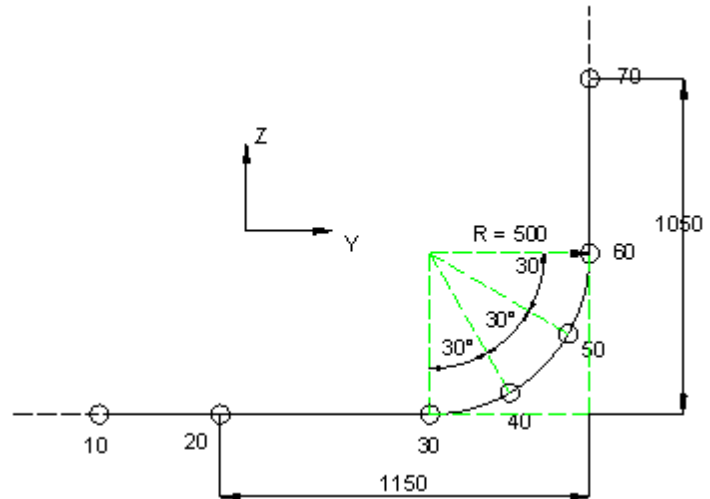

## Miter bend (MTR)

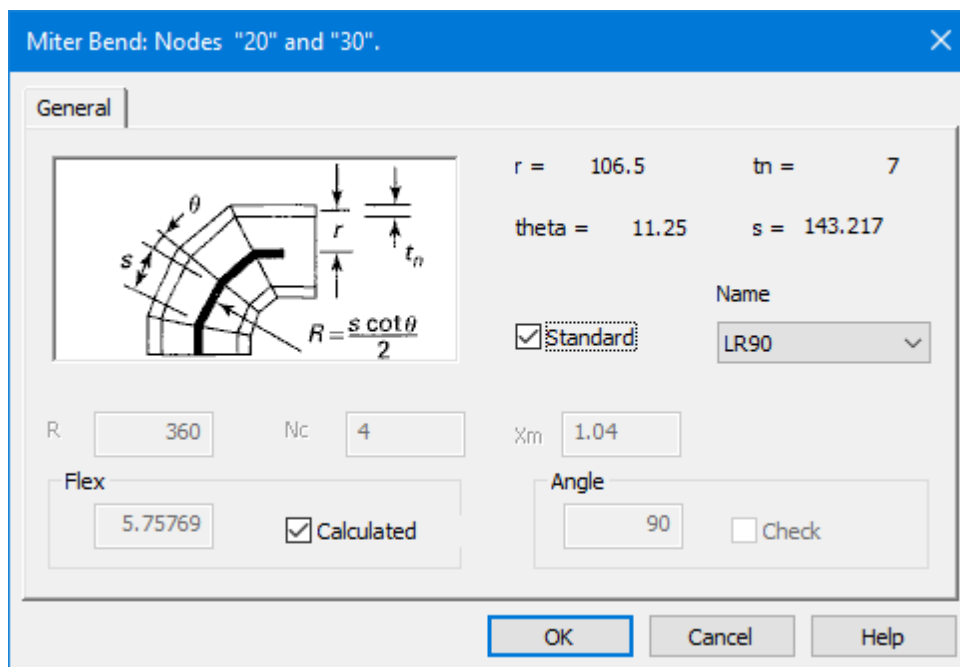

**type:** local geometrical command

**Function:** determines the "miter bend" element <sup>1)</sup>

### Parameters:

**ID<sup>1)</sup>** - identification name of the miter determined by the [MITR](#) subcommand of the PIPE general command

**type:** [TEXT](#)  
**unit:** -  
**default value:** -  
**limitations:** the name shall be preliminarily described by the [MITR](#) subcommand of the PIPE command

**R** equivalent radius of the miter bend

type: [REAL](#)  
 unit: mm  
 default value: -  
 limitations:  $R > 0$ ; the element shall adjust to the geometry of the segment (see Example of setting the geometry in the "[Local commands](#)" section)

**Nc** number of miter cuts

type: [INTEGER](#)  
 unit: -  
 default value: -  
 limitations:  $> 0$

**[XM](#)** weight correction factor;

type: [REAL](#)  
 unit: -  
 default value: 1  
 limitations:  $\geq 1$

**ANGLE** miter bend angle (is used to check geometry of the piping layout)

type: [REAL](#)  
 unit: degrees  
 default value: 0  
 limitations:  $\geq 0$

**DC or DS:** see "[Local commands](#)" section for the description of parameters. The parameters determine the direction of span being next to the bend. The direction of the BEND element shall differ from the current direction (see Example of setting the geometry)

**XS** setting the cross-section type for the bend, if it differs from the cross-section of the adjacent pipe

type: [TEXT](#)  
 unit: -  
 default value: current cross-section type  
 limitations: the cross-section shall be preliminarily described by the [PIPE](#) command

**LG** initialize the load group

type: [TEXT](#)  
 unit: -  
 default value: current load group  
 limitations: the load group shall be preliminarily described by one of the "LG" subcommands of the [OPVAL](#) command

**FLNG** number of flanges at the ends of the bend (available only for [CODE](#) = 'ASME\_B311')

type: [INTEGER](#)  
 unit: -  
 default value: 0  
 limitations: 0, 1, 2

**NAME** - identification name of the piping segment

type: [STRING](#)  
 unit: -  
 default value: blank line or current identification name  
 limitations: see limitations for the string values of parameters, the length shall not be more than 32 characters

**SBP** feature that defines the element and following portion of the piping as "small bore pipe" (initialization parameter), see [SBP](#)

When using ASME/EN CODES, an additional tab with [stress indexes](#) appears in the dialog

See also [Appendix XIX](#) on modeling miter bends in dPIPE

**Note:**

- 1) In setting the miter by means of the ID parameter, it is not allowed to use the XS parameter
- 2) The "Miter bend" element is a variation of the "Bend" element and is mainly used within the framework of analysis according to international codes (ASME, EN) for specification of the flexibility factor and stress indexes. When the element is set within the analysis according to Russian Codes (PNAE or RD) the program will interpret it as a conventional bend with radius  $R$  and specified characteristics of the cross-section.

To define the element one should set an equivalent radius  $R$  and number of cuts  $N_c$ :

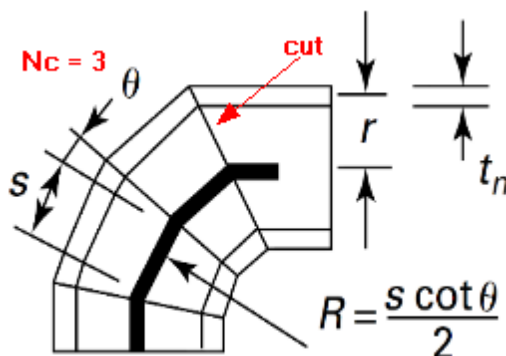

If  $N_c = 1$ , it's assumed that the miter bend is designed as a connection of two half-miters (Miter Joint). In this case, its radius ( $R$ ) will be redefined by the program based on the relationship:  $R_e = 0.5 * r * (1 + \cot(\theta))$ , where:  $r$  – mean pipe radius,  $\theta$  – half of the full bend angle. If  $N_c > 1$ , then  $\theta = \alpha / (2 * N_c)$ , and the sector length  $s = 2 * R_e * \tan(\theta)$ .

Check for Errors:

1.  $R > D/2$
2.  $B = s \cdot (1 - r_0/R_0) \geq 5 \cdot t$  ( $r_0$  - outside pipe radius,  $t$  - wall thickness)
3. For ASME B31.1:  $B > 6t$

Program will issue the warnings, if:

- 1) the total miter bend's angle  $\alpha$  is less than  $15^\circ$ ;
- 2) angle  $\theta > 15^\circ$  (for Russian PNAE and RD Codes);
- 3) angle  $\theta > 22.5^\circ$  (for the rest of Codes (except PNAE and RD)
- 4) angle  $\theta < 1.5^\circ$
- 5)  $R < A/\tan(\theta) + D/2$ , where:

$$A = \begin{cases} 25.4 & \text{if } t \leq 17.7 \\ 2t & \text{if } 17.7 < t < 22.35 \text{ (all data in mm)} \\ (2t/3) + 29.8 & \text{if } t \geq 22.35 \end{cases}$$

3) when specifying a miter bend using the ID parameter, use of the XS parameter is not allowed

Example:

```
30: MTR r = 862.089, nc = 2, ds = 45, 0, 5000, xs = 'Pipe2', name = "LAB10"
```

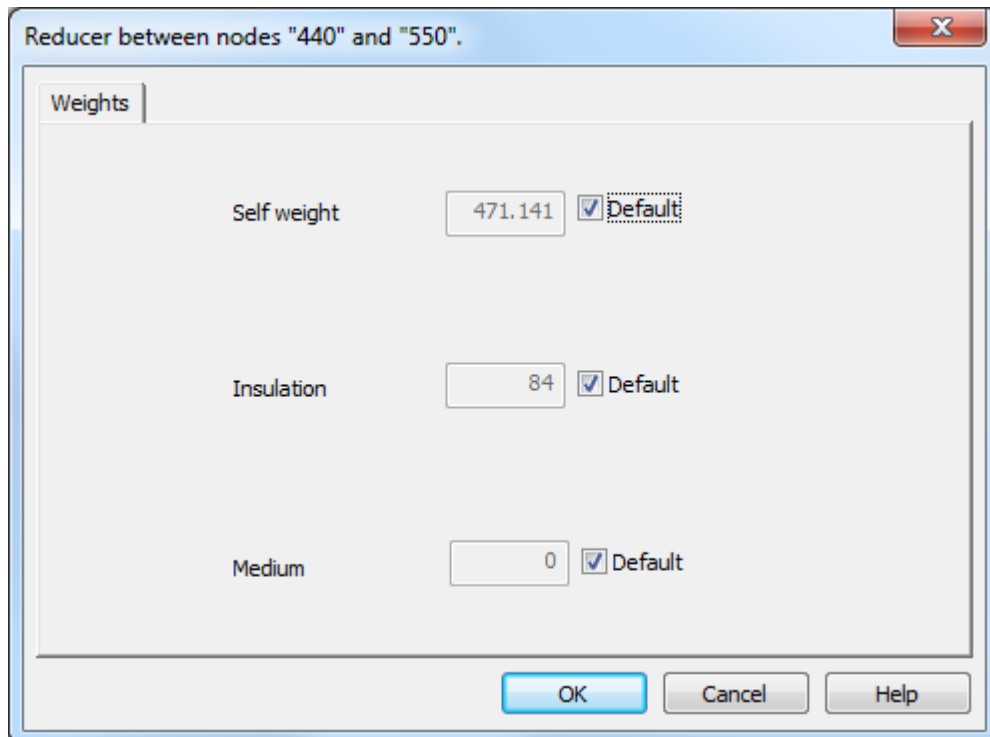
**Reducer (R)**

**type:** local geometrical command

**Function:** determines the Reducer element between pipes of various diameter. The stiffness matrix of the element is formed as for the "straight pipe" element with averaged characteristics of the cross-section from the adjacent pipes.

**Parameters:**

**LEN** length of element

type:	<a href="#">REAL</a>
unit:	mm
default value:	0
limitations:	$\geq 0$

**ANGLE** cone angle (it is used for computation of the stress indexes in analysis according to international codes)

type:	<a href="#">REAL</a>
unit:	degrees
default value:	<a href="#">see Note 1</a>
limitations:	$\geq 0$

**MAT** - reference identification name of the material (see [MAT](#) command)

type:	<a href="#">TEXT</a>
unit:	-
default value:	-
limitations:	the name should coincide with the materials names determined earlier.

**DC** or **DS**: see ["Local commands" section](#) for the description of parameters

**CS** initialize the type of cross-section being next to the Reducer element

type:	<a href="#">TEXT</a>
unit:	-
default value:	mandatory parameter. Must define different cross-section in respect to adjacent pipe
limitations:	the cross-section shall be preliminarily described by the <a href="#">PIPE</a> command

**LG** initialize the load group

type:	<a href="#">TEXT</a>
unit:	-
default value:	mandatory parameter if the current load group is not initialized. Otherwise it takes the value of the current load group.
limitations:	the load group shall be preliminarily described by one of the "LG" subcommands of the <a href="#">OPVAL</a> command

**W(3)** weight characteristics of the element: see [Appendix IV](#).

type:	<a href="#">REAL</a>
unit:	Newton
default value:	all three components of the array are determined as average values from the characteristics of the adjacent pipes
dimension	array of 3 elements
limitations:	see <a href="#">Appendix IV</a> .

**TYPE** - reducer's type

type:	<a href="#">STRING</a>
unit:	-
default value:	'CONC'
limitations:	'CONC' - concentric reducer, 'ECCN' - eccentric reducer

**BETA** - orientation of the eccentric reducer relative to its axis (see [Example of setting](#))

type:	<a href="#">REAL</a>
unit:	degrees
default value:	0
limitations:	$ \text{BETA}  \leq 360$

**NAME** - identification name of the piping segment

type:	<a href="#">STRING</a>
unit:	-
default value:	blank line or current identification name
limitations:	see limitations for the string values of parameters, the length shall not be more than 32 characters

**SBP** feature that defines the element and following portion of the piping as "small bore pipe" (initialization parameter), see [SBP](#)

When using ASME/EN CODES, an additional tab with [stress indexes](#) appears in the dialog

**Note:**

- 1) By default **ANGLE** parameter is not defined. In this case a maximal values are used for stress indexes/stress intensification factors:  $B_1 = 1$ ,  $i = 2$

Example:

```
2000: r 400 CS '108x10' w 10
```

## Valve (V)

Valve between Nodes 150 and 160

Type: **General**

Show Scheme:

**V**

Loads from DB

Label 1: **9 OTT\_REF** Select...

Label 2: **OTT\_REF2** Select...

Weights

Body **W(1)**: 3000

Insulation **W(2)**: 1225  Default

Medium **W(3)**: 688.578  Default

Actuator Weight **WOP**: 5000

Actuator's Offset **OFF(1-3)**

dX: 0 dY: 0 dZ: 1 L **A\_LEN**: 400

Coordinates  Cosines

Material: **ST20**

Designation: **10KBA20AA602** **NOTE**

OK Cancel Help

The input window provides separate setting of the valve weights: e.g. weight of the valve body and the weight of the actuator. With the flags marked by default, the weight of insulation and piping content will be added to the element depending upon the characteristics of the adjacent pipe and the current load group. In doing so, the weight of insulation is calculated with the coefficient 1.75 of the pipe's weight, and the weight of the piping content is added to be equal to the weight of the working fluid in the straight pipe. The user can redefine these parameters having removed the flag marks taken by default. If a positive number is entered, then it will be taken by the program as weight (of insulation or piping content) in Newtons. In case of negative values being entered the program will take them as multipliers to the weight of insulation or working fluid. If the dead weight is set equal to zero, then the weight of insulation and working fluid will not be added to the element by default.

When setting the weight of actuator, it is mandatory to enter information about the offset of the center of mass of the actuator with respect to the central point of the element. The offset can be set either in relative coordinates ("Coordinates" flag) or by means of the direction cosines and the length of driver.

The "Loads from DB" field serves for selecting permissible loads in accordance with NP-068-05 "Valves for nuclear plants. General technical requirements".

The "Designation" field is used for setting the identification name of valves. This information is output for printing in listings of the input data and the results of analysis.

**type:** local geometrical command

**Function:** determines the element for the modeling of valves and similar pipe accessories. The stiffness matrix for an element is formed the same as for the "straight pipe" element of the current cross-section with the wall thickness being multiplied by the [V\\_STF](#) factor.

**Parameters:**

**LEN** length of element

type:	<a href="#">REAL</a>
unit:	mm
default value:	0
limitations:	LEN ≥ 0

**DC** or **DS:** see ["Local commands" section](#) for the description of parameters

**XS** set the cross-section type only for the current element without changing the current value for the rest of the segment

type:	<a href="#">TEXT</a>
unit:	-
default value:	mandatory parameter if the current cross-section is not initialized. Otherwise it takes the value of the current cross-section.
limitations:	the cross-section shall be preliminarily described by the <a href="#">PIPE</a> command

**LG** initialize the load group

type:	<a href="#">TEXT</a>
unit:	-
default value:	mandatory parameter if the load group is not initialized. Otherwise it takes the value of the current load group
limitations:	the load group shall be preliminarily described by one of the "LG" subcommands of the <a href="#">OPVAL</a> command

**W(3)** weight characteristics of the element<sup>1)</sup>

type:	<a href="#">REAL</a>
unit:	Newton
dimension:	array of three numbers
default value:	see <a href="#">Appendix IV</a> .
limitations:	-

**MAT** - reference identification name of the material (see [MAT](#) command)

type:	<a href="#">TEXT</a>
unit:	-
default value:	-

limitations: the name should coincide with the materials names determined earlier.

**WOP** weight of drive

type: [REAL](#)  
unit: Newton  
default value: 0  
limitations:  $WOP \geq 0$

**OFF(3)** relative coordinates of the center of mass of the drive or direction cosines (X, Y, Z)<sup>2)</sup>

type: [REAL](#)  
unit: mm  
dimension: array of three numbers  
default value: 0, 0, 0  
limitations: -

**A\_LEN** length of drive<sup>3)</sup>

type: [REAL](#)  
unit: mm  
default value: -  
limitations:  $A\_LEN > 0$

**NOTE** Note/Comment - identification name of the valve

type: [STRING](#)  
unit: -  
default value: [blank](#)  
limitations: see limitations for the string values of parameters, the length shall not be more than 32 characters

**NAME** - identification name of the piping segment

type: [STRING](#)  
unit: -  
default value: blank line or current identification name  
limitations: see limitations for the string values of parameters, the length shall not be more than 32 characters

**SBP** feature that defines the element and following portion of the piping as "small bore pipe" (initialization parameter), see [SBP](#)

**OTT\_REF** label identifying a record in the database with permissible loads on the valve nozzle from the side of first element's node (see [Appendix X](#))

type: [TEXT](#)  
 unit: -  
 default value: -  
 limitations: to be determined by the values being present in the  
 vlv\_ott.dbs file. The length shall not exceed 8  
 characters

**OTT\_REF2** label identifying a record in the database with permissible loads on the valve nozzle from the side of second element's node (see [Appendix X](#))

type: [TEXT](#)  
 unit: -  
 default value: -  
 limitations: to be determined by the values being present in the  
 vlv\_ott.dbs file. The length shall not exceed 8  
 characters

**Note:**

- 1) See [Appendix IV](#).
- 2) The coordinates are set in the global system combined with the center of mass of the valve housing. When the **A\_LEN** parameter is present, the values are interpreted as direction cosines.
- 3) The parameter is used only for setting the coordinates of the center of mass of the actuator by means of direction cosines.

**Example:**

```
30: V len = 800, w = 2000,,, wop = 1000, off = 0, 0, 1, a_len = 400, note = "RA250S
```

or:

```
30: V len = 800, w = 2000,,, wop = 1000, off = 0, 0, 400, note = "RA250S802", ott_1
```

## "Half-valve" (V1, V2 commands)

"Half-valve" is used to model different types of piping fittings. It is possible to set the left-side and right-side parts of the valve.

The input window provides setting of the valve weights: with the flags marked by default, the weight of insulation and piping content will be added to the element depending upon the characteristics of the adjacent pipe and the current load group. In doing so, the weight of insulation is calculated with the coefficient 1.75 of the pipe's weight, and the weight of the piping content is added to be equal to the weight of the working fluid in the straight pipe. The user can redefine these parameters having removed the flag marks taken by default. If a positive number is entered, then it will be taken by the program as weight (of insulation or piping content) in Newtons. In case of negative values being entered the program will take them as multipliers to the weight of insulation or working fluid. If the dead weight is set equal to zero, then the weight of insulation and working fluid will not be added to the element by default.

The "Loads from DB" field serves for selecting permissible loads in accordance with NP-068-05 "Valves for nuclear plants. General technical requirements".

The "Designation" field is used for setting the identification name of valves. This information is output for printing in listings of the input data and the results of analysis.

**type:** local geometrical command

**Function:** commands for the modeling different types of piping fittings, for example, angle valve. When valves are set by means of V1, V2 commands, the weight of valve shall be divided equally between these two elements.

### Parameters:

**LEN** length of element

type: [REAL](#)  
unit: mm

default value: 0  
 limitations: LEN ≥ 0

**DC** or **DS**: see "[Local commands](#)" section for the description of parameters

**XS** change the cross-section type only for the current element without changing the current value for the rest of the segment

type: [TEXT](#)  
 unit: -  
 default value: mandatory parameter if the current cross-section is not initialized. Otherwise it takes the value of the current cross-section.  
 limitations: the cross-section shall be preliminarily described by the [PIPE](#) command

**LG** initialize the load group

type: [TEXT](#)  
 unit: -  
 default value: mandatory parameter if the load group is not initialized. Otherwise it takes the value of the current load group .  
 limitations: the load group shall be preliminarily described by one of the "LG" subcommands of the [OPVAL](#) command

**W(3)** weight characteristics of the element<sup>1)</sup>

type: [REAL](#)  
 unit: Newton  
 dimension: array of three numbers  
 default value: see [Appendix IV](#).  
 limitations: -

**MAT** - reference identification name of the material (see [MAT](#) command)

type: [TEXT](#)  
 unit: -  
 default value: -  
 limitations: the name should coincide with the materials names determined earlier.

**NOTE** Note/Comment/- identification name of the valve

type: [STRING](#)  
 unit: -  
 default value: [blank](#)  
 limitations: see limitations for the string values of parameters, the length shall not be more than 32 characters

**NAME** - identification name of the piping segment

type: [STRING](#)  
 unit: -

default value: blank line or current identification name  
 limitations: see limitations for the string values of parameters, the length shall not be more than 32 characters

**SBP** feature that defines the element and following portion of the piping as "small bore pipe" (initialization parameter), see [SBP](#)

**OTT\_REF** label identifying a record in the database with permissible loads on the valve nozzles (see [Appendix X](#))

type: [TEXT](#)  
 unit: -  
 default value: -  
 limitations: to be determined by the values being present in the `vv_ott.dbs` file. The length shall not exceed 8 characters

**Note:**

- 1) See [Appendix IV](#).

Example:

```
2000: V1 1000 W 230 NOTE "Valve 30RAS201" DC 1 0 0
2000: V2 1000 W 230 NOTE "Valve 30RAS201" DC 0 0 -1
```

**Angle valve (VA)**

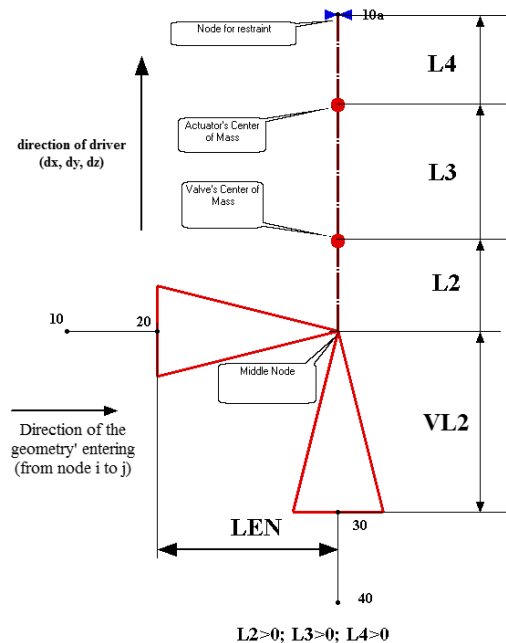
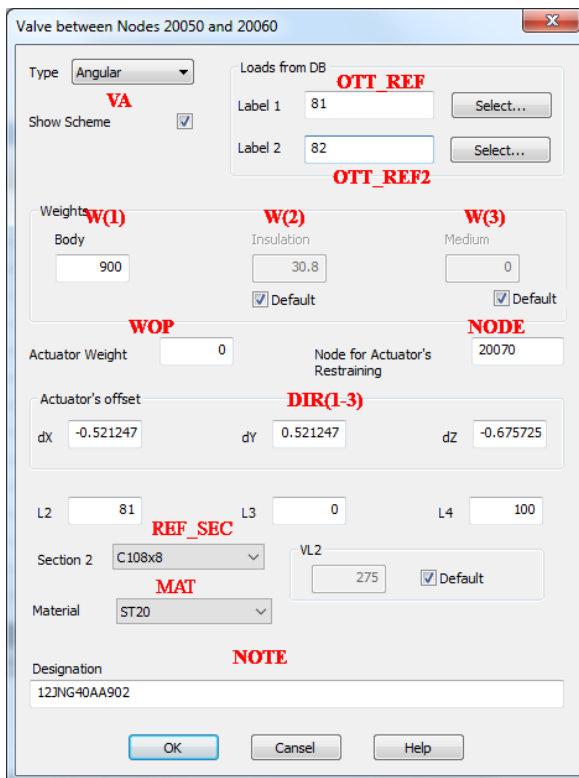

Calculation model of the angle valve

The "angle valve" changes the direction of the current branch. That is why the string where this element is present should have commands for change of direction. Caution: If the angle valve is adjacent to the Bend element his length should not be corrected on the projection of bend radius like it's doing for a straight pipe:

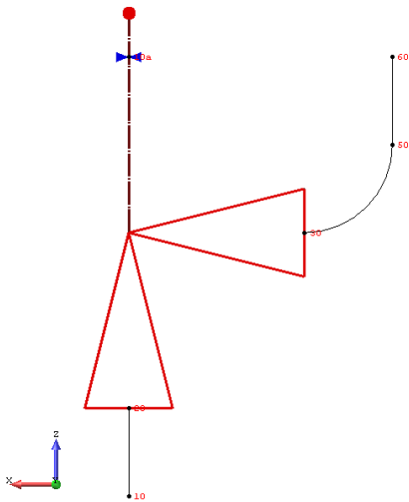

Layout							
	Node	Element	L/R	dX	dY	dZ	Add. Data
1	10	From		0	0	600	
2	20		0				
3	30	Valve	400	-600	0	0	Restraint
4	50	Bend	200	0	0	1	
5	60		400				

Element's dialog allows to set points for the Valve's center of mass, center of mass of the actuator and the node, at which the drive restraining is possible ("Node for Actuator's restraining" field). It is supposed that these points lie on the same line, which direction is determined by means of direction cosines in the "Actuator's offset" field. The distance to the points specified is measured from the central point of the element according to the dimension chaining principle. Below the examples are given for determination of L2 - L4 parameters depending upon location of the points being determined.

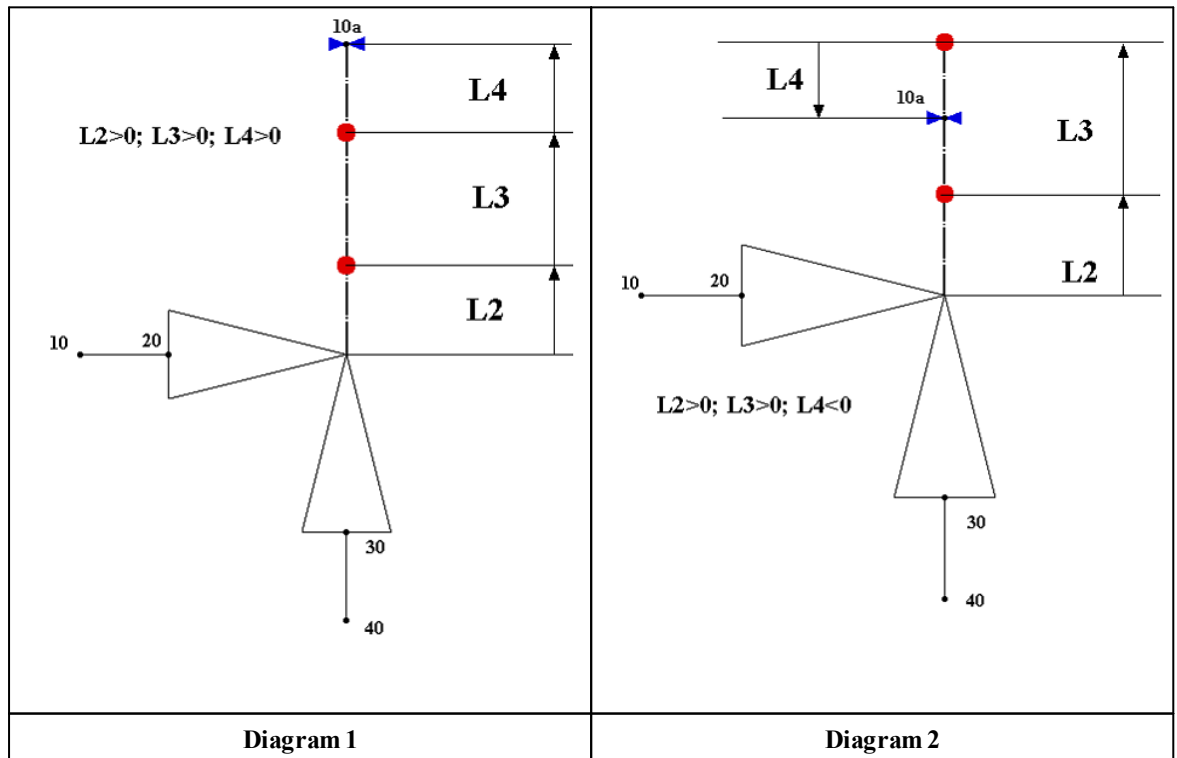

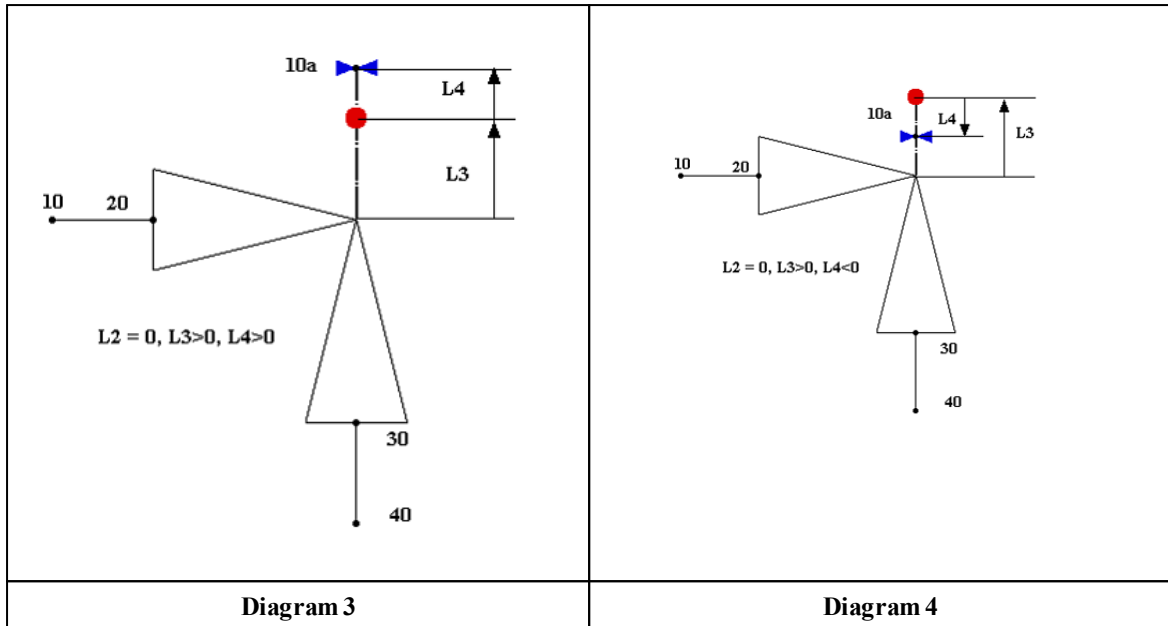

To set the supports in node 10a, it is necessary to call the "additional data" dialog (in the same line where the element is described) and transfer to the tab with the name of this node:

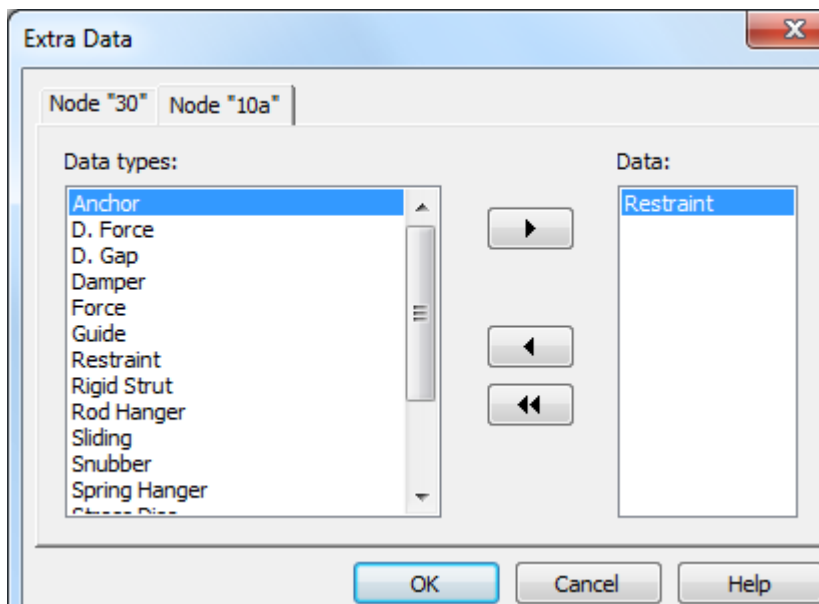

The input window provides separate setting of the valve weights: e.g. weight of the valve body and the weight of the actuator. With the flags marked by default, the weight of insulation and piping content will be added to the element depending upon the characteristics of the adjacent pipe and the current load group. In doing so, the weight of insulation is calculated with the coefficient 1.75 of the pipe's weight, and the weight of the piping content is added to be equal to the weight of the working fluid in the straight pipe. The user can redefine these parameters having removed the flag marks taken by default. If a positive number is entered, then it will be taken by the program as weight (of insulation or piping content) in Newtons. In case of negative values being entered the program will take them as multipliers to the weight of insulation or working fluid. If the dead weight is set equal to zero, then the weight of insulation and working fluid will not be added to the element by default.

The "Loads from DB" field serves for selecting permissible loads in accordance with NP-068-05 "Pipeline valves for nuclear plants. General technical requirements".

The "Designation" field is used for setting the identification name of valves. This information is output for printing in listings of the input data and the results of analysis.

**type:** local geometrical command

**Function:** determines the element for the simulation of valves and fittings (slides, gates, valves, etc.). The stiffness matrix for an element is formed the same as for the "straight pipe" element of the current cross-section with the wall thickness being multiplied by the [V\\_STF](#) factor.

**Parameters:**

**LEN** length of element (see the analytical model of the valve)

type:	<a href="#">REAL</a>
unit:	mm
default value:	0
limitations:	$LEN \geq 0$

**DC or DS:** see ["Local commands" section](#) for the description of parameters. **For the angle valve the entry of these parameters is mandatory!**

**XS** change the cross-section type only for the current element without changing the current value for the rest of the segment

type:	<a href="#">TEXT</a>
unit:	-
default value:	mandatory parameter if the current cross-section is not initialized. Otherwise it takes the value of the current cross-section.
limitations:	the cross-section shall be preliminarily described by the <a href="#">PIPE</a> command

**LG** initialize the load group

type:	<a href="#">TEXT</a>
unit:	-
default value:	mandatory parameter if the load group is not initialized. Otherwise it takes the value of the current load group.
limitations:	the load group shall be preliminarily described by one of the "LG" subcommands of the <a href="#">OPVAL</a> command.

**W(3)** weight characteristics of the element<sup>1)</sup>

type:	<a href="#">REAL</a>
unit:	Newton
dimension	array of three numbers
default value:	see <a href="#">Appendix IV</a> .
limitations:	-

**MAT** - reference identification name of the material (see [MAT](#) command)

type:	<a href="#">TEXT</a>
unit:	-
default value:	-

limitations: the name should coincide with the materials names determined earlier.

**WOP** weight of drive

type: [REAL](#)  
 unit: Newton  
 default value: 0  
 limitations:  $WOP \geq 0$

**DIR(3)** direction cosines for determination of the drive direction

type: [REAL](#)  
 unit: mm  
 dimension: array of three numbers  
 default value: 0, 0, 0  
 limitations: -

**LEN2, LEN3, LEN4** distances determining the center of mass of the housing, center of mass of the actuator and the drive restraining point (see Fig. with the analytical model).

type: [REAL](#)  
 unit: mm  
 default value: -  
 limitations: -

**VL2** length of the second part of the valve (see Fig. with the analytical model)

type: [REAL](#)  
 units: mm  
 default value: LEN  
 limitations: -

**NODE<sup>2)</sup>** name of the node for detachment of the drive

type: [TEXT](#)  
 unit: -  
 default value: -  
 limitations: see limitations for [node labels](#)

**NOTE** Note/Comment/- identification name of the valve

type: [STRING](#)  
 unit: -  
 default value: [blank](#)  
 limitations: see limitations for the string values of parameters, the length shall not be more than 32 characters

**NAME** - identification name of the piping segment

type: [STRING](#)  
 unit: -

default value: blank line or current identification name  
 limitations: see limitations for the string values of parameters,  
 the length shall not be more than 32 characters

**SBP** feature that defines the element and following portion of the piping as "small bore pipe" (initialization parameter), see [SBP](#)

**OTT\_REF** label identifying a record in the database with permissible loads on the valve nozzle from the side of first element's node (see [Appendix X](#))

type: [TEXT](#)  
 unit: -  
 default value: -  
 limitations: to be determined by the values being present in the  
 vlv\_ott.dbs file. The length shall not exceed 8  
 characters

**OTT\_REF2** label identifying a record in the database with permissible loads on the valve nozzle from the side of second element's node (see [Appendix X](#))

type: [TEXT](#)  
 unit: -  
 default value: -  
 limitations: to be determined by the values being present in the  
 vlv\_ott.dbs file. The length shall not exceed 8  
 characters

**REF\_SEC** Reference on the pipe cross-section for the second half of the valve

type: [TEXT](#)  
 unit: -  
 default value: current cross-section of the element  
 limitations: the cross-section shall be preliminarily described by  
 the [PIPE](#) command

**Note:**

- 1) See [Appendix IV](#).
- 2) *The internal nodes of the valve can be used only for referencing a support thereto. It cannot be used as a reference value (for example, in the [POS](#) command or in operations with copying the model segments)*

Example:

```
30: VA len = 400, dc = 0, 0, -600, xs = 'Pipe2', w = 2000,,, wop = 1000, dir = 0, 0
```

## Valve with offset (VO)

Valve between Nodes 1360 and 1370

Type: **With Offset** **VO**

Loads from DB: **OTT\_REF**

Label 1: 22

Label 2: 23

**OTT\_REF2**

Weights: **W(1)** **W(2)** **W(3)**

Body: 4500

Insulation: 61.705  Default

Medium: 0  Default

Actuator Weight: 1900 **WOP**

Nodes: Actuator's Restraining: **NODE** Support under Valve: **B\_NODE** 2940

Actuator's offset: **DIR(1-3)**

dX: 0 dY: 0 dZ: 1

Valve's offset: **OFF(1-3)**

dX: 0 dY: 0 dZ: 160 L1: 160

Coordinates  Cosines

L2: 0 L3: 969 L4: 0

Designation: 11JNG20AA001 **NOTE**

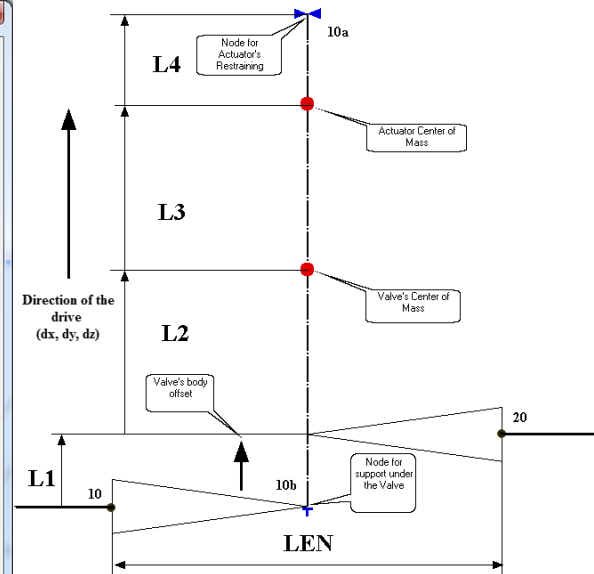

Valve with Offset model

Element's dialog allows to set points for the Valve's center of mass, center of mass of the actuator and the node, at which the drive restraining is possible ("Node for Actuator's restraining" field). It is supposed that these points lie on the same line, which direction is determined by means of direction cosines in the "Actuator's offset" field. The distance to these points is measured from the central point of the element according to the dimension chaining principle. Below the examples are given for determination of L1 - L4 parameters depending upon location of the points being determined.

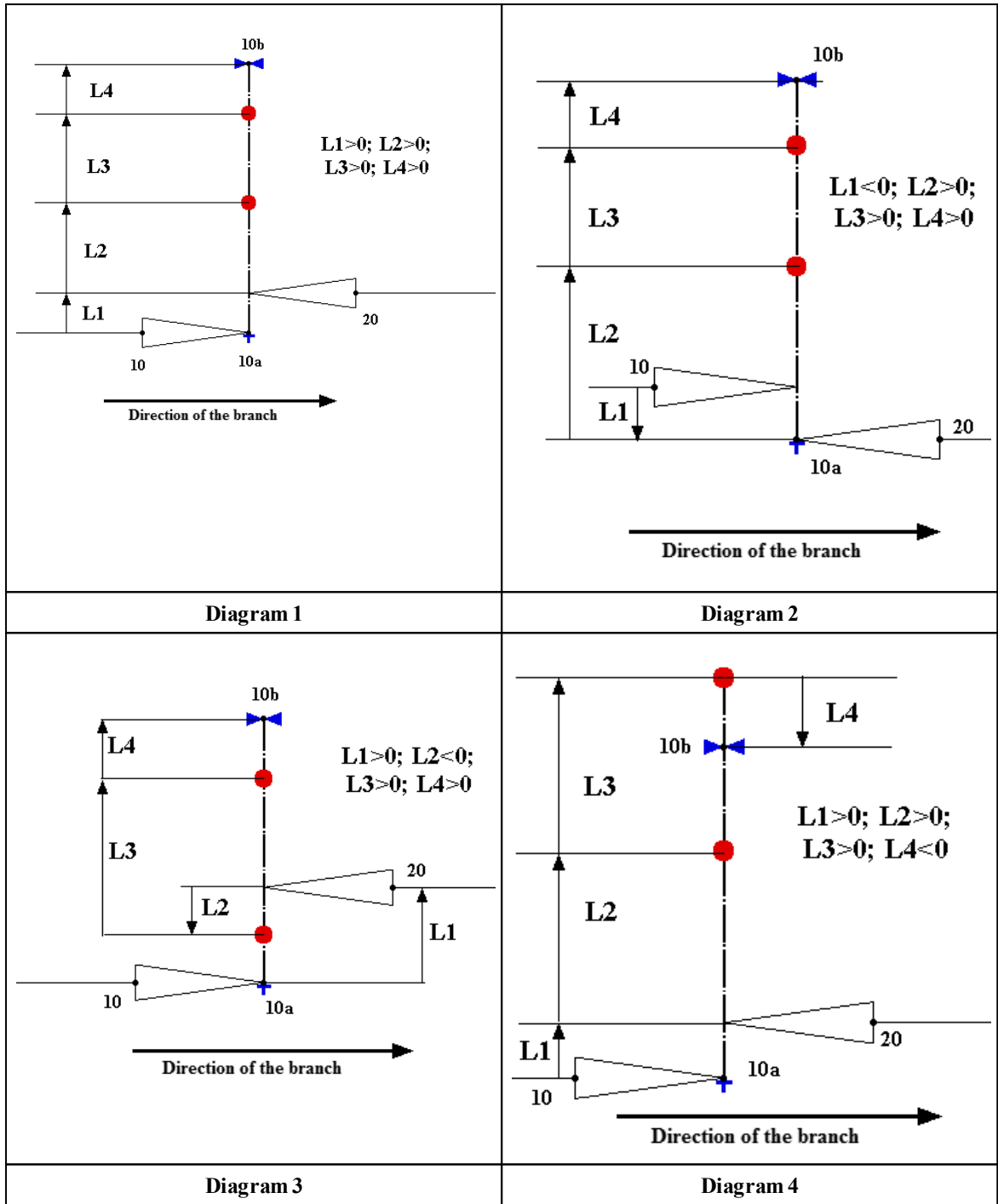

To set the supports in nodes 10a and 10b, it is necessary to call the "additional data" dialog (in the same line, in which the element is described) and transfer to the tab with the name of this node:

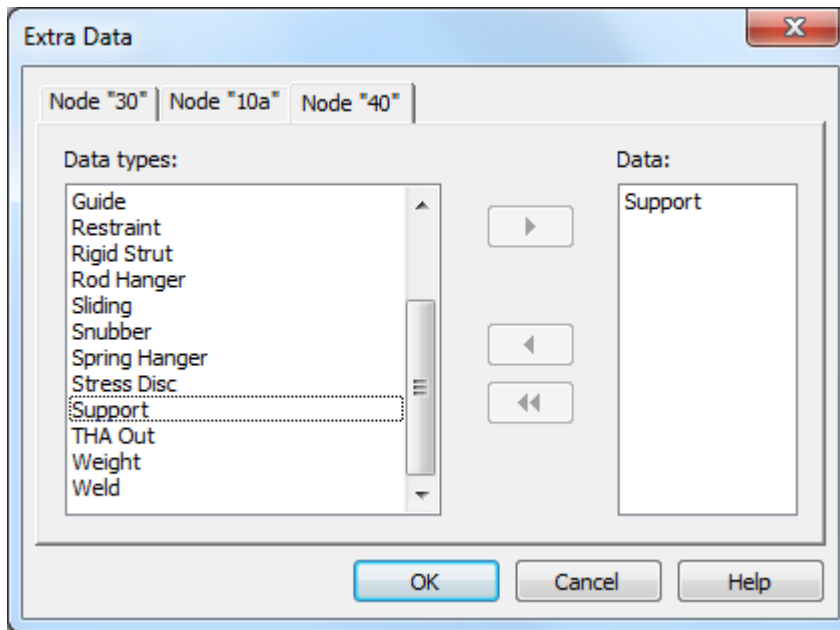

The input window provides separate setting of the valve weights: e.g. weight of the valve body and the weight of the actuator. With the flags marked by default, the weight of insulation and piping content will be added to the element depending upon the characteristics of the adjacent pipe and the current load group. In doing so, the weight of insulation is calculated with the coefficient 1.75 of the pipe's weight, and the weight of the piping content is added to be equal to the weight of the working fluid in the straight pipe. The user can redefine these parameters having removed the flag marks taken by default. If a positive number is entered, then it will be taken by the program as weight (of insulation or piping content) in Newtons. In case of negative values being entered the program will take them as multipliers to the weight of insulation or working fluid. If the dead weight is set equal to zero, then the weight of insulation and working fluid will not be added to the element by default.

The "Loads from DB" field serves for selecting permissible loads in accordance with NP-068-05 "Pipeline valves for nuclear plants. General technical requirements".

The "Designation" field is used for setting the identification name of valves. This information is output for printing in listings of the input data and the results of analysis.

**type:** local geometrical command

**Function:** determines the element for the simulation of valves and fittings (slides, gates, valves, etc.). The stiffness matrix for an element is formed the same as for the "straight pipe" element of the current cross-section with the wall thickness being multiplied by the [V\\_STF](#) factor.

**Parameters:**

**LEN** length of element (see analytical model of the valve)

type:	<a href="#">REAL</a>
unit:	mm
default value:	0
limitations:	$LEN \geq 0$

**DC or DS:** see ["Local commands" section](#) for the description of parameters.

**XS** change the cross-section type only for the current element without changing the current value for the rest of the segment

type:	<a href="#">TEXT</a>
unit:	-
default value:	mandatory parameter if the current cross-section is not initialized. Otherwise it takes the value of the current cross-section.
limitations:	the cross-section shall be preliminarily described by the <a href="#">PIPE</a> command

**LG** initialize the load group

type:	<a href="#">TEXT</a>
unit:	-
default value:	mandatory parameter if the load group is not initialized. Otherwise it takes the value of the current load group.
limitations:	the load group shall be preliminarily described by one of the "LG" subcommands of the <a href="#">OPVAL</a> command.

**W(3)** weight characteristics of the element<sup>1)</sup>

type:	<a href="#">REAL</a>
unit:	Newton
dimension	array of three numbers
default value:	see <a href="#">Appendix IV</a> .
limitations:	-

**MAT** - reference identification name of the material (see [MAT](#) command)

type:	<a href="#">TEXT</a>
unit:	-
default value:	-
limitations:	the name should coincide with the materials names determined earlier.

**WOP** weight of drive

type:	<a href="#">REAL</a>
unit:	Newton
default value:	0
limitations:	WOP ≥ 0

**DIR(3)** direction cosines for determination of the drive direction

type:	<a href="#">REAL</a>
unit:	mm
dimension	array of three numbers
default value:	0, 0, 0
limitations:	-

**OFF(3)** direction cosines or relative coordinates for determination of the housing displacement direction <sup>2)</sup>

type: [REAL](#)  
 unit: mm  
 dimension: array of three numbers  
 default value: 0, 0, 0  
 limitations: -

**LEN1, LEN2, LEN3, LEN4** distances determining the center of mass of the housing, center of mass of the drive and the drive detachment point (see Fig. with the analytical model).

type: [REAL](#)  
 unit: mm  
 default value: -  
 limitations: -

**NODE<sup>3)</sup>** name of the node for detachment of the drive

type: [TEXT](#)  
 unit: -  
 default value: -  
 limitations: see limitations for [node marks](#)

**B\_NODE<sup>3)</sup>** name of the node for the support under the valve housing

type: [TEXT](#)  
 unit: -  
 default value: -  
 limitations: see limitations for [node marks](#)

**NOTE** Note/Comment/- identification name of the valve

type: [STRING](#)  
 unit: -  
 default value: [blank](#)  
 limitations: see limitations for the string values of parameters, the length shall not be more than 32 characters

**NAME** - identification name of the piping segment

type: [STRING](#)  
 unit: -  
 default value: blank line or current identification name  
 limitations: see limitations for the string values of parameters, the length shall not be more than 32 characters

**OTT\_REF** label identifying a record in the database with permissible loads on the valve nozzle from the side of first element's node (see [Appendix X](#))

type: [TEXT](#)  
 unit: -  
 default value: -  
 limitations: to be determined by the values being present in the vlv\_ott.dbs file. The length shall not exceed 8 characters

**OTT\_REF1** label identifying a record in the database with permissible loads on the valve nozzle from the side of second element's node (see [Appendix X](#))

type: [TEXT](#)  
 unit: -  
 default value: -  
 limitations: to be determined by the values being present in the vlv\_ott.dbs file. The length shall not exceed 8 characters

**SBP** feature that defines the element and following portion of the piping as "small bore pipe" (initialization parameter), see [SBP](#)

**Note:**

- 1) See [Appendix IV](#).
- 2) If the *LEN1* parameter is set in the command, then the values of *OFF(1-3)* will be interpreted by the program as a set of direction cosines. Otherwise *OFF(1-3)* will be considered as relative coordinates.
- 3) The internal nodes of the valve can be used only for referencing a support thereto. They cannot be used as a reference value (for example, in the [POS](#) command or in operations with copying the model segments)

Example:

20: VO len = 130, w = 323,,, off = 0, 0, 1, len1 = 24, wop = 100, dir = 0, 0, 1, 1e

### 3-way valve (V3W)

3-Way Valve in Node 10

Loads from DB (body)  
Label: 123  
Select...

Loads from BD (branch)  
Label: 120  
Select...

Weights  
Body: 1000  
Insulation:  Default  
Medium:  Default

Actuator Weight: 2000  
Node for Actuator's Restraining:

Actuator's offset  
dX: 0    dY: 0    dZ: 1

L2: 0    L3: 300    L4: 0

VL1: 1000    VL2: 500  Default

Material: ST20    Show Scheme:

Designation: RA283S01

Comment: Check Weight !!!

Deactivate           

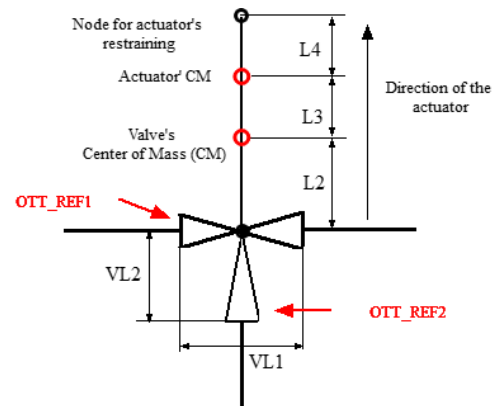

Three-way Valve model

The element "three-way valve" should be defined in the piping model in the same way as a TEE element through the entering in the "Add. Data" field:

The screenshot displays the dPIPE 5.27 software interface. The main window shows a 3D pipe model with nodes labeled 150, 170, 180, 190, 200, 210, 220, 230, 240, 250, 260, 270, 280, 290, 300, 310, 320, 330, 340, 350, 360, 370, 380, 390, 400, 410, 420, 430, 440, 450, 460, 470, 480, 490, 500, 510, 520, 530, 540, 550, 560, 570, 580, 590, 600, 610, 620, 630, 640, 650, 660, 670, 680, 690, 700, 710, 720, 730, 740, 750, 760, 770, 780, 790, 800, 810, 820, 830, 840, 850, 860, 870, 880, 890, 900, 910, 920, 930, 940, 950, 960, 970, 980, 990, 1000. Node 250 is highlighted with a red circle. The 'Extra Data' dialog box is open for Node 250, showing a list of data types and the selected '3-way Valve' in the 'Data' field. The 'Layout' table at the bottom shows the element data for Node 250, with a red arrow pointing to the 'Add. Data' column.

Node	Element	L/R	dX	dY	dZ	Add. Data	Section	Load
18	240		2000					
19	250		750				351x36aus	
20	260	From	6.12303E-017	0	-1	Anchor	351x36	LG1

In the dialog with the characteristics of the element, one can specify points for the center of mass of the valve body, the center of mass of the actuator and the node in which the actuator can be restrained (field "Node for actuator's restraining"). It is assumed that all these points lie on one straight line, the direction of which is determined by the direction cosines in the field "actuator's offset". The distance to the indicated points is measured from the central point of the element according to the principle a chain of dimensions. The following are examples of determining the parameters L2-L4 depending on the location of the points to be determined.

The support, for the actuator's restraining (if any), is entered in the same dialog "additional data" as the element itself on the tab with the name of this node:

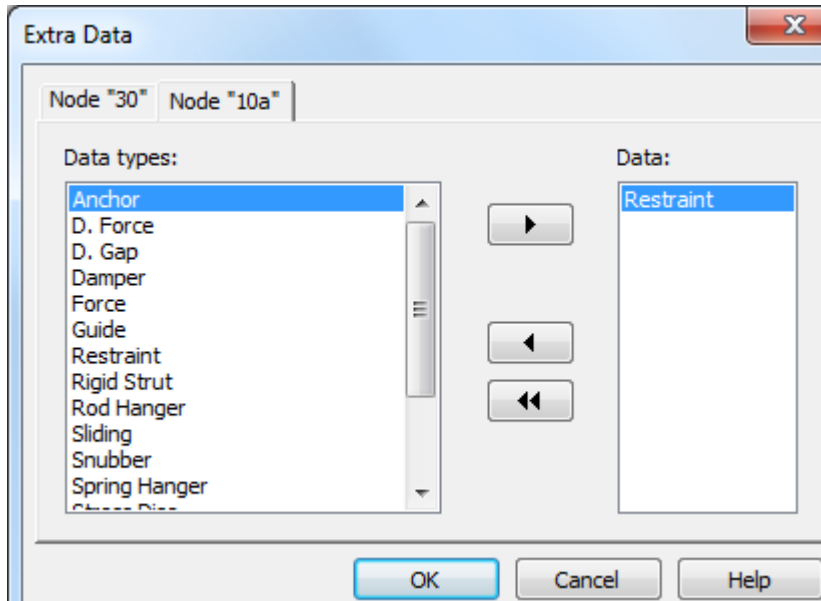

The input window provides separate setting of the valve weights: e.g. weight of the valve body and the weight of the actuator. With the flags marked by default, the weight of insulation and piping content will be added to the element depending upon the characteristics of the adjacent pipe and the current load group. In doing so, the weight of insulation is calculated with the coefficient 1.75 of the pipe's weight, and the weight of the piping content is added to be equal to the weight of the working fluid in the straight pipe. The user can redefine these parameters having removed the flag marks taken by default. If a positive number is entered, then it will be taken by the program as weight (of insulation or piping content) in Newtons. In case of negative values being entered the program will take them as multipliers to the weight of insulation or working fluid. If the dead weight is set equal to zero, then the weight of insulation and working fluid will not be added to the element by default.

The "Loads from DB" field serves for selecting permissible loads in accordance with NP-068-05 "Pipeline valves for nuclear plants. General technical requirements".

The "Designation" field is used for setting the identification name of valves. This information is output for printing in listings of the input data and the results of analysis.

**type:** local geometrical command

**Function:** determines the element for the simulation of valves and fittings (slides, gates, valves, etc.). The stiffness matrix for an element is formed the same as for the "straight pipe" element of the current cross-section with the wall thickness being multiplied by the [V\\_STF](#) factor.

**Parameters:**

**VL1** length of element (see model of the valve)

type:	<a href="#">REAL</a>
unit:	mm
default value:	0
limitations:	$VL1 > 0$

**VL2** length of the three-way valve's nozzle (see model of the valve)

type:	<a href="#">REAL</a>
unit:	mm
default value:	VL1/2
limitations:	VL2 > 0

**W(3)** weight characteristics of the element<sup>1)</sup>

type:	<a href="#">REAL</a>
unit:	Newton
dimension	array of three numbers
default value:	see <a href="#">Appendix IV</a> .
limitations:	-

**MAT** - reference identification name of the material (see [MAT](#) command)

type:	<a href="#">TEXT</a>
unit:	-
default value:	-
limitations:	the name should coincide with the materials names determined earlier.

**WOP** weight of drive

type:	<a href="#">REAL</a>
unit:	Newton
default value:	0
limitations:	WOP ≥ 0

**DIR(3)** direction cosines for determination of the drive direction

type:	<a href="#">REAL</a>
unit:	mm
dimension	array of three numbers
default value:	0, 0, 0
limitations:	-

**LEN2, LEN3, LEN4** distances determining the center of mass of the housing, center of mass of the drive and the drive detachment point (see Fig. with the model).

type:	<a href="#">REAL</a>
unit:	mm
default value:	-
limitations:	-

**NODE<sup>3)</sup>** name of the node for actuator's restraining

type:	<a href="#">TEXT</a>
unit:	-
default value:	-
limitations:	see limitations for <a href="#">node marks</a>

**NOTE** Note/Comment/- identification name of the valve

type: [STRING](#)  
unit: -  
default value: [blank](#)  
limitations: see limitations for the string values of parameters,  
the length shall not be more than 32 characters

**OTT\_REF1** label identifying a record in the database with permissible loads on the outlet valve's nozzles (see [Appendix X](#))

type: [TEXT](#)  
unit: -  
default value: -  
limitations: to be determined by the values being present in the  
vlv\_ott.dbs file. The length shall not exceed 8  
characters

**OTT\_REF2** label identifying a record in the database with permissible loads on the inlet valve's nozzle (see [Appendix X](#))

type: [TEXT](#)  
unit: -  
default value: -  
limitations: to be determined by the values being present in the  
vlv\_ott.dbs file. The length shall not exceed 8  
characters

**Note:**

- 1) See [Appendix IV](#).
- 2) *The internal nodes of the valve can be used only for referencing a support thereto. They cannot be used as a reference value (for example, in the [POS](#) command or in operations with copying the model segments)*

**Example:**

```
NODE: V3W v11 = 800, v12 = 300, w = 22000,,, note = "V1", ott_ref1 = '12', ott_ref2  
= '15'
```

## Expansion Joint (EJ)

Expansion joint between nodes "230" and "240"

Type: Non Standar

Aeff: PA, 68000

Exp: 0

Beta: 0

Stiffness

KA: 570  Default

KB1: 580000  Default

KS1: 5800  Default

KB2: 580000  Default

KS2: 5800  Default

KT: 1e+9  Default

Weights

Self Weight: 560  Default W(1)

Insulation: 360  Default W(2)

Medium: 2166.1  Default W(3)

Designation: AX1BU-16-300 NOTE

OK Cancel Help

**type:** local geometrical command

**Function:** command for modeling an expansion joint of the Custom (nonstandard) type

### Parameters:

**LEN** length of element

type:	<a href="#">REAL</a>
unit:	mm
default value:	0
limitations:	$LEN \geq 0$

**DC** or **DS:** see ["Local commands" section](#) for the description of parameters

**XS** change the cross-section type only for the current element without changing the current value for the rest of the segment

type:	<a href="#">TEXT</a>
unit:	-
default value:	the cross-section shall be preliminarily described by the PIPE command.
limitations:	the cross-section shall be preliminarily described by the <a href="#">PIPE</a> command

**LG** initialize the load group

type:	<a href="#">TEXT</a>
-------	----------------------

unit: -  
 default value: mandatory parameter if the load group is not initialized. Otherwise it takes the value of the current load group.  
 limitations: the load group shall be preliminarily described by one of the "LG" subcommands of the [OPVAL](#) command

**KA** axial spring rate (stiffness)

type: [REAL](#)  
 unit: N/mm  
 default value: axial stiffness of the matching pipe ( $E \cdot A / L$ )  
 limitations:  $\geq 0$

**KS(2)** lateral (shear) spring rate (1 - along the local Y axis of the element; 2 - along the local Z axis)

type: [REAL](#)  
 unit: N/mm  
 dimension: array of 2 elements  
 default value:  $\frac{12 \cdot E \cdot I}{L^3}$   
 $KS(1) = \frac{12 \cdot E \cdot I}{L^3}$  (shear stiffness of the matching pipe);  
 $KS(2) = KS(1)$   
 limitations:  $\geq 0$

**KB(2)** bending spring rate(1 - with respect to the local Y axis of the element; 2 - with respect to the local Z axis)

type: [REAL](#)  
 unit: N\*mm/rad  
 dimension: array of 2 elements  
 default value:  $\frac{E \cdot I}{L}$   
 $KB(1) = \frac{E \cdot I}{L}$  (bending stiffness of the matching pipe);  
 $KB(2) = KB(1)$   
 limitations:  $\geq 0$

**KT** torsional spring rate

type: [REAL](#)  
 unit: N\*mm/rad  
 default value: torsional stiffness of the matching pipe:  
 $\frac{E \cdot I}{L \cdot (1 + \mu)}$   
 limitations:  $\geq 0$

**PA** effective area of the expansion joint

type: [REAL](#)  
 unit:  $mm^2$   
 default value: 0  
 limitations:  $\geq 0$

**W(3)** weight of the expansion joint<sup>1)</sup>

type:	<a href="#">REAL</a>
unit:	Newton
dimension	array of three numbers
default value:	see <a href="#">Appendix IV</a> .
limitations:	-

**EXP** thermal expansion multiplier<sup>3)</sup>

type:	<a href="#">REAL</a>
unit:	-
default value:	0
limitations:	$\geq 0$

**BETA** angle to set orientation of element with respect to its axis (see [Example of setting](#))

type:	<a href="#">REAL</a>
unit:	degrees
default value:	0
limitations:	$ \text{BETA}  \leq 360$

**NAME** - identification name of the piping segment

type:	<a href="#">STRING</a>
unit:	-
default value:	blank line or current identification name .
limitations:	see limitations for the string values of parameters, the length shall not be more than 32 characters

**SBP** feature that defines the element and following portion of the piping as "small bore pipe" (initialization parameter), see [SBP](#)

**NOTE** Element ID

type:	<a href="#">STRING</a>
unit:	-
default value:	<a href="#">blank</a>
limitations:	see limitations for the string values of parameters, the length shall not be more than 32 characters

**Note:**

- 1) When  $PA > 0$  the longitudinal load (pressure thrust)  $R = PA \cdot P(op)$  will be applied at the ends of the element ( $P(op)$  is the internal pressure concurrent with operation mode)
- 2) Thermal expansion multiplier  $EXP$  is used to scale current thermal expansion factor of the pipe adjacent to the bellow to the expansion joint material property:  $TEXP (EXPJ) = EXP \cdot TEXP (pipe)$
- 3) The lateral stiffness  $KS$  of the expansion joint corresponds to the parallel-plane deformation pattern for the ends of the element. The bending stiffness  $KB$  of the expansion joint

corresponds to the deformation of a cantilevered beam under the action of concentrated moment:

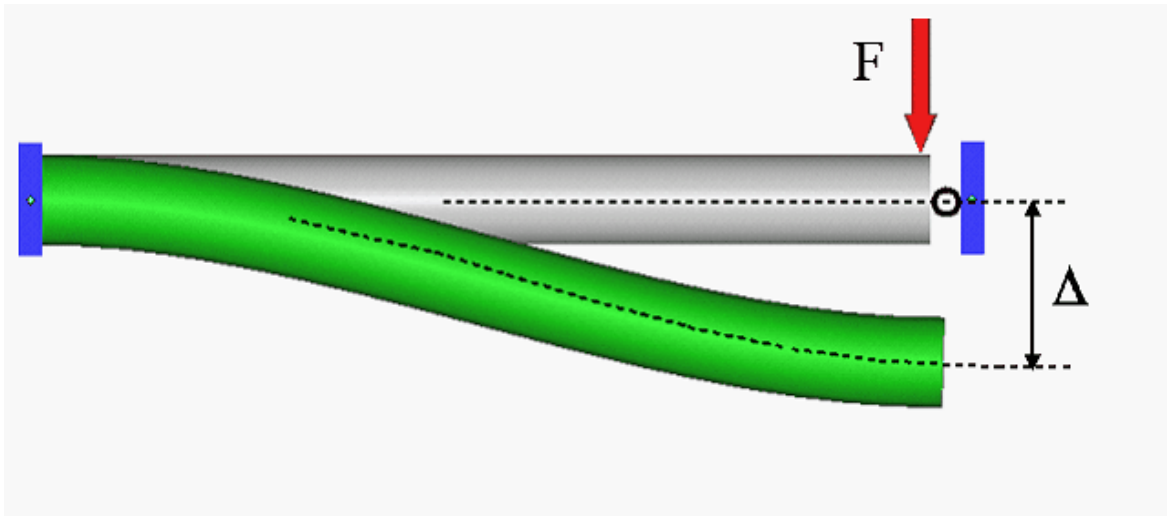

Expansion joint lateral movement pattern ( $F = KS \cdot \Delta$ )

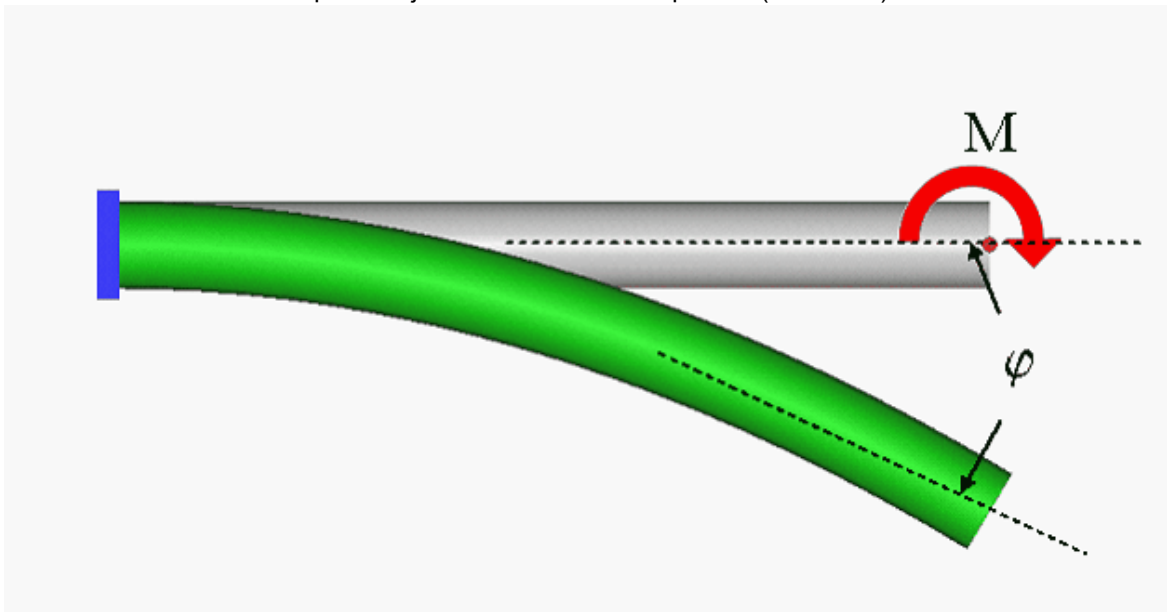

Expansion joint bending deflection pattern ( $M = KB \cdot \varphi$ )

4) To get results of analysis for expansion joints (transverse and angular deformations) it's necessary to set the output of internal forces in the [POST](#) command for the load combination being of interest ( $RES = 'FORC'$  parameter). In doing so, a separate table containing deformations (linear and angular) will be printed out in the <model name>.sup file for each expansion joint for all sets of results with internal forces.

Example:

```
2000: EJ 1000 KA 100. KS 150 200. KB 320 340 KT 1000 PA 203 W 80, -1.2, -1
```

All expansion joint subtypes: [Axial \(EA\)](#), [Tied \(ET\)](#), [Hinge \(EH\)](#), [Gimbal \(EG\)](#) are modeled with use the following values of its parameters:

Modeling of Expansion Joints

TYPE	KA	KS(1)	KS(2)	KB(1)	KB(2)	KT	PA	EXP
------	----	-------	-------	-------	-------	----	----	-----

<b>EA</b>	ka	ks	ks	kb	kb	R	pa	1
ET (>2 tie rods)	R	ks	ks	R	R	R	0	0
ET (2 tie rods)	R	ks	ks	kb	R	R	0	0
<b>EH</b>	R	R	R	kb	R	R	0	0
<b>EG</b>	R	R	R	kb	kb	R	0	0

**Note:** R - "rigid" value, corresponds to relevant stiffness of the matched pipe:

Stiffness	Formula
Axial (KA)	$\frac{E * A}{L}$
Shear (KS)	$\frac{E * I}{L^3}$
Bending (KB)	$\frac{E * I}{L}$
Torsion (KT)	$\frac{E * I}{L * (1 + \mu)}$

### Axial Expansion Joint (EA)

Expansion joint between nodes "230" and "240" ✕

Type: Axial      Aeff: **PA**      Exp: 1      Beta: 0

**Stiffness**

KA: 570  Default      KB1: 580000  Default

KS1: 5800  Default      KB2: 580000  Default

KS2: 5800  Default      KT: 1e+009  Default

**Weights**

Self Weight: 560  Default **W(1)**

Insulation: 360  Default **W(2)**

Medium: 2166.1  Default **W(3)**

Designation **NOTE**

AXIBU-16-300

OK
Cancel
Help

**type:** local geometrical command

**Function:** command for modeling an axial expansion joint

**Parameters:**

**LEN** length of element

type:	<a href="#">REAL</a>
unit:	mm
default value:	0
limitations:	$LEN \geq 0$

**DC** or **DS**: see ["Local commands" section](#) for the description of parameters

**XS** change the cross-section type only for the current element without changing the current value for the rest of the segment

type:	<a href="#">TEXT</a>
unit:	-
default value:	the cross-section shall be preliminarily described by the <a href="#">PIPE</a> command.
limitations:	the cross-section shall be preliminarily described by the <a href="#">PIPE</a> command

**LG** initialize the load group

type:	<a href="#">TEXT</a>
unit:	-
default value:	mandatory parameter if the load group is not initialized. Otherwise it takes the value of the current load group.
limitations:	the load group shall be preliminarily described by one of the "LG" subcommands of the <a href="#">OPVAL</a> command

**KA** axial spring rate (stiffness)

type:	<a href="#">REAL</a>
unit:	N/mm
default value:	-
limitations:	$\geq 0$

**KS** lateral (shear) spring rate

type:	<a href="#">REAL</a>
unit:	N/mm
default value:	-
limitations:	$\geq 0$

**KB** bending spring rate

type:	<a href="#">REAL</a>
unit:	N*mm/rad
default value:	-
limitations:	$\geq 0$

**KT** torsional spring rate

type:	<a href="#">REAL</a>
unit:	N*mm/rad

default value:  $\frac{E * I}{L * (1 + \mu)}$   
 limitations: torsional stiffness of the matching pipe:  $\geq 0$

**PA** effective area of the expansion joint

type: [REAL](#)  
 unit: mm<sup>2</sup>  
 default value: -  
 limitations:  $\geq 0$

**W(3)** weight of the expansion joint<sup>1)</sup>

type: [REAL](#)  
 unit: Newton  
 dimension: array of three numbers  
 default value: see [Appendix IV](#).  
 limitations: -

**NAME** - identification name of the piping segment

type: [STRING](#)  
 unit: -  
 default value: blank line or current identification name .  
 limitations: see limitations for the string values of parameters, the length shall not be more than 32 characters

**SBP** feature that defines the element and following portion of the piping as "small bore pipe" (initialization parameter), see [SBP](#)

**NOTE** Element ID

type: [STRING](#)  
 unit: -  
 default value: [blank](#)  
 limitations: see limitations for the string values of parameters, the length shall not be more than 32 characters

**Note:**

- 1) *Mandatory parameter to be used for computation of the pressure thrust consistent with operating modes.*
- 2) *See [Appendix IV](#).*

Example :

A10: EA 340, ka = 61.294, ks = 252.358, kb = 1.84E+006, pa = 1.88E5, w = 747.3

See also: [Modeling of Expansion Joints](#)

## Tied Expansion Joint (ET)

Expansion Joint between Nodes "170" and "180".

Type: Tied

Aeff: 0

Exp: 0

Beta: 0

Stiffness

KA: rigid  Default

KB1: 76800  Default

KS1: 5800  Default

KB2: rigid  Default

KS2: 5800  Default

KT: rigid  Default

Weights

Self Weight: 560  Default **W(1)**

Insulation: 280  Default **W(2)**

Medium: 275.431  Default **W(3)**

Designation: AX 1BU-16-300

Note

OK Cancel Help

**type:** local geometrical command

**Function:** command for modeling a tied Expansion Joint

### Parameters:

**LEN** length of element

type: [REAL](#)  
 unit: mm  
 default value: 0  
 limitations:  $LEN \geq 0$

**DC** or **DS:** see ["Local commands" section](#) for the description of parameters

**XS** change the cross-section type only for the current element without changing the current value for the rest of the segment

type: [TEXT](#)  
 unit: -  
 default value: the cross-section shall be preliminarily described by the PIPE command.  
 limitations: the cross-section shall be preliminarily described by the [PIPE](#) command

**LG** initialize the load group

type: [TEXT](#)  
 unit: -  
 default value: mandatory parameter if the load group is not initialized. Otherwise it takes the value of the current load group.  
 limitations: the load group shall be preliminarily described by one of the "LG" subcommands of the [OPVAL](#) command

**KS** lateral (shear) spring rate

type: [REAL](#)  
 unit: N/mm  
 default value: -  
 limitations:  $\geq 0$

**KB<sup>1)</sup>** bending spring rate

type: [REAL](#)  
 unit: N\*mm/rad  
 default value: -  
 limitations:  $\geq 0$

**BETA<sup>1)</sup>** angle to set orientation of element with respect to its axis (see [Example of setting](#))

type: [REAL](#)  
 unit: degrees  
 default value: 0  
 limitations:  $|\text{BETA}| \leq 360$

**W(3)** weight of the expansion joint<sup>2)</sup>

type: [REAL](#)  
 unit: Newton  
 dimension: array of three numbers  
 default value: see [Appendix IV](#).  
 limitations: -

**NAME** - identification name of the piping segment

type: [STRING](#)  
 unit: -  
 default value: blank line or current identification name .  
 limitations: see limitations for the string values of parameters, the length shall not be more than 32 characters

**SBP** feature that defines the element and following portion of the piping as "small bore pipe" (initialization parameter), see [SBP](#)

**NOTE** Element ID

type: [STRING](#)

unit: -  
 default value: [blank](#)  
 limitations: see limitations for the string values of parameters,  
 the length shall not be more than 32 characters

**Note:**

1. **For modeling the expansion joint having 2 tie rods the setting of KB and BETA parameters is mandatory.** In case of the angle  $BETA = 0$ , it is assumed that the tie rods are located in the local X-Y plane of the element.
2. See [Appendix IV](#).

Example:

```
2000: ET 1000 KS 100. KB 1000. BETA 30
```

See also: [Modeling of Expansion Joints](#)

**Hinge Expansion Joint (EH)**

Expansion joint between nodes "230" and "240"

Type: **Hinged**      Aeff: 0      Exp: 0      Beta: 0

**Stiffness**

KA: 1e+009  Default      KB1: 580000  Default

KS1: 1e+009  Default      KB2: 1e+014  Default

KS2: 1e+009  Default      KT: 1e+014  Default

**Weights**

Self Weight: 560  Default **W(1)**

Insulation: 360  Default **W(2)**

Medium: 2166.1  Default **W(3)**

Designation **NOTE**

AX1BU-16-300

OK      Cancel      Help

**type:** local geometrical command

**Function:** command for modeling a hinge expansion joint<sup>1)</sup>

**Parameters:**

**LEN**      length of element

type: [REAL](#)

unit: mm  
 default value: 0  
 limitations:  $LEN \geq 0$

**DC** or **DS**: see ["Local commands" section](#) for the description of parameters

**XS** change the cross-section type only for the current element without changing the current value for the rest of the segment

type: [TEXT](#)  
 unit: -  
 default value: the cross-section shall be preliminarily described by the PIPE command.  
 limitations: the cross-section shall be preliminarily described by the [PIPE](#) command

**LG** initialize the load group

type: [TEXT](#)  
 unit: -  
 default value: mandatory parameter if the load group is not initialized. Otherwise it takes the value of the current load group.  
 limitations: the load group shall be preliminarily described by one of the "LG" subcommands of the [OPVAL](#) command

**KB** bending spring rate

type: [REAL](#)  
 unit: N\*mm/rad  
 default value: -  
 limitations:  $\geq 0$

**BETA**<sup>1)</sup> angle to set orientation of element with respect to its axis (see [Example of setting](#))

type: [REAL](#)  
 unit: degrees  
 default value: 0  
 limitations:  $|BETA| \leq 360$

**W(3)** weight of the expansion joint<sup>2)</sup>

type: [REAL](#)  
 unit: Newton  
 dimension: array of three numbers  
 default value: see [Appendix IV](#).  
 limitations: -

**NAME** identification name of the piping segment

type: [STRING](#)  
 unit: -

default value: blank line or current identification name .  
 limitations: see limitations for the string values of parameters, the length shall not be more than 32 characters

**SBP** feature that defines the element and following portion of the piping as "small bore pipe" (initialization parameter), see [SBP](#)

**NOTE**

Element ID

type: [STRING](#)

unit: -

default value: [blank](#)

limitations: see limitations for the string values of parameters, the length shall not be more than 32 characters

**Note:**

- 1) In case if the angle  $BETA = 0$ , it is assumed that the hinge expansion joint allows rotating about the local Y axis of the element;
- 2) See [Appendix IV](#) .

Example:

2000: EH 1000 KB 1000. BETA 30

See also: [Modeling of Expansion Joints](#)**Gimbal Expansion Joint (EG)**

Expansion joint between nodes "230" and "240"

Type	Aeff	Exp	Beta
Gimbal	0	0	0

Stiffness		Weights	
KA	KB1	Self Weight	
1e+009 <input checked="" type="checkbox"/> Default	580000 <input type="checkbox"/> Default	560 <input type="checkbox"/> Default	<b>W(1)</b>
KS1	KB2	Insulation	
1e+009 <input checked="" type="checkbox"/> Default	1e+014 <input checked="" type="checkbox"/> Default	360 <input checked="" type="checkbox"/> Default	<b>W(2)</b>
KS2	KT	Medium	
1e+009 <input checked="" type="checkbox"/> Default	1e+014 <input checked="" type="checkbox"/> Default	2166.1 <input checked="" type="checkbox"/> Default	<b>W(3)</b>

Designation **NOTE**

AX1BU-16-300

OK Cancel Help

**type:** local geometrical command

**Function:** command for modeling a gimbal expansion joint

**Parameters:**

**LEN** length of element

type: [REAL](#)  
 unit: mm  
 default value: 0  
 limitations:  $LEN \geq 0$

**DC** or **DS:** see ["Local commands" section](#) for the description of parameters

**XS** change the cross-section type only for the current element without changing the current value for the rest of the segment

type: [TEXT](#)  
 unit: -  
 default value: the cross-section shall be preliminarily described by the PIPE command.  
 limitations: the cross-section shall be preliminarily described by the [PIPE](#) command

**LG** initialize the load group

type: [TEXT](#)  
 unit: -  
 default value: mandatory parameter if the load group is not initialized. Otherwise it takes the value of the current load group.  
 limitations: the load group shall be preliminarily described by one of the "LG" subcommands of the [OPVAL](#) command

**KB** bending spring rate

type: [REAL](#)  
 unit: N\*mm/rad  
 default value: -  
 limitations:  $\geq 0$

**W(3)** weight of the expansion joint<sup>2)</sup>

type: [REAL](#)  
 unit: Newton  
 dimension: array of three numbers  
 default value: see [Appendix IV](#).  
 limitations: -

**NAME** identification name of the piping segment

type: [STRING](#)  
 unit: -

default value: blank line or current identification name .  
 limitations: see limitations for the string values of parameters, the length shall not be more than 32 characters

**SBP** feature that defines the element and following portion of the piping as "small bore pipe" (initialization parameter), see [SBP](#)

**NOTE**

Element ID

type: [STRING](#)

unit: -

default value: [blank](#)

limitations: see limitations for the string values of parameters, the length shall not be more than 32 characters

**Note:**1) See [Appendix IV](#).

Example:

2000: EG 1000 KB 1000.

See also: [Modeling of Expansion Joints](#)**Rigid Link (RX/RP)**

**type:** local geometrical command

**Function:** command for modeling a "rigid" element. Depending upon the type of displaying, the following is used: RX - rigid link and RP - "thick" pipe.

**Parameters:****LEN** length of element

type:	<a href="#">REAL</a>
unit:	mm
default value:	0
limitations:	LEN ≥ 0

**DC** or **DS**: see ["Local commands" section](#) for the description of parameters**XS** change the cross-section type only for the current element without changing the current value for the rest of the segment

type:	<a href="#">TEXT</a>
unit:	-
default value:	the cross-section shall be preliminarily described by the PIPE command.
limitations:	the cross-section shall be preliminarily described by the <a href="#">PIPE</a> command

**LG** initialize the load group

type:	<a href="#">TEXT</a>
unit:	-
default value:	mandatory parameter if the load group is not initialized. Otherwise it takes the value of the current load group.
limitations:	the load group shall be preliminarily described by one of the "LG" subcommands of the <a href="#">OPVAL</a> command

**W(3)** weight of the element<sup>2)</sup>

type:	<a href="#">REAL</a>
unit:	Newton
dimension	array of three numbers
default value:	see <a href="#">Appendix IV</a> .
limitations:	-

**SFAC** scaling factor at the pipe wall thickness<sup>1)</sup>

type:	<a href="#">REAL</a>
unit:	-
default value:	10
limitations:	> 0

**NAME** - identification name of the piping segment

type:	<a href="#">STRING</a>
unit:	-
default value:	blank line or current identification name .
limitations:	see limitations for the string values of parameters, the length shall not be more than 32 characters

**SBP** feature that defines the element and following portion of the piping as "small bore pipe" (initialization parameter), see [SBP](#)

**Note:**

- 1) The element is simulated using a pipe with the current internal diameter and the wall thickness increased by SFAC times:  $T = T * SFAC$
- 2) See [Appendix IV](#).

Example:

```
2000: RX 1000 SFAC .5
```

### Flexible Joint (FJ)

**type:** local geometrical command

**Function:** command for modeling a flexible joint

**Parameters:**

**DC** or **DS:** see ["Local commands" section](#) for the description of parameters

**KA** axial spring rate (stiffness)

type: [REAL](#)  
 unit: N/mm  
 default value: [rigid](#)  
 limitations:  $\geq 0$

**KS(2)** lateral (shear) spring rate

type: [REAL](#)  
 unit: N/mm  
 dimension: array of two numbers

	default value:	KS(1) = <a href="#">rigid</a> , KS(2) = KS(1)
	limitations:	$\geq 0$
<b>KB(2)</b>	bending spring rate	
	type:	<a href="#">REAL</a>
	unit:	N*mm/rad
	dimension	array of two numbers
	default value:	KB(1) = <a href="#">rigid</a> , KB(2) = KB(1)
	limitations:	$\geq 0$
<b>KT</b>	torsional spring rate of the joint	
	type:	<a href="#">REAL</a>
	unit:	N*mm/rad
	default value:	<a href="#">rigid</a>
	limitations:	$\geq 0$
<b>BETA</b>	angle to set orientation of element with respect to its axis (see <a href="#">Example of setting</a> )	
	type:	<a href="#">REAL</a>
	unit:	degrees
	default value:	0
	limitations:	$ \text{BETA}  \leq 360$
<b>NAME</b>	identification name of the piping segment	
	type:	<a href="#">STRING</a>
	unit:	-
	default value:	blank line or current identification name .
	limitations:	see limitations for the string values of parameters, the length shall not be more than 32 characters
<b>NOTE</b>	Element ID	
	type:	<a href="#">STRING</a>
	unit:	-
	default value:	<a href="#">blank</a>
	limitations:	see limitations for the string values of parameters, the length shall not be more than 32 characters

**SBP** feature that defines the element and following portion of the piping as "small bore pipe" (initialization parameter), see [SBP](#)

**Note:**

*The flexible joint has the zero length. It is used for setting the local flexibility (stiffness) in the model. The values KA and KT shall be set with respect to the local "A" axis, KS(1) and KB(1) - with respect to the local "H" axis, KS(2) and KB(2) - with respect to the local "N" axis (see [Example of setting](#));*

Example :

2000: FJ KA 1.e2 KB 3.e4 KS 1.e4 2.1e4 KT 1.e4 beta 45 dc 0 1 1

## Cold Spring (CS)

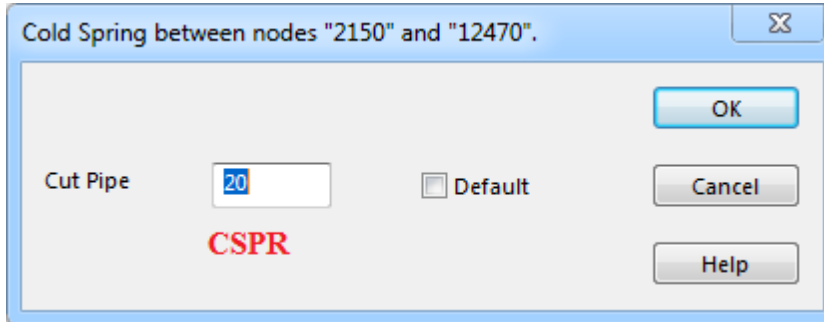

**type:** local geometrical command

**Function:** element for modeling a cold spring

**Parameters:**

**LEN**<sup>1)</sup> length of element

type:	<a href="#">REAL</a>
unit:	mm
default value:	0
limitations:	$\geq 0$

**DC** or **DS:** see ["Local commands" section](#) for the description of parameters

**XS** change the cross-section type only for the current element without changing the current value for the rest of the segment

type:	<a href="#">TEXT</a>
unit:	-
limitations:	the cross-section shall be preliminarily described by the <a href="#">PIPE</a> command

**CSPR** cold spring value

type:	<a href="#">REAL</a>
unit:	mm
default value:	LEN
limitations:	-

**NAME** - identification name of the piping segment

type:	<a href="#">STRING</a>
unit:	-
default value:	blank line or current identification name .

limitations: see limitations for the string values of parameters, the length shall not be more than 32 characters

**Note:**

- 1) *The element length can be equal to zero.*
- 2) *To set Cold Spring in force a corresponding option 'CS' should be used within SOLV command. See [Appendix VII](#) for comments to the specification for analysis of the piping system with the cold spring*

Example :

```
10: CS 145 dc 1,0,0 xs 'CS250A' CSPR = 100.
```

## Beam (S)

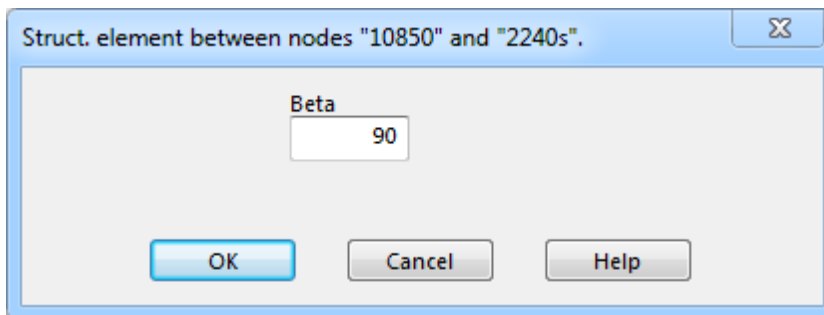

**type:** local geometrical command

**Function:** command for modeling a beam elements (structural elements)

**Parameters:**

**LEN** length of element

type:	<a href="#">REAL</a>
unit:	mm
default value:	0
limitations:	LEN ≥ 0

**DC** or **DS**: see ["Local commands" section](#) for the description of parameters

**BEAM** - identification name of the cross-section

type:	<a href="#">TEXT</a>
unit:	-
default value:	-
limitations:	the cross-section shall be preliminarily described by the <a href="#">BEAM</a> command

**BETA**<sup>1)</sup> angle to set orientation of element with respect to its axis

type: [REAL](#)  
unit: degrees  
default value: 0  
limitations:  $|\text{BETA}| \leq 360$

**NAME** - identification name of the piping segment

type: [STRING](#)  
unit: -  
default value: blank line or current identification name .  
limitations: see limitations for the string values of parameters, the length shall not be more than 32 characters

**SBP** feature that defines the element and following portion of the piping as "small bore pipe" (initialization parameter), see [SBP](#)

Notes:

- 1) The angle BETA defines the rotation of cross-section around the local A axis. An example of setting the BETA angle and the positive direction of its counting are shown in the following figure:

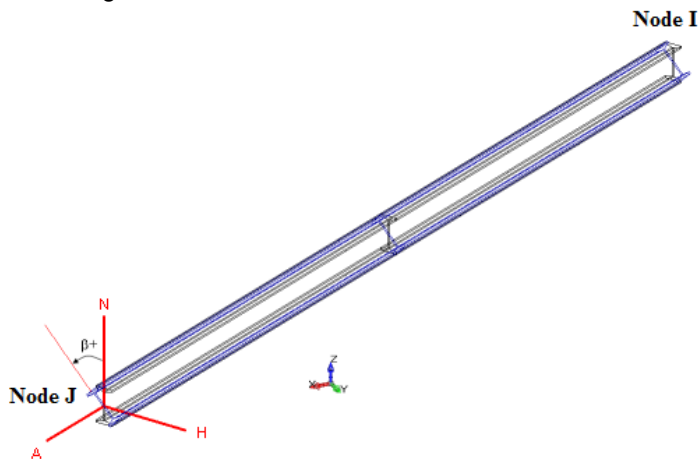

- 1) the local A axis is not parallel to the global Z axis.

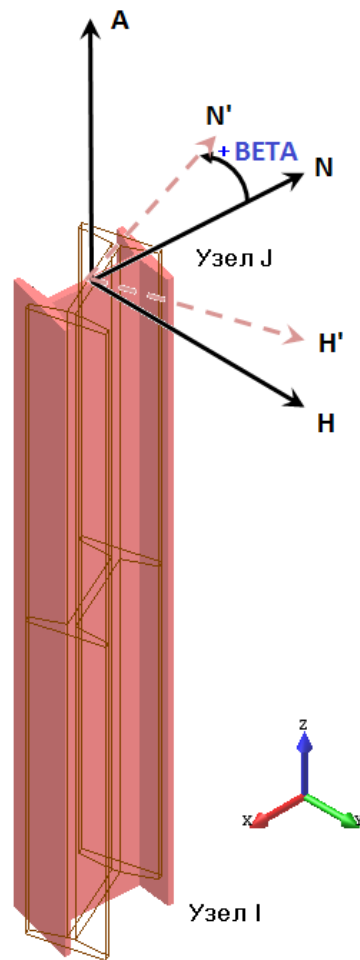

2) the local A axis is parallel to the global Z axis (H is directed along the global Y axis).

Example:

```
2000: S LEN 1000 BEAM 'L10'
```

### Set Position (POS)

**type:** local geometrical command

**Function:** command for setting the global or relative coordinates of the node. If model does not contain the POS command, then the global coordinates of the first node of the model are set to zero. When POS is assigned to some node, the global coordinates of the model are recalculated. Existing of two or more POS commands could lead to the conflict between model's global coordinates. In such a case a warning message will appear.

**Parameters:**

**X, Y, Z** global coordinate of the node

type: [REAL](#)  
 unit: mm  
 default value: -  
 limitations: -

**NODE** label of the node to be linked

type: [TEXT](#)  
 unit: -  
 default value: -  
 limitations: the parameter shall refer to the label of one of the existing nodes of the model

*Note:*

To set POS command the following actions should be executed:

1. Place the mouse cursor to the required node and select the "Properties" item:

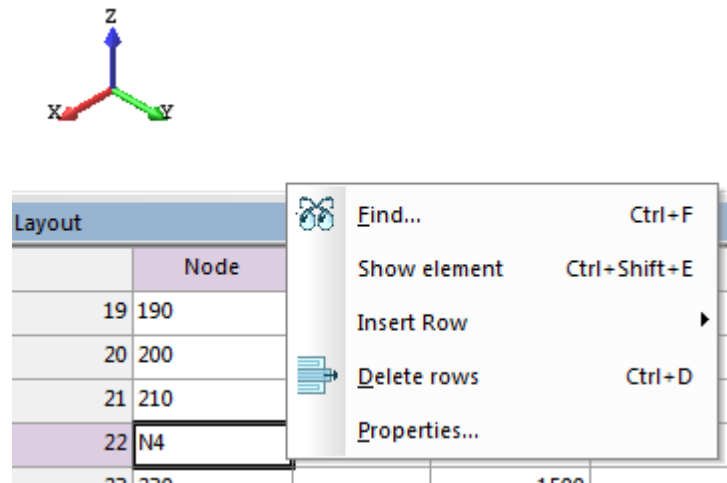

2. Click the "Properties" item in the dialog appeared and enter either the absolute global coordinates of the node or define them with respect to the coordinates of the existing node:

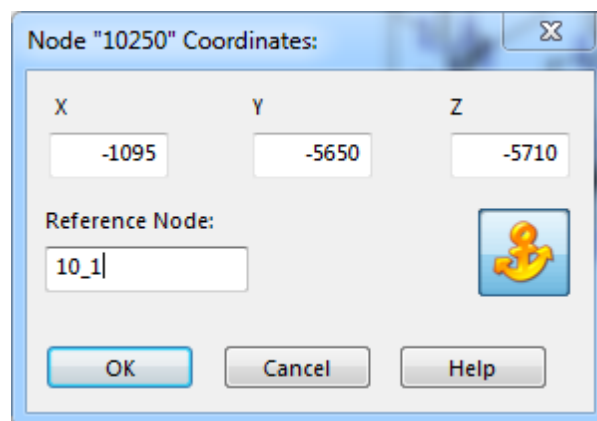

3. Press "OK". In doing so the node, for which the absolute global coordinates are set, will be marked with the blue-colored "anchor" symbol:

Layout			
	Node	Element	L/R
16	130		1000
17	140		1285
18	150		1285
	19 160		1285
	20 170		1285
	21 180	Bend	600

Ready

if the coordinates are set with respect to the existing node, then the anchor will be displayed in green:

	13 190	
	14 200	From
	15 210	

If there are geometric links between various nodes in the model, they can be displayed by means of the "[Display parameters](#)" menu ("Geometric links" option):

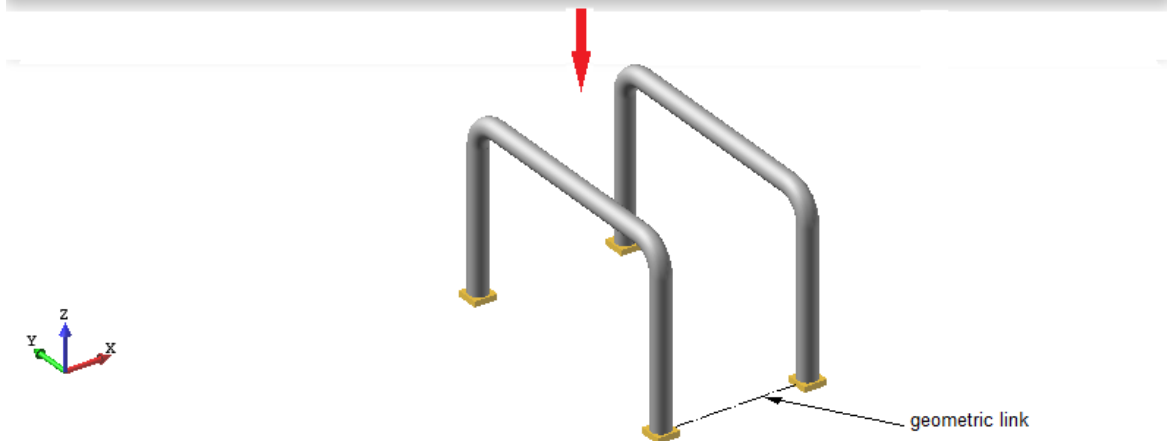
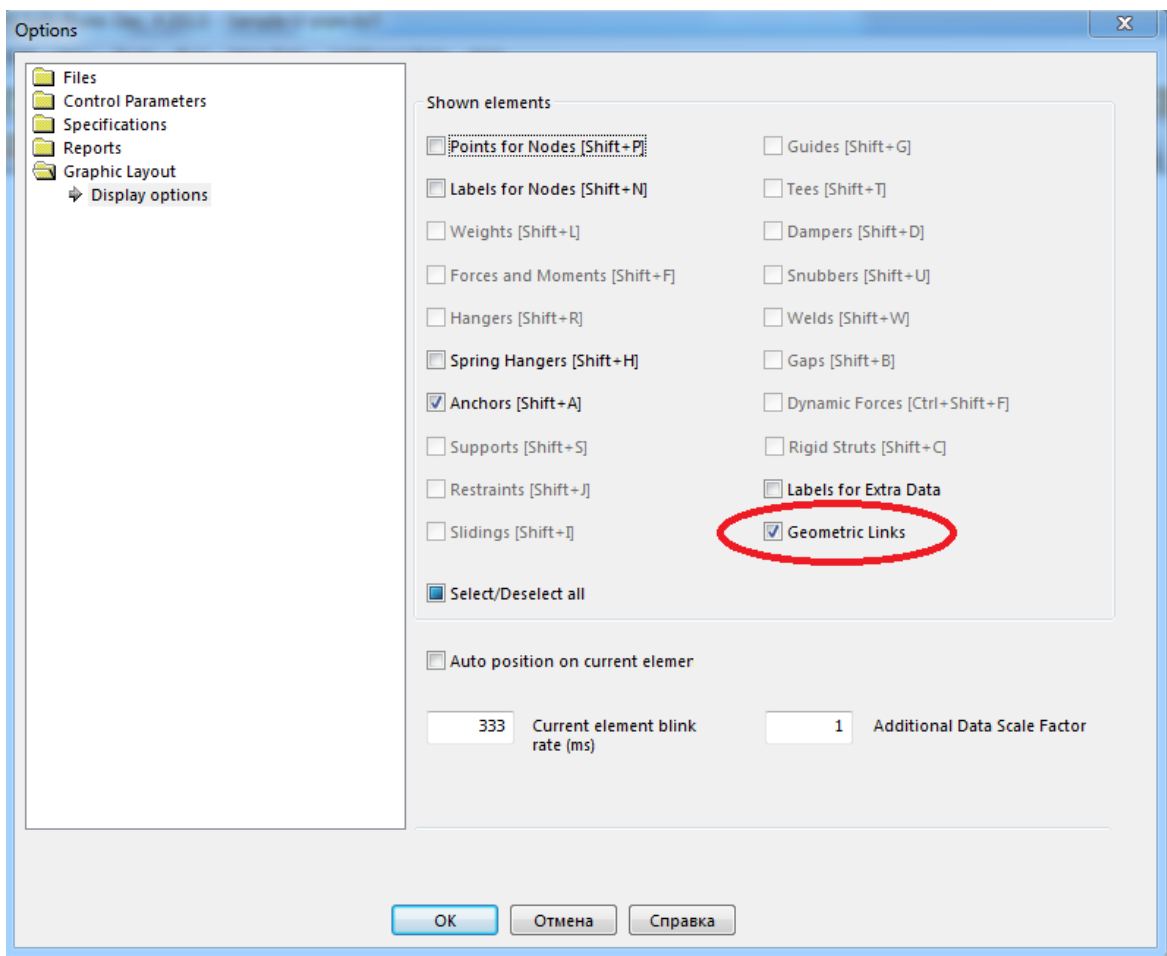

Example:

```
20: POS 0, -2000, 0 NODE '10A'
```

### Tee/Branch Connection (TEE)

**1) Starting from dPIPE 5.27, this command is not recommended for the input of tees. Instead, use the command for the "standard" tees**

**2) The command is not compatible with the calculations according to the EN Norms of the 2020 edition**

The screenshot shows the 'Tee' dialog box with the following details:

- Node:** 270
- Branch Parameters:**
  - Diameter (DB): 273
  - Wall Thickness (TB): 8
  - Corrosion Allowances: 1.7
  - Label: **CB**
- Run Parameters:**
  - Diameter (DR): 377
  - Wall Thickness (TR): 9
  - Corrosion Allowances: 1.85
  - Label: **CR**
- Default:**  Default
- Designation:** NOTE  Deactivate
- Buttons:** RD Code, OK, Cancel, Help

**type:** local geometrical command

**Function:** Command for setting the characteristics of tees/branch connections located in the current node. Command is available only if node belongs to several interconnected elements that form branching. Dialog and list of parameters are dependent on the Stress Code used.

**Parameters:**

**TYPE** type of the tee

type: [TEXT](#)  
 unit: mm  
 default value: 'WLD'  
 limitations: in accordance with the codes, see the following table:

<a href="#">CODE</a>	<a href="#">CODE_YEAR</a>	TYPE	Description in accordance with the Codes
ASME_B311	2008	WLD	Welding tee per ASME B16.9
		RF_TEE	Reinforced fabricated tee
		URF_TEE	Unreinforced fabricated tee

		RF_BRC	Branch welded-on fitting (integrally reinforced) per MSS SP-97
		EX_OUT	Extruded outlet meeting the requirements of para. 104.3.1(G)
		WLD_INS	Welded-in contour insert
		BRC	Branch connection
ASME_NC	1992	WLD	Welding Tee per ANSI B19.6 (1)
		BRC	Branch connection (2)
		RF_TEE	Reinforced fabricated tee
		URF_TEE	Unreinforced fabricated tee
	2010	WLD	Welding Tee per ANSI B19.6
		RF_TEE	Reinforced fabricated tee
		BRC	Branch connection or unreinforced fabricated tee
		WLD_BRC	Fillet welded and partial penetration welded branch connections
ASME_NB	1992	WLD	Butt welding tees
		BRC	Branch connections per NB-3643
	2010	WLD	Butt welding tees
		BRC	Branch connections per NB-3643
EN	2002	URF_TEE	tee with welded-on, welded-in or extruded nozzle
		RF_TEE	tee with welded-on, welded-in or extruded nozzle with additional reinforcing ring
		WLD	forged welded-in tee
		BRC	particular connections
ASME_B314	2006	WLD	Welding tee per ASME B16.9
		RF_TEE	Reinforced tee with pad or saddle
		URF_TEE	Unreinforced fabricated tee
		EX_OUT	Extruded welding tee

- DB** branch pipe outside diameter
- type: [REAL](#)  
unit: mm  
default value: outside diameter set in the cross-section of adjacent pipe from the BRANCH side  
limitations: > 0 + see Appendix 2
- TB** branch pipe wall thickness

	type: <a href="#">REAL</a> unit: mm default value: wall thickness set in the cross-section of adjacent pipe from the BRANCH side limitations: $TB > 0$ ; $DB - 2 * TB > 0$ + see Appendix 2
<b>DR</b>	run pipe outside diameter
	type: <a href="#">REAL</a> unit: mm default value: outside diameter of the RUN pipe limitations: $> 0$ + see Appendix 2
<b>TR</b>	run pipe wall thickness
	type: <a href="#">REAL</a> unit: mm default value: wall thickness of the RUN pipe limitations: $TR > 0$ ; $[DR - 2 * (TR - CR)] > 0$ + see Note 2
<b>CR<sup>1)</sup></b>	combined mill tolerance and corrosion allowance for the RUN pipe
	type: <a href="#">REAL</a> unit: mm default value: inherits value from the RUN pipe cross-section data limitations: $CR \geq 0$ , $TR - CR > 0$
<b>CB<sup>1)</sup></b>	combined mill tolerance and corrosion allowance for the BRANCH pipe
	type: <a href="#">REAL</a> unit: mm default value: inherits value from the BRANCH pipe cross-section data limitations: $CB \geq 0$ , $TB - CB > 0$
<b>TW</b>	reinforcement of the branch in the zone of welding (see <a href="#">Figure</a> )
	type: <a href="#">REAL</a> unit: mm default value: TB limitations: $\geq TB$
<b>TN</b>	wall thickness of nozzle or branch connection reinforcement ; it is used for 'BRC' or WLD_'BRC' type
	type: <a href="#">REAL</a> unit: mm default value: TB limitations: $\geq TB$
<b>RP</b>	outside radius of reinforced nozzle or branch connection; it is used for a tee of 'BRC' and WLD_'BRC' type (see <a href="#">Appendix XI, Figure NC-3673.2(b)-2</a> )

type: [REAL](#)  
 unit: mm  
 default value: TB  
 limitations:  $\geq$  TB

**R2** radius of rounding in the region of branch connection; it is used for a tee of 'BRC' type (see [Appendix XI, Figure NB-3643.3\(a\)-1](#))

type: [REAL](#)  
 unit: mm  
 default value: TB  
 limitations:  $\geq$  TB

**TE** thickness of the Pad or reinforcement; it is used for a tee of 'RF\_TEE' type (see [Appendix XI, Figure NC-3673.2\(b\)-2](#))

type: [REAL](#)  
 unit: mm  
 default value: TB  
 limitations:  $\geq$  TB

**SI (10)** array of stress indexes, which are interpreted by the program depending upon the Stress Code being used, see the following table:

CODE	(1)	(2)	(3)	(4)	(5)	(6)	(7)	(8)	(9)	(10)
PNAE, PNAE_T	$K_{U(S)}$	$a_s$								
ASME_NC	$B_1$	$B_{2R}$	$B_{2B}$	$S_{IR}$	$S_{IB}$	$B_{2R}'$	$B_{2B}'$			
ASME_NB	$C_1$	$K_1$	$B_{2R}$	$B_{2B}$	$C_{2R}$	$C_{2B}$	$K_{2R}$	$K_{2B}$	$B_{2R}'$	$B_{2B}'$
EN	$S_{IR}$	$\frac{S_{IR}^{*0.7}}{5}$	$S_{IB}$	$\frac{S_{IB}^{*0.7}}{5}$						
ASME_B311	$S_I$	$S_I^{*0.75}$								

type: [REAL](#)  
 unit: -  
 default value: to be determined by the program automatically  
 limitations:  $SI(1) \geq 2$  ;  $SI(2) \geq 1$  (for PNAE Codes)

**NOTE** Element ID

type: [STRING](#)  
 unit: -  
 default value: [blank](#)  
 limitations: see limitations for the string values of parameters, the length shall not be more than 32 characters

*Note:*

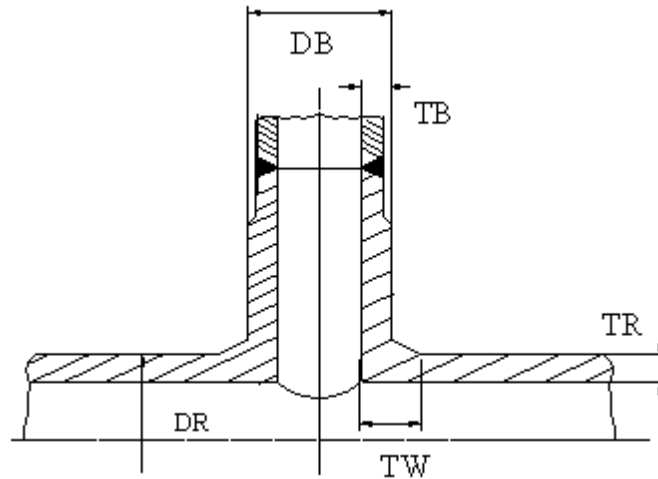

**Cross-section of the tee joint (Russian PNAE Code)**

- 1) *CR and TW parameters are used only for PNAE and RD Codes; CB parameter is used only for RD.*
- 2) *The diameter and thickness of the RUN (DR, TR) and BRANCH (DB, TB) cannot be less than similar parameters for the pipes being connected*

Example:

2000: TEE DB 108 TB 9 DR 325 TR 16

## "Standard" (TEE)

**Type:** local geometrical command

**Function:** Command for setting the characteristics of the standard tee/branch connection joints. Data for such fitting should be previously defined in the pipe sections (see [&TEE](#) subcommand). Elements that form header pipe should be located inline. Branch pipe should be orthogonal to the header pipe. Allowable tolerances from above angles are defined by [TBRC\\_TOL](#) and [TRUN\\_TOL](#) parameters.

**Parameters:**

**ID** identification name of the standard fitting. It could be set from the available set appeared in the drop down list (required parameter)

type:	<a href="#">TEXT</a>
units:	-
default value:	-
limitations:	see <a href="#">&amp;TEE</a> subcommand

**BP** Reference to the existing node located on the branch pipe. BP is optional parameter that could be used to set collectors, pipe crosses, etc.:

Watch Video

type: [TEXT](#)  
 units: -  
 default value: -  
 limitations: existing node

**CODE** Reference on strength analysis code (applicable only for CODE = 'NTD\_ASI')

type: [TEXT](#)  
 units: -  
 default value: [CODE](#)  
 limitations: same as [CODE](#)

**CODE\_YEAR** year of publication of the codes (edition)

type: [INTEGER](#)  
 units: -  
 default value: [CODE\\_YEAR](#)  
 limitations: same as [CODE\\_YEAR](#)

**NOTE** Element ID

type: [STRING](#)  
 unit: -  
 default value: [blank](#)  
 limitations: see limitations for the string values of parameters, the length shall not be more than 32 characters

Example:

```
20: TEE id = 'BRC'
```

## Stress Indexes

These tabs show stress intensification factors/stress indexes calculated by the program depending on the CODE used for stress analysis. By default, the coefficients are calculated in accordance with the requirements of the Norms, but if one uncheck the “calculated by program” checkbox, these coefficients may be redefined by User.

### [BEND/ELBOW:](#)

CODE = 'ASME\_NC', 'EN'

CODE = 'ASME\_NB', CLS = 1

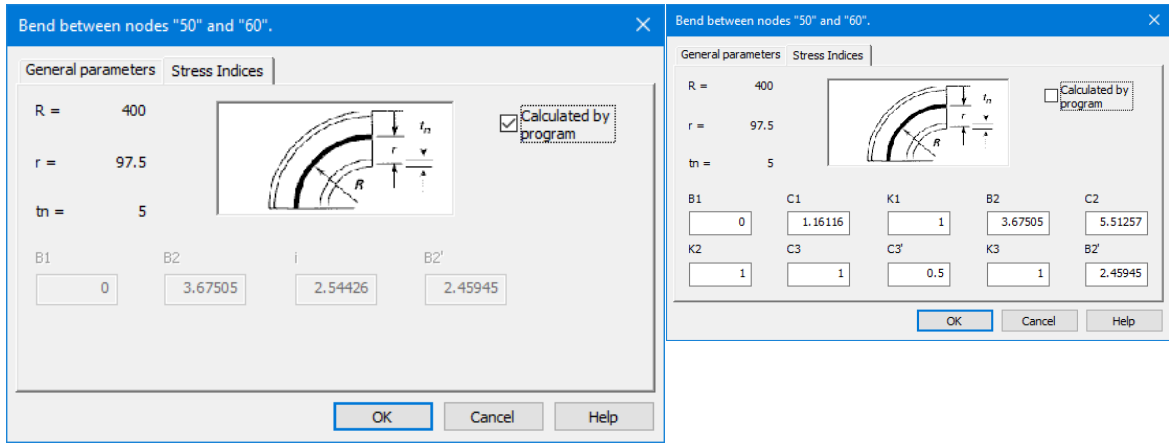

**MITER BEND:**

CODE = 'ASME\_NC'

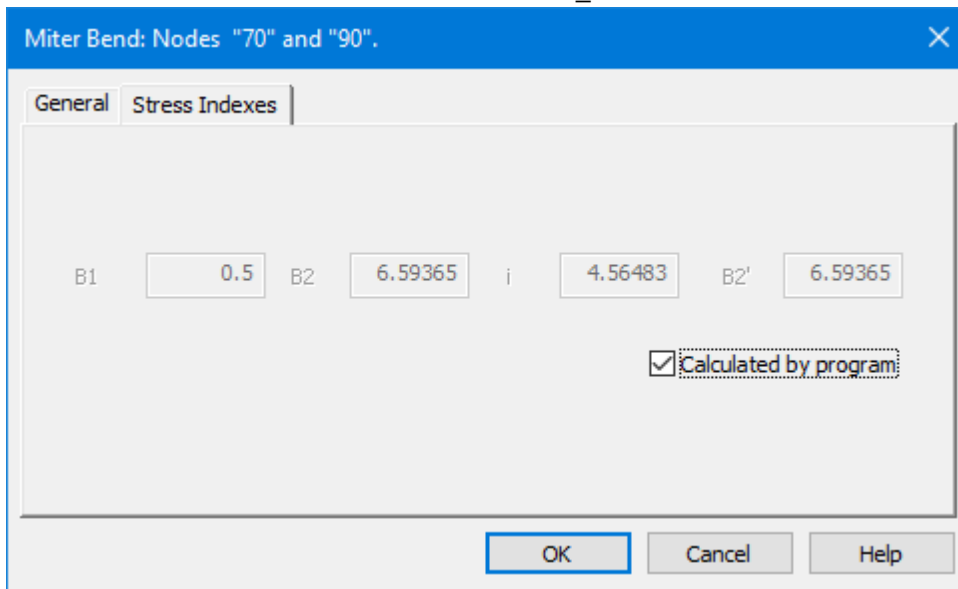

**REDUCER**

CODE = 'ASME\_NC', 'EN'

CODE = 'ASME\_NB', CLS = 1

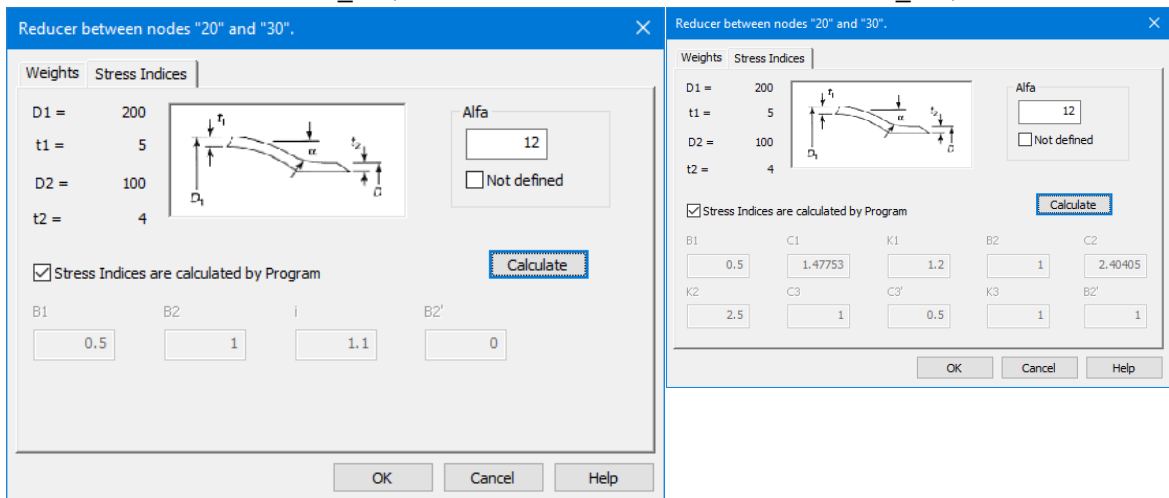

**WELD**

CODE = 'ASME\_NC', 'EN'

CODE = 'ASME\_NB', CLS = 1

Weld in node "10". Code: ASME\_NC.

Node  Type

Stress Indices

B1  B2  i  B2'

Calculated by program

Designation

Comment

Deactivate

Weld in node "10". Code: ASME\_NB.

Node  Type

Stress Indices

B1  C1  K1  B2  C2

K2  C3  C3'  K3  B2'

Calculated by program

Designation

Comment

Deactivate

If these data are redefined by USER, they are recorded in dp5 file in the SI array:

CODE	1	2	3	4	5	6	7	8	9	10
ASME_NB	<b>B1</b>	<b>C1</b>	<b>K1</b>	<b>B2</b>	<b>C2</b>	<b>K2</b>	<b>C3</b>	<b>C3'</b>	<b>K3</b>	<b>B2'</b>
ASME_NC	<b>B1</b>	<b>B2</b>	<b>i</b>	<b>B2'</b>						
EN	<b>i</b>	<b>0.75*i</b>								
ASME B31.1	<b>i</b>	<b>0.75*i</b>								

## Welds (WLD)

Weld in node "210". Code: ASME\_NC.

Node  Type

Stress Indices

B1  B2  i

Calculated by program

Comment

Deactivate

**type**: local geometrical command

**Function:** setting stress indexes for circumferential welding, Parameters are set depending on CODE.

**Parameters:**

**FIB** strength reduction factor

type: [REAL](#)  
 unit: -  
 default value: 0.9  
 limitations:  $0 < \text{FIB} \leq 1$

**FWS** fatigue strength reduction factor (to be determined in accordance with Item 5.6.12 of Codes [\[REF 1\]](#), it is applicable in case when [CODE](#) = 'PNAE' and 'PNAE\_T')

type: [REAL](#)  
 unit: -  
 default value: 0.9  
 limitations:  $0 < \text{FWS} \leq 1$

**TYPE** type of material of the piping (to be used for RD and PNAE codes - high temperature piping systems)

type: [TEXT](#)  
 unit: -  
 default value: 'CS'  
 limitations: 'AUS', 'CMV', 'CS', 'BWELD', 'SOCK', 'TRANS'

When using ASME/EN CODES, an additional fields with [stress indexes](#) appears in the dialog

**Note:**

*In evaluating the piping system strength according to RD 10-249-98 codes [\[REF 2\]](#), the values of strength reduction factors for welded joints shall be taken according to Table 4.2 depending upon the TYPE parameter. When TYPE='AUS' the austenite chromium-nickel and high-chromium steels are considered; TYPE='CMV' corresponds to chromium-molybdenum steels; TYPE='CS' – to carbon, manganese and chromium-molybdenum steels. Types 'BWELD' (Girth Butt Weld), 'SOCK' (Socket Weld) and 'TRANS' (Transition) are used in frame of ASME and EN analyses.*

**Example:**

```
2000: WLD FIB 0.9 FWS 1
```

or

```
2000: WLD TYPE 'CS'
```

## Concentrated weight (CW)

**type:** local geometrical command

**Function:** setting the weight in the node

### Parameters:

**W** concentrated weight

type: [REAL](#)  
 unit: Newton  
 default value: 0  
 limitations:  $\geq 0$

**OFF(3)** offset of the weight load (relative coordinates, X, Y, Z, shall be set along the direction of global axes)

type: [REAL](#)  
 unit: mm  
 dimension: array of three numbers  
 default value: 0, 0, 0  
 limitations: -

### Note:

- 1) *In dynamic analysis, the concentrated weight is interpreted as a concentrated mass over all translational degrees of freedom. See also [Appendix IV](#).*

Example:

2000: CW 1000.

## Concentrated Loads (FOR)

**Nodal Forces and Moments**

Node: 121

Operation Modes: \$COLD, SAMX, SAMY, SAMZ

Modes in use: OPER

**Force**

Direction  Components Value: 1414.21

Coordinate System:  3D  X  Y  Z

Global  Fx: 0  Fy: 1000  Fz: 1000

**Moment**

Direction  Components Value: 0

Coordinate System:  3D  X  Y  Z

Global  Mx: 0  My: 0  Mz: 0

Deactivate

**type:** local geometrical multi-line command

**Function:** command for applying the forces/moments concentrated in the node<sup>1)</sup>

**Parameters:**

**MODE** - identification name of the corresponding operating mode

type:	<a href="#">TEXT</a>
unit:	-
default value:	-
limitations:	see limitations for the text values of parameters. The operating mode shall preliminarily be described by the <a href="#">OPVAL</a> command

**FX, FY, FZ** Components of forces acting along global axes

type:	<a href="#">REAL</a>
unit:	N
default value:	-
limitations:	-

**MX, MY, MZ** Components of moments acting along global axes

type:	<a href="#">REAL</a>
unit:	N*mm
default value:	-
limitations:	-

or:

**F (M)** force's (moments') magnitude

type:	<a href="#">REAL</a>
unit:	N (N*mm)
default value:	-
limitations:	-

+

**DC\_F (DC\_M)<sup>2)</sup>** projections of the line of action of the force (moment) on the global coordinates XYZ, or the corresponding direction cosines.

type:	<a href="#">REAL</a>
unit:	-
dimension:	array of three elements
default value:	-
limitations:	all three elements of the array cannot simultaneously be equal to zero.

**DIRL\_F (DIRL\_M)<sup>2)</sup>** alternative way for specification of load's directions (in local coordinates)

type:	<a href="#">REAL</a> or <a href="#">TEXT</a>
unit:	-
dimension:	array of three elements
default value:	-
limitations:	Either 3 numbers are directional cosines, or 'A', 'H', 'N' - directions of local axes

**DS\_F (DS\_M)<sup>2)</sup>** alternative way for specification of load's directions (in spherical coordinates). See command [DS](#)

type:	<a href="#">REAL</a>
units:	-
dimension:	array of three elements
default value:	-
limitations:	both elements of the array cannot simultaneously be equal to zero.

Example:

```
DJ10N: FOR
& mode = 'HOT',    fz = 2000
& mode = 'REG_1',  fz = 1000
& mode = 'REG_2',  fz = 20
```

**Note:**

- 1) To activate concentrated loads within current analysis the corresponding reference shall be specified in the [SOLV](#) command: ... LC MOD='\$OPER' ... **LOAD** = 'W+P+F'
- 2) Parameters specifying the load's directions: DC\_, DIRL\_ and DS\_, are mutually exclusive. To define the local coordinate system, see [Appendix II](#)

**Anchor (ANC)**

Anchor

General | Movements | Loads | ← DBS\_TBL, DBS\_REF

Node: 4640

Translational Stiffness

X	Y	Z
1E+009	1E+009	1E+009
<input checked="" type="checkbox"/> Default	<input checked="" type="checkbox"/> Default	<input checked="" type="checkbox"/> Default

Coordinate System

Global  Local

Fj°: 0 Theta°: 0

**GROUP/CNODE**

Seismic Group/Connection Node

Node  Group

Seismic Group: UJA\_8\_16\_22\_5

**OUT**

Output THA Results

Releases: No REL

Designation: \$\$ Upper Reactor Nozzle **NOTE**

Comment:

Deactivate

OK Cancel Help

**type:** local geometrical multi-line command

**Function:** model an anchor (fixed support)

**Parameters:**

**STX(STA)** anchor stiffness in the direction of global X axis (STX) or local A axis (STA)

type: [REAL](#)  
 unit: N/mm  
 default value: [rigid](#)  
 limitations:  $\geq 0$

**STY(STH)** anchor stiffness in the direction of global Y axis (STY) or local H axis (STH)

type: [REAL](#)  
 unit: N/mm  
 default value: [rigid](#)  
 limitations:  $\geq 0$

**STZ(STN)** anchor stiffness in the direction of global Z axis (STZ) or local N axis (STN)

type: [REAL](#)  
 unit: N/mm  
 default value: [rigid](#)  
 limitations:  $\geq 0$

**SRX(SRA)** angular spring rate of the anchor about the global X axis (SRX) or local A axis (SRA)

type: [REAL](#)  
 unit: N\*mm/rad  
 default value: [rigid](#)  
 limitations:  $\geq 0$

**SRY(SRH)** angular spring rate of the anchor about the global Y axis (SRY) or local H axis (SRH)

type: [REAL](#)  
 unit: N\*mm/rad  
 default value: [rigid](#)  
 limitations:  $\geq 0$

**SRZ(SRN)** angular spring rate of the anchor about the global Z axis (SRZ) or local N axis (SRN)

type: [REAL](#)  
 unit: N\*mm/rad  
 default value: [rigid](#)  
 limitations:  $\geq 0$

**REL**<sup>3)</sup> release degrees of freedom at the determination of loads on hangers

type: [TEXT](#)  
 unit: -  
 default value: -  
 limitations: see Note 3

<b>NOTE</b>	support ID	
	type:	<a href="#">STRING</a>
	unit:	-
	default value:	<a href="#">blank</a>
	limitations:	see limitations for the string values of parameters, the length shall not be more than 32 characters
<b>GROUP</b> <sup>4)</sup>	name of the seismic group of supports	
	type:	<a href="#">TEXT</a>
	unit:	-
	default value:	name of the first group of spectra described by the <a href="#">SPEC</a> command
	limitations:	name of the group to be selected from the 'GROUP' parameter of the <a href="#">SPEC</a> command
<b>CNODE</b> <sup>4,5)</sup>	connecting node	
	type:	<a href="#">TEXT</a>
	unit:	-
	default value:	-
	limitations:	the parameter shall refer to the label of one of the existing nodes of the analytical model
<b>OUT</b> <sup>6)</sup>	write the "time - force - deformation" records in a text file (available only for THA: <a href="#">DYN</a> ='THA')	
	type:	<a href="#">TEXT</a>
	unit:	-
	default value:	'NO'
	limitations:	'YES' or 'NO'
<b>FI</b>	angle of rotation of the anchor global axes about Z axis (similar to the DS(1) angle of the <a href="#">spherical coordinate system</a> )	
	type:	<a href="#">REAL</a>
	unit:	degrees
	default value:	0
	limitations:	≥ 0
<b>THETA</b>	angle of rotation of the turned X axis of the anchor with respect to the horizontal plane (similar to the DS(2) angle of the <a href="#">spherical coordinate system</a> )	
	type:	<a href="#">REAL</a>
	unit:	degrees
	default value:	0
	limitations:	≥ 0

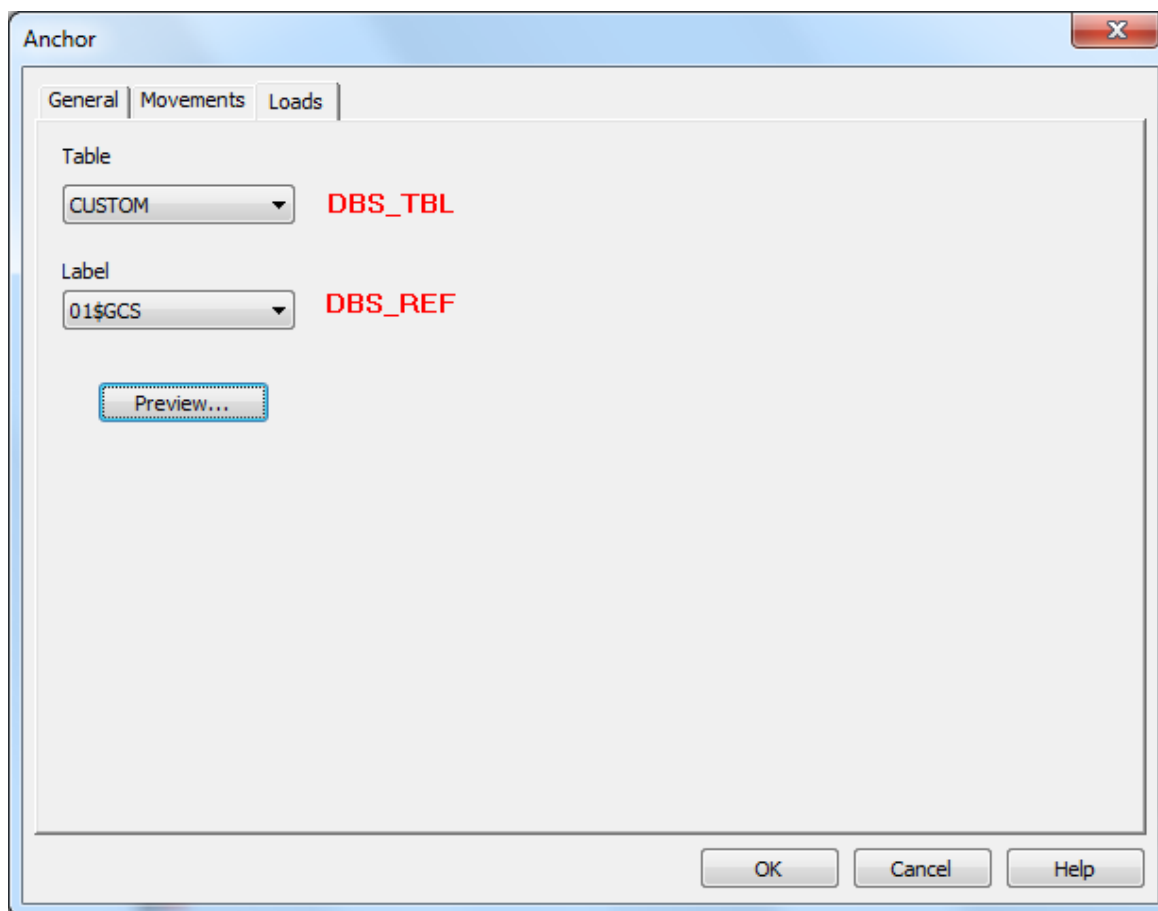

**DBS\_TBL**            reference to the table in [DB for supports](#)

type:                    [STRING](#)  
 unit:                    -  
 default value:         -  
 limitations:            existing table in DB

**DBS\_REF**            reference to the record from the DBS\_TBL table

type:                    [STRING](#)  
 unit:                    -  
 default value:         -  
 limitations:            existing mark

#### Parameter subcommand

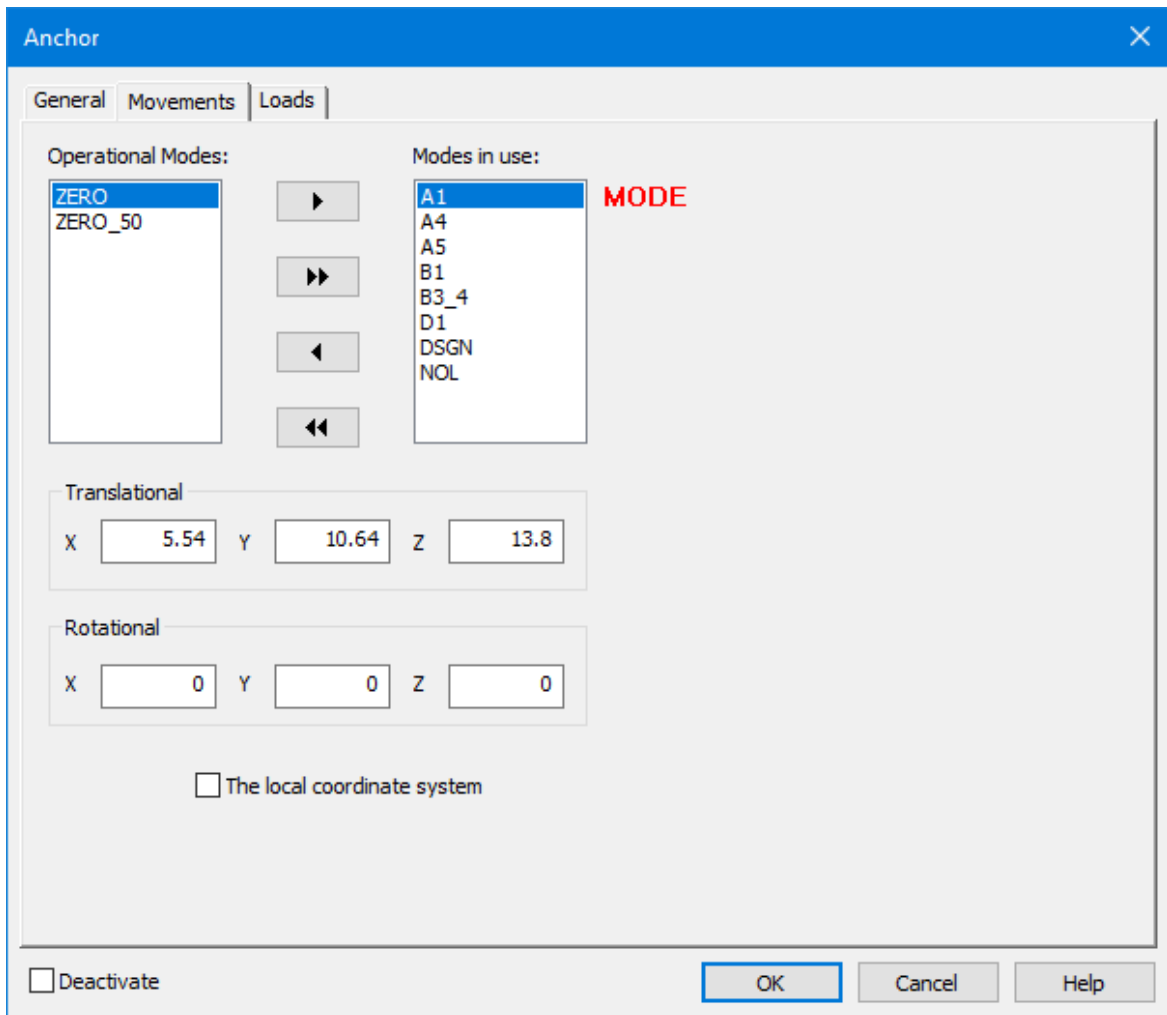

**MODE** - identification name of the piping system operating mode. It is used for setting the pre-defined displacement of anchors

type: [TEXT](#)  
 unit: -  
 default value: -  
 limitations: see limitations for the text values of parameters. The operating mode shall preliminarily be described by the [OPVAL](#) command

**Subcommand parameter :**

**DX** anchor displacement along the global X axis

type: [REAL](#)  
 unit: mm  
 default value: 0  
 limitations: -

**DY** anchor displacement along the global Y axis

type: [REAL](#)

unit: mm  
 default value: 0  
 limitations: -

**DZ** anchor displacement along the global Z axis

type: [REAL](#)  
 unit: mm  
 default value: 0  
 limitations: -

**RX** angular displacement of the anchor about the global X axis

type: [REAL](#)  
 unit: rad  
 default value: 0  
 limitations: -

**RY** angular displacement of the anchor about the global Y axis

type: [REAL](#)  
 unit: rad  
 default value: 0  
 limitations: -

**RZ** angular displacement of the anchor about the global Z axis

type: [REAL](#)  
 unit: rad  
 default value: 0  
 limitations: -

**Note:**

- 1) Local coordinate system used for supports is defined according to the rules set forth in [Appendix II](#);
- 2) The ANC command cannot be set in the middle of the span;
- 3) The **REL** parameter is taken into account only in selecting the spring characteristics, namely, at the stage of analysis, for which the **TYPE = 'DSGN'** parameter is set in the [SOLV](#) command. The possible variants of values of the REL parameter are as follows: 'V' - release the vertical; 'T' - release all translational degrees of freedom (X, Y, Z/ A, H, N); 'A' - release all;
- 4) The **GROUP** and **CNODE** parameters are mutually exclusive;
- 5) **CNODE** can be used to tie one node in the piping system to any other node in the system. If **CNODE** is set no anchor movement could be defined
- 6) With the parameter value of **OUT = 'YES'**, a file with the name of "SUPP\_001\_100.dat" type will appear in the directory of the model after execution of the analysis. In the file name: "100" is the node name, "001" -is the sequence number of the anchor or **FIX** support located in the "100" node. The file contains 13 columns of numbers: first column - time, 2nd - 7th columns - components of forces in the anchor/support (Fx, Fy, Fz, Mx, My, Mz); 8th - 13th columns - dynamic deformations of the anchor/support (Dx, Dy, Dz, Rx, Ry, Rz).

**Example:**

```
2000: ANC REL 'V'
& mode 'NOL' DX -10. DY -23. DZ 30. RX 3.
```

```
& mode 'ZERO'
& mode 'HYDR' DX -5. DY -13. DZ 20.
```

## Support (SUP)

Support

General | Movements | Loads

Node: 110 Reference: Pipe (110->7300)

Translational Stiffness

X	Y	Z
1E+009	1E+009	1E+009
<input checked="" type="checkbox"/> Default	<input checked="" type="checkbox"/> Default	<input checked="" type="checkbox"/> Default

Coordinate System

Global  Local

Fi°: 0 Theta°: 0

Rotational Stiffness

X	Y	Z
1E+014	1E+014	1E+014
<input checked="" type="checkbox"/> Default	<input checked="" type="checkbox"/> Default	<input checked="" type="checkbox"/> Default

Seismic Group/Connection Node

Node  Group

Seismic Group: UJA\_8\_16\_22\_5

Output THA Results

Designation: 10JMK01BQ003 NOTE

Comment:

Deactivate

OK Cancel Help

**type:** local geometrical command

**Function:** model fixed support, unlike anchor could be placed in the piping mid-span

### Parameters:

**STX(STA)** support stiffness in the direction of the global X axis (STX) or local A axis (STA)

type: [REAL](#)  
 unit: N/mm  
 default value: [rigid](#)  
 limitations:  $\geq 0$

**STY(STH)** support stiffness in the direction of the global Y axis (STY) or local H axis (STH)

type: [REAL](#)  
 unit: N/mm

	default value:	<a href="#">rigid</a>
	limitations:	$\geq 0$
<b>STZ(STN)</b>	support stiffness in the direction of the global Z axis (STZ) or local N axis (STN)	
	type:	<a href="#">REAL</a>
	unit:	N/mm
	default value:	<a href="#">rigid</a>
	limitations:	$\geq 0$
<b>SRX(SRA)</b>	angular spring rate of the support about the global X axis (SRX) or local A axis (SRA)	
	type:	<a href="#">REAL</a>
	unit:	N*mm/rad
	default value:	<a href="#">rigid</a>
	limitations:	$\geq 0$
<b>SRY(SRH)</b>	angular spring rate of the support about the global Y axis (SRY) or local H axis (SRH)	
	type:	<a href="#">REAL</a>
	unit:	N*mm/rad
	default value:	<a href="#">rigid</a>
	limitations:	$\geq 0$
<b>SRZ(SRN)</b>	angular spring rate of the support about the global Z axis (SRZ) or local N axis (SRN)	
	type:	<a href="#">REAL</a>
	unit:	N*mm/rad
	default value:	<a href="#">rigid</a>
	limitations:	$\geq 0$
<b>NOTE</b>	support ID	
	type:	<a href="#">STRING</a>
	unit:	-
	default value:	<a href="#">blank</a>
	limitations:	see limitations for the string values of parameters, the length shall not be more than 32 characters
<b>GROUP<sup>2)</sup></b>	name of the seismic group of supports	
	type:	<a href="#">TEXT</a>
	unit:	-
	default value:	name of the first group of spectrums described by the <a href="#">SPEC</a> command
	limitations:	the group name is selected from the 'GROUP' parameter of the <a href="#">SPEC</a> command
<b>CNODE<sup>2,3)</sup></b>	connecting node	

type: [TEXT](#)  
 unit: -  
 default value: -  
 limitations: the parameter shall refer to the label of one of the existing nodes of the analytical model

**OUT<sup>4</sup>** write the "time - force - deformation" records in a text file (available only for THA: [DYN='THA'](#))

type: [TEXT](#)  
 unit: -  
 default value: 'NO'  
 limitations: 'YES' or 'NO'

**FI** angle of rotation of the anchor global axes about Z axis (similar to the DS(1) angle of the [spherical coordinate system](#))

type: [REAL](#)  
 unit: degrees  
 default value: 0  
 limitations:  $\geq 0$

**THETA** angle of rotation of the turned X axis of the anchor with respect to the horizontal plane (similar to the DS(2) angle of the [spherical coordinate system](#))

type: [REAL](#)  
 unit: degrees  
 default value: 0  
 limitations:  $\geq 0$

**DBS\_TBL** reference to the table in [DB for supports](#)

type: [STRING](#)  
 unit: -  
 default value: -  
 limitations: existing table in DB

**DBS\_REF** reference to the record from the DBS\_TBL table

type: [STRING](#)  
 unit: -  
 default value: -  
 limitations: existing mark

### Subcommand

**type:** subcommand

**Function:** to be used for setting the pre-defined displacements of the supports

**Parameters:**

**MODE** - identification name of the piping system operating mode.

type:	<a href="#">TEXT</a>
unit:	-
default value:	-
limitations:	see limitations for the text values of parameters. The operating mode shall preliminarily be described by the <a href="#">OPVAL</a> command

**DX** support displacement along the global X axis

type:	<a href="#">REAL</a>
unit:	mm
default value:	0
limitations:	-

**DY** support displacement along the global Y axis

type:	<a href="#">REAL</a>
unit:	mm
default value:	0
limitations:	-

**DZ** support displacement along the global Z axis

type:	<a href="#">REAL</a>
unit:	mm
default value:	0
limitations:	-

**RX** angular displacement of the support about the global X axis

type:	<a href="#">REAL</a>
unit:	rad
default value:	0
limitations:	-

**RY** angular displacement of the support about the global Y axis

type:	<a href="#">REAL</a>
unit:	rad
default value:	0
limitations:	-

**RZ** angular displacement of the support about the global Z axis

type:	<a href="#">REAL</a>
unit:	rad
default value:	0
limitations:	-

**Note:**

- 1) Local coordinate system used for supports is defined according to the rules set forth in [Appendix II](#);
- 2) The GROUP and CNODE parameters are mutually exclusive;
- 3) CNODE can be used to tie one node in the piping system to any other node in the system. If CNODE is set no support's movement could be defined
- 4) With the parameter value of OUT = 'YES', a file with the name of "SUPP\_001\_100.dat" type will appear in the directory of the model after execution of the analysis. In the file name: "100" is the node name, "001" -is the sequence number of the anchor or FIX support located in the "100" node. The file contains 13 columns of numbers: first column - time, 2nd - 7th columns - components of forces in the anchor/support (Fx, Fy, Fz, Mx, My, Mz); 8th - 13th columns - dynamic deformations of the anchor/support (Dx, Dy, Dz, Rx, Ry, Rz).

Example:

2000: SUP SRA 0

## Translational Restraint (STS)

Restraint dialog box configuration:

- Node: 5320
- Displacement Type:  Translation,  Rotation
- Type of Support:  +/-,  +,  -
- Direction: Coordinate System  3D,  A,  H,  N
- Local:  dA,  dH,  dN
- Stiffness:  Default,  STIF
- Seismic Group/Connection Node:  Node,  Group, Seismic Group: UJA\_8\_16\_22\_5, GROUP/CNODE
- Gap:  GAP
- Friction:  MU
- OUT  Output THA Results
- REF\_NODE Reference: Pipe (300->5320)
- Designation: 30JNA.20BQ.4054 RRA, NOTE
- Comment:
- Deactivate
- Buttons: OK, Cancel, Help

type: local geometrical multi-line command

**Function:** restraint acting in both directions along the line of action (STS);<sup>1)</sup>

**Parameters:**

**STIF** restraint's stiffness

type: [REAL](#)  
 unit: N/mm  
 default value: [rigid](#)  
 limitations:  $\geq 0$

**DC or DS:** direction of the action of restraint; see "[Local commands](#)" section for the description of parameters

**GAP<sup>2)</sup>** gap

type: [REAL](#)  
 unit: mm  
 default value: 0  
 limitations:  $\geq 0$

**MU** friction coefficient

type: [REAL](#)  
 unit: -  
 default value: 0  
 limitations:  $0 \leq MU \leq 1$

**NOTE** Note/Restraint ID

type: [STRING](#)  
 unit: -  
 default value: [blank](#)  
 limitations: see limitations for the string values of parameters, the length shall not be more than 32 characters

**GROUP<sup>3)</sup>** name of the seismic group of supports

type: [TEXT](#)  
 unit: -  
 default value: name of the first group of spectrums described by the [SPEC](#) command  
 limitations: name of the group to be selected from the 'GROUP' parameter of the [SPEC](#) command

**CNODE<sup>3,4)</sup>** connecting node

type: [TEXT](#)  
 unit: -  
 default value: -  
 limitations: the parameter shall refer to the label of one of the existing nodes of the analytical model

**OUT<sup>5)</sup>** write the "time - force - deformation" records in a text file (available only for THA: [DYN='THA'](#))

type: [TEXT](#)  
 unit: -  
 default value: 'NO'  
 limitations: 'YES' or 'NO'

**DBS\_TBL** reference to the table in [DB for supports](#)

type: [STRING](#)  
 unit: -  
 default value: -  
 limitations: existing table in DB

**DBS\_REF** reference to the record from the DBS\_TBL table

type: [STRING](#)  
 unit: -  
 default value: -  
 limitations: existing mark

### Subcommand

**type:** subcommand

**Function:** to be used for setting the pre-defined displacements of the restraint

### Parameters:

**MODE** identification name of the piping system operating mode

type: [TEXT](#)  
 unit: -  
 default value: -  
 limitations: see limitations for the text values of parameters. The operating mode shall preliminarily be described by the [OPVAL](#) command

**DX** restraint's displacement along the global X axis

type: [REAL](#)  
 unit: mm  
 default value: 0  
 limitations: -

**DY** restraint's displacement along the global Y axis

type: [REAL](#)  
 unit: mm  
 default value: 0  
 limitations: -

**DZ**                    restraint's displacement along the global Z axis

type:                    [REAL](#)  
unit:                    mm  
default value:         0  
limitations:            -

**Note:**

- 1) *Short variants of the designation of this command are possible when the direction of action of the restraint coincides with the global coordinates (STX, STY, STZ commands) or with the local coordinates of the support (STA, STH, STN). In case when a short designation of commands is used, the parameters indicating the direction (DC or DS) are not used;*
- 2) *The gap is symmetric. The gap value is set from the piping centerline "zero" (unloaded) state;*
- 3) *The GROUP and CNODE parameters are mutually exclusive;*
- 4) *CNODE can be used to tie one node in the piping system to any other node in the system. If CNODE is set no restraint's movement could be defined*
- 5) *With the parameter value of OUT = 'YES', a file with the name of "RSTR\_001\_100.dat" type will appear in the directory of the model after execution of the analysis. In the file name: "100" is the node name, "001" -is the sequence number of the one-component support located in the "100" node. The file contains 7 columns of numbers: first column - time, 2nd - 4th columns - components of forces in the support (Fx, Fy, Fz); 5th - 7th columns - dynamic deformations of the support (Dx, Dy, Dz).*

Example :

```
2000: STS 1.e4 DC 1 1 0 GAP 10 MU 0.3 NOTE "12RABQ001"
```

## One-way restraint ( STS+, STS- commands)

**type:** local geometrical multi-line command

**Function:** restraint acting in one directions along the line of action;

### Parameters:

**STIF** restraint's stiffness

type: [REAL](#)  
 unit: N/mm  
 default value: [rigid](#)  
 limitations:  $\geq 0$

**DC or DS:** direction of the action of support; see ["Local commands" section](#) for the description of parameters

**GAP<sup>2)</sup>** gap

type: [REAL](#)  
 unit: mm  
 default value: 0  
 limitations:  $\geq 0$

**MU** friction coefficient

type: [REAL](#)  
 unit: -  
 default value: 0  
 limitations:  $0 \leq MU \leq 1$

**NOTE** note (Support ID)

type: [STRING](#)  
 unit: -  
 default value: [blank](#)  
 limitations: see limitations for the string values of parameters,  
 the length shall not be more than 32 characters

**GROUP**<sup>4)</sup> name of the seismic group of supports

type: [TEXT](#)  
 unit: -  
 default value: name of the first group of spectrums described by  
 the [SPEC](#) command  
 limitations: name of the group to be selected from the 'GROUP'  
 parameter of the [SPEC](#) command

**CNODE**<sup>4,5)</sup> connecting node

type: [TEXT](#)  
 unit: -  
 default value: -  
 limitations: the parameter shall refer to the label of one of the  
 existing nodes of the analytical model

**OUT**<sup>6)</sup> write the "time - force - deformation" records in a text file (available only for  
 THA: [DYN](#)='THA')

type: [TEXT](#)  
 unit: -  
 default value: 'NO'  
 limitations: 'YES' or 'NO'

**DBS\_TBL** reference to the table in [DB for supports](#)

type: [STRING](#)  
 unit: -  
 default value: -  
 limitations: existing table in DB

**DBS\_REF** reference to the record from the DBS\_TBL table

type: [STRING](#)  
 unit: -  
 default value: -  
 limitations: existing mark

### Subcommand

type: subcommand

**Function:** to be used for setting the pre-defined displacements of the restraint

**Parameters:**

**MODE** - identification name of the piping system operating mode.

type:	<a href="#">TEXT</a>
unit:	-
default value:	-
limitations:	see limitations for the text values of parameters. The operating mode shall preliminarily be described by the <a href="#">OPVAL</a> command

**DX** support displacement along the global X axis

type:	<a href="#">REAL</a>
unit:	mm
default value:	0
limitations:	-

**DY** support displacement along the global Y axis

type:	<a href="#">REAL</a>
unit:	mm
default value:	0
limitations:	-

**DZ** support displacement along the global Z axis

type:	<a href="#">REAL</a>
unit:	mm
default value:	0
limitations:	-

**Note:**

- 1) "+" or "-" sign indicates the direction, in which the restraint is acting. Short designations of this command are possible (without indication of the direction by means of the DIR command): in the global coordinate system: STX+/STX-, STY+/STY-, STZ+/STZ-. In case when the local coordinate system is used, the following commands are applied: STA+/STA-; STH+/STH-; STN+/STN-.
- 2) For one-way restraints the gap is considered in the direction of action of the support; in the opposite direction the gap is considered unlimited. The gap value is set from the "zero" (unloaded) state.
- 3) The supports of "STZ-" and "STN-" type (the latter - in case of location on the horizontal segment of the piping system with a slope of not more than 10°) are considered by the program as those carrying the weight load. In case of their uplift for a value exceeding the critical one (see the [LIFT](#) parameter) at the Load Cases of "OPER\_A" or "OPER\_B" type (see the [SOLV](#) command, [TYPE](#) parameter); at the subsequent stage of analysis of "SUST\_C" type, these supports are not taken into account.
- 4) The GROUP and CNODE parameters are mutually exclusive.
- 5) CNODE can be used to tie one node in the piping system to any other node in the system. If CNODE is set no restraint's movement could be defined

- 6) With the parameter value of `OUT = 'YES'`, a file with the name of `"RSTR_001_100.dat"` type will appear in the directory of the model after execution of the analysis. In the file name: `"100"` is the node name, `"001"` -is the sequence number of the one-component support located in the `"100"` node. The file contains 7 columns of numbers: first column - time, 2nd - 4th columns - components of forces in the support ( $F_x$ ,  $F_y$ ,  $F_z$ ); 5th - 7th columns - dynamic deformations of the support ( $D_x$ ,  $D_y$ ,  $D_z$ ).

Example :

```
2000: STS+ 1.e4 DC 1 1 0 GAP 10 MU 0.3 NOTE "12RABQ001"
```

or :

```
2000: STX+ 1.e4 GAP 10 MU 0.3 NOTE "12RABQ001"
```

## Skewed Restraint (SRS)

Restraint dialog box configuration:

- Node: 1440
- Displacement Type:  Translation,  Rotation
- Type of Support:  +/-,  +,  -
- Direction:
  - Coordinate System:  3D,  A,  H,  N
  - Local: 
    - dA:  dH:  dN:
- Stiffness:  Default,  STIF
- Seismic Group/Connection Node:
  - Node,  Group
  - Seismic Group: UJA\_8\_16\_22\_5
  - GROUP/CNODE
- Gap:  Friction:
- OUT:  Output THA Results
- REF\_NODE: Bend (1430->1440) Designation: 30JNA20BQ4058 NOTE
- Comment:
- Deactivate:
- Buttons: OK, Cancel, Help

type: local geometrical multi-line command

**Function:** restraint limiting the angular movements;

**Parameters:**

**STIF** angular spring rate of the restraint about its line of action

type: [REAL](#)  
 unit: N\*mm/rad  
 default value: [rigid](#)  
 limitations:  $\geq 0$

**DC or DS:** direction of the action of support; see "[Local commands](#)" section for the description of parameters

**NOTE** support ID

type: [STRING](#)  
 unit: -  
 default value: [blank](#)  
 limitations: see limitations for the string values of parameters, the length shall not be more than 32 characters

**GROUP<sup>2)</sup>** name of the seismic group of supports

type: [TEXT](#)  
 unit: -  
 default value: name of the first group of spectrums described by the [SPEC](#) command  
 limitations: name of the group to be selected from the 'GROUP' parameter of the [SPEC](#) command

**CNODE<sup>2,3)</sup>** connecting node

type: [TEXT](#)  
 unit: -  
 default value: -  
 limitations: the parameter shall refer to the label of one of the existing nodes of the analytical model

**OUT<sup>4)</sup>** write the "time - force - deformation" records in a text file (available only for THA: [DYN](#)='THA')

type: [TEXT](#)  
 unit: -  
 default value: 'NO'  
 limitations: 'YES' or 'NO'

**DBS\_TBL** reference to the table in [DB for supports](#)

type: [STRING](#)  
 unit: -  
 default value: -

	limitations:	existing table in DB
<b>DBS_REF</b>		reference to the record from the DBS_TBL table
	type:	<a href="#">STRING</a>
	unit:	-
	default value:	-
	limitations:	existing mark

### Subcommand

**type:** subcommand

**Function:** to be used for setting the pre-defined displacements of the supports

### Parameters:

**MODE** - identification name of the piping system operating mode

	type:	<a href="#">TEXT</a>
	unit:	-
	default value:	-
	limitations:	see limitations for the text values of parameters. The operating mode shall preliminarily be described by the <a href="#">OPVAL</a> command

**RX** angular displacement of the support about the global X axis

	type:	<a href="#">REAL</a>
	unit:	rad
	default value:	0
	limitations:	-

**RY** angular displacement of the support about the global Y axis

	type:	<a href="#">REAL</a>
	unit:	rad
	default value:	0
	limitations:	-

**RZ** angular displacement of the support about the global Z axis

	type:	<a href="#">REAL</a>
	unit:	rad
	default value:	0
	limitations:	-

### Note:

- 1) Short variants of the designation of this command are possible when the direction of action of the support coincides with the global coordinates (STX, STY, STZ commands) or with the local coordinates of the support (STA, STH, STN). In case when a short designation of commands is used, the parameters indicating the direction (DC or DS) are not used;
- 2) The GROUP and CNODE parameters are mutually exclusive;
- 3) CNODE can be used to tie one node in the piping system to any other node in the system. If CNODE is set no restraint's movement could be defined;

- 4) *With the parameter value of OUT = 'YES', a file with the name of "RSTR\_001\_100.dat" type will appear in the working directory of the model after execution of the analysis. In the file name: "100" is the node name, "001" -is the sequence number of the one-component support located in the "100" node. The file contains 7 columns of numbers: first column - time, 2nd - 4th columns - components of forces in the support (Mx, My, Mz); 5th - 7th columns - dynamic deformations of the support (Rx, Ry, Rz).*

Example :

```
2000: SRS 1.e4 DC 1 1 0 NOTE "12RABQ001"
```

or

```
2000: SRN
```

or

```
2000: SRZ
```

## Rigid Strut (STRT)

**Rigid Strut**

General | Movements | Loads | ← DBS TBL, DBS REF

Node: 220

Length: LEN 0

Stiffness: 1e+009  Default

REF\_NODE Reference: Pipe (5330->220)

Direction: DC/DS/DI/L

Coordinate System:  3D  A  H  N

Local  dA 0 dH 1 dN 0

Offset: OFFS(3)

dA 0 dH 0 dN 300

GROUP/CNODE

Seismic Group/Connection Node:  Node  Group UJA\_8\_16\_22\_5

OUT  Output THA results

Designation: 30JNA20BQ4052 NOTE

Comment:

Deactivate OK Cancel Help

**type:** local geometrical multi-line command

**Function:** modeling a restraint forming a rigid connection in axial direction between piping and structure. Ability to model the geometric nonlinearity due to short length of restraint.

**Parameters:**

**LEN** length of the rod

type: REAL  
 unit: mm  
 default value: 0

	limitations:	$\geq 0$
<b>STIF</b>	stiffness of the restraint	
	type:	<a href="#">REAL</a>
	unit:	N/mm
	default value:	<a href="#">rigid</a>
	limitations:	$\geq 0$
	<b>DC/DS/DIRL(3)</b> direction of the action of support in Cartesian/spherical or local coordinates; see <a href="#">"Local commands" section</a> for the description of parameters	
<b>OFFS(3)</b>	offsets of the point of restraint attachment to the pipe. Set in the local coordinates of pipe	
	type:	<a href="#">REAL(3)</a>
	unit:	mm
	dimension	array of three numbers
	default value:	0, 0, 0
	limitations:	-
<b>NOTE</b>	support ID	
	type:	<a href="#">STRING</a>
	unit:	-
	default value:	<a href="#">blank</a>
	limitations:	see limitations for the string values of parameters, the length shall not be more than 32 characters
<b>GROUP<sup>1)</sup></b>	name of the seismic group of supports	
	type:	<a href="#">TEXT</a>
	unit:	-
	default value:	name of the first group of spectrums described by the <a href="#">SPEC</a> command
	limitations:	name of the group to be selected from the 'GROUP' parameter of the <a href="#">SPEC</a> command
<b>CNODE<sup>1,2)</sup></b>	connecting node	
	type:	<a href="#">TEXT</a>
	unit:	-
	default value:	-
	limitations:	the parameter shall refer to the label of one of the existing nodes of the analytical model
<b>OUT<sup>3)</sup></b>	write the "time - force - deformation" records in a text file (available only for THA: <a href="#">DYN</a> ='THA')	
	type:	<a href="#">TEXT</a>
	unit:	-
	default value:	'NO'

	limitations:	'YES' or 'NO'
<b>DBS_TBL</b>	reference to the table in <a href="#">DB for supports</a>	
	type:	<a href="#">STRING</a>
	unit:	-
	default value:	-
	limitations:	existing table in DB
<b>DBS_REF</b>	reference to the record from the DBS_TBL table	
	type:	<a href="#">STRING</a>
	unit:	-
	default value:	-
	limitations:	existing mark

### Subcommand

**type:** subcommand

**Function:** to be used for setting the pre-defined displacements of the supports

### Parameters:

**MODE** - identification name of the piping system operating mode.

	type:	<a href="#">TEXT</a>
	unit:	-
	default value:	-
	limitations:	see limitations for the text values of parameters. The operating mode shall preliminarily be described by the <a href="#">OPVAL</a> command

**DX** support displacement along the global X axis

	type:	<a href="#">REAL</a>
	unit:	mm
	default value:	0
	limitations:	-

**DY** support displacement along the global Y axis

	type:	<a href="#">REAL</a>
	unit:	mm
	default value:	0
	limitations:	-

**DZ** support displacement along the global Z axis

	type:	<a href="#">REAL</a>
	unit:	mm
	default value:	0
	limitations:	-

**Note:**

- 1) The *GROUP* and *CNODE* parameters are mutually exclusive;
- 2) *CNODE* can be used to tie one node in the piping system to any other node in the system. If *CNODE* is set no restraint's movement could be defined;
- 3) With the parameter value of *OUT* = 'YES', a file with the name of "STRT\_001\_100.dat" type will appear in the working directory of the model after execution of the analysis. In the file name: "100" is the node name, "001" -is the sequence number of the one-component support located in the "100" node. The file contains 7 columns of numbers: first column - time, 2nd - 4th columns - components of forces in the support (*Mx*, *My*, *Mz*); 5th - 7th columns - dynamic deformations of the support (*Rx*, *Ry*, *Rz*).

**Example:**

```
50: STRT LEN = 1000, DC = 0, 0, 1 OFFS = 0, 123, 0 DBS_TBL = "LISEGA 2010RS", DBS
& MODE = 'NOL', DZ = 300
```

**Guide Support (STG, STG-)**

**type:** local geometrical multi-line command

**Function:** support restraining lateral movements of pipe.

**Parameters:**

**STIF** support's stiffness

	type: <a href="#">REAL</a> unit: N/mm default value: <a href="#">rigid</a> limitations: $\geq 0$
<b>MU</b>	friction coefficient
	type: <a href="#">REAL</a> unit: - default value: 0 limitations: $0 \leq MU \leq 1$
<b>NOTE</b>	Note / Comment
	type: <a href="#">STRING</a> unit: - default value: <a href="#">blank</a> limitations: see limitations for the string values of parameters, the length shall not be more than 32 characters
<b>GROUP</b> <sup>3)</sup>	name of the seismic group of supports
	type: <a href="#">TEXT</a> unit: - default value: name of the first group of spectrums described by the <a href="#">SPEC</a> command limitations: name of the group to be selected from the 'GROUP' parameter of the <a href="#">SPEC</a> command
<b>CNODE</b> <sup>3,4)</sup>	connecting node
	type: <a href="#">TEXT</a> unit: - default value: - limitations: the parameter shall refer to the label of one of the existing nodes of the analytical model
<b>OUT</b> <sup>5)</sup>	write the "time - force - deformation" records in a text file (available only for THA: <a href="#">DYN</a> ='THA')
	type: <a href="#">TEXT</a> unit: - default value: 'NO' limitations: 'YES' or 'NO'
<b>DBS_TBL</b>	reference to the table in <a href="#">DB for supports</a>
	type: <a href="#">STRING</a> unit: - default value: - limitations: existing table in DB
<b>DBS_REF</b>	reference to the record from the DBS_TBL table
	type: <a href="#">STRING</a>

unit:	-
default value:	-
limitations:	existing mark

### Subcommand

**type:** subcommand

**Function:** to be used for setting the pre-defined displacements of the supports

### Parameters:

**MODE** - identification name of the piping system operating mode.

type:	<a href="#">TEXT</a>
unit:	-
default value:	-
limitations:	see limitations for the text values of parameters. The operating mode shall preliminarily be described by the <a href="#">OPVAL</a> command

**DX** support displacement along the global X axis

type:	<a href="#">REAL</a>
unit:	mm
default value:	0
limitations:	-

**DY** support displacement along the global Y axis

type:	<a href="#">REAL</a>
unit:	mm
default value:	0
limitations:	-

**DZ** support displacement along the global Z axis

type:	<a href="#">REAL</a>
unit:	mm
default value:	0
limitations:	-

### Note:

- 1) The STG- command is not used at the vertical segment. At the piping segment with the direction different from the vertical, it is possible to use both forms of the STG command, e.g. "STG- mu" command is equivalent to the "STH mu" + "STN- mu" commands;
- 2) The support of "STG-" type located at the horizontal segment of the piping with a slope of not more than 10° is considered by the program as a support carrying the weight load. In case of its uplift for a value exceeding the critical one (see the [LIFT](#) parameter) at the analysis stages of "OPER\_A" or "OPER\_B" type (see the [SOLV](#) command, [TYPE](#) parameter), at the subsequent stage of analysis of "SUST\_C" type, this support will not be taken into account;
- 3) The GROUP and CNODE parameters are mutually exclusive;

- 4) *CNODE* can be used to tie one node in the piping system to any other node in the system. If *CNODE* is set no restraint's movement could be defined;
- 5) With the parameter value of *OUT = 'YES'*, a file with the name of "*RSTR\_001\_100.dat*" type will appear in the working directory of the model after execution of the analysis. In the file name: "*100*" is the node name, "*001*" -is the sequence number of the one-component support located in the "*100*" node. The file contains 7 columns of numbers: first column - time, 2nd - 4th columns - components of forces in the support (*Fx, Fy, Fz*); 5th - 7th columns - dynamic deformations of the support (*Dx, Dy, Dz*).

Example:

```
2000: STG MU 0.3
```

or:

```
2000: STG-
```

## Spring Hanger/Support (SPR)

Spring Hanger

General | Movements | Loads ← DBS\_TBL, DBS\_REF

Node: 370 Friction Factor: 0.1 MU

NC: 1 Number of chains: 1 Design: Support

TBL Catalogue: LISEGA

Spring Size: 8 Travel: 3

Chain Structure

Total Load: P Not Defined

GROUP/CNODE Seismic Group/Connection Node

Node Seismic Group

Group UJA\_8\_16\_22\_5

Default spring

Factors | Loads

Minimal load: 26660 PMIN Maximal load: 80000 PMAX Stiffness: 266.7 S

OUT  Output THA Results LOCK  Lock

Designation: 30JNA20BQ4155 SPS NOTE

Comment

Deactivate OK Cancel Help

**type:** local geometrical command

**Function:** simulating the spring hanger or spring support;

**Parameters:**

NC<sup>1)</sup> number of hangers/supports at the location

type: [INTEGER](#)

unit: -

default value: 1

limitations: |NC| ≥ 1

<b>P</b>	total hanger/support load
	type: <a href="#">REAL</a>
	unit: N
	default value: -
	limitations: $\geq 0$
<b>S</b>	spring rate (per one hanger/support)
	type: <a href="#">REAL</a>
	unit: N/mm
	default value: -
	limitations: $\geq 0$ (except for LC TYPE = <a href="#">'OPER_R'</a> )
<b>TBL -</b>	name of the spring Table
	type: <a href="#">TEXT</a>
	unit: -
	default value: to be determined in accordance with the parameters given in the database or indicated in the <a href="#">SDEF</a> command
	limitations: to be determined by the spring Table used (SH.DBS file)
<b>ID<sup>2)</sup></b>	spring identifier
	type: <a href="#">TEXT</a>
	unit: -
	default value: -
	limitations: to be determined by the spring Table used (SH.DBS file)
<b>PMAX</b>	maximum load per hanger/support
	type: <a href="#">REAL</a>
	unit: N
	default value: 0
	limitations: $\geq 0$
<b>PMIN</b>	minimum load per hanger/support
	type: <a href="#">REAL</a>
	unit: N
	default value: 0
	limitations: $\geq 0$
<b>LEN</b>	length of the hanger
	type: <a href="#">REAL</a>
	unit: mm
	default value: 0
	limitations: $\geq 0$
<b>PVAR</b>	load variation factor
	type: <a href="#">REAL</a>

	unit:	-
	default value:	0.35
	limitations:	$0 \leq PVAR \leq 1$
<b>PFAC</b>	load capacity factor	
	type:	<a href="#">REAL</a>
	unit:	-
	default value:	1.3
	limitations:	$PFAC \geq 1$
<b>ZMAX</b>	maximum structure of the chain	
	type:	<a href="#">INTEGER</a>
	unit:	-
	default value:	to be determined in accordance with the parameters given in the database or indicated in the <a href="#">SDEF</a> command
	limitations:	$ZMAX \geq 1$
<b>ZMIN</b>	minimum structure of the chain	
	type:	<a href="#">INTEGER</a>
	unit:	-
	default value:	to be determined in accordance with the parameters given in the database or indicated in the <a href="#">SDEF</a> command
	limitations:	$ZMIN \geq 1$
<b>NOTE</b>	Note / Support ID	
	type:	<a href="#">STRING</a>
	unit:	-
	default value:	<a href="#">blank</a>
	limitations:	see limitations for the string values of parameters, the length shall not be more than 32 characters
<b>GROUP</b> <sup>4)</sup>	name of the seismic group of supports	
	type:	<a href="#">TEXT</a>
	unit:	-
	default value:	name of the first group of spectrums described by the <a href="#">SPEC</a> command
	limitations:	name of the group to be selected from the 'GROUP' parameter of the <a href="#">SPEC</a> command
<b>CNODE</b> <sup>4,5)</sup>	connecting node	
	type:	<a href="#">TEXT</a>
	unit:	-
	default value:	-
	limitations:	the parameter shall refer to the label of one of the existing nodes of the analytical model

**OUT**<sup>6)</sup> write the "time - force - deformation" records in a text file (available only for THA:  
[DYN='THA'](#))

type: [TEXT](#)  
 unit: -  
 default value: 'NO'  
 limitations: 'YES' or 'NO'

**LOCK** lock spring during HT (Hydraulic Test during piping operational life, Load Case of [TEST\\_B](#) type)

type: [TEXT](#)  
 unit: -  
 default value: 'NO'  
 limitations: 'YES' or 'NO'

**DBS\_TBL** reference to the table in [DB for supports](#)

type: [STRING](#)  
 unit: -  
 default value: -  
 limitations: existing table in DB

**DBS\_REF** reference to the record from the DBS\_TBL table

type: [STRING](#)  
 unit: -  
 default value: -  
 limitations: existing mark

### Subcommand

**type:** subcommand

**Function:** to be used for setting the pre-defined displacements of the supports

### Parameters:

**MODE** - identification name of the piping system operating mode.

type: [TEXT](#)  
 unit: -  
 default value: -  
 limitations: see limitations for the text values of parameters. The operating mode shall preliminarily be described by the [OPVAL](#) command

**DX** support displacement along the global X axis

type: [REAL](#)  
 unit: mm  
 default value: 0  
 limitations: -

**DY** support displacement along the global Y axis

type:	<a href="#">REAL</a>
unit:	mm
default value:	0
limitations:	-

**DZ** support displacement along the global Z axis

type:	<a href="#">REAL</a>
unit:	mm
default value:	0
limitations:	-

**Note:**

- 1) At  $NC \geq 1$  the support will be displayed as a spring hanger; at  $NC \leq -1$  - as a spring support;
- 2) The spring identifier consists of 3 fields: 'size/travel/type' where the spring size corresponds to the maximum load on the spring, "travel" corresponds to the maximum possible working travel of the spring, hanger type is used only in those catalogues, in which same springs could be used in various design versions of variable spring supports (for example, LISEGA catalogue);
- 3) See also [Appendix VI](#) with comments on selecting springs for spring hangers/supports;
- 4) The GROUP and CNODE parameters are mutually exclusive;
- 5) CNODE can be used to tie one node in the piping system to any other node in the system. If CNODE is set no restraint's movement could be defined;
- 6) With the parameter value of OUT = 'YES', a file with the name of "SPRH\_001\_100.dat" type will appear in the working directory of the model after execution of the analysis. In the file name: "100" is the node name, "001" -is the sequence number of the one-component support located in the "100" node. The file contains 7 columns of numbers: first column - time, 2nd - 4th columns - components of forces in the support (Fx, Fy, Fz); 5th - 7th columns - dynamic deformations of the support (Dx, Dy, Dz).

Example :

```
2000: SPR NC 2 LEN 1000. NOTE "12RABQ003"
```

## Rod Hanger (ROD)

The screenshot shows the 'Rod Hanger' dialog box with the following fields and options:

- General Tab:**
  - Node: 370
  - Number of Rods: **NC** 2
  - Rod Length: **LEN** 1200
  - Stiffness: **STIF** 100000,  Default
  - Seismic Group/Connection Node:  Node,  Group, UJA\_8\_\_16\_\_22\_5
  - Output THA Results:
  - Designation: 30JNA20BQ4055 **NOTE**
  - Comment: (empty text box)
- Buttons:**  Deactivate, OK, Cancel, Help

**type:** local geometrical command

**Function:** modeling of the rigid rod hanger;

### Parameters:

<b>NC</b>	number of rods	
	type:	≥NT
	unit:	-
	default value:	1
	limitations:	≥ 1
<b>LEN</b>	length of hanger	
	type:	<a href="#">REAL</a>
	unit:	mm
	default value:	0
	limitations:	≥ 0
<b>STIF</b>	rod's stiffness	
	type:	<a href="#">REAL</a>

	unit:	N/mm
	default value:	<a href="#">RH_STF</a>
	limitations:	$\geq 0$
<b>NOTE</b>	support ID	
	type:	<a href="#">STRING</a>
	unit:	-
	default value:	<a href="#">blank</a>
	limitations:	see limitations for the string values of parameters, the length shall not be more than 32 characters
<b>GROUP<sup>2)</sup></b>	name of the seismic group of supports	
	type:	<a href="#">TEXT</a>
	unit:	-
	default value:	name of the first group of spectrums described by the <a href="#">SPEC</a> command
	limitations:	name of the group to be selected from the 'GROUP' parameter of the <a href="#">SPEC</a> command
<b>CNODE<sup>2,3)</sup></b>	connecting node	
	type:	<a href="#">TEXT</a>
	unit:	-
	default value:	-
	limitations:	the parameter shall refer to the label of one of the existing nodes of the analytical model
<b>OUT<sup>4)</sup></b>	write the "time - force - deformation" records in a text file (available only for THA: <a href="#">DYN='THA'</a> )	
	type:	<a href="#">TEXT</a>
	unit:	-
	default value:	'NO'
	limitations:	'YES' or 'NO'
<b>DBS_TBL</b>	reference to the table in <a href="#">DB for supports</a>	
	type:	<a href="#">STRING</a>
	unit:	-
	default value:	-
	limitations:	existing table in DB
<b>DBS_REF</b>	reference to the record from the DBS_TBL table	
	type:	<a href="#">STRING</a>
	unit:	-
	default value:	-
	limitations:	existing mark

**Subcommand**

**type:** subcommand

**Function:** to be used for setting the pre-defined displacements of the supports

**Parameters:**

**MODE** - identification name of the piping system operating mode.

type:	<a href="#">TEXT</a>
unit:	-
default value:	-
limitations:	see limitations for the text values of parameters. The operating mode shall preliminarily be described by the <a href="#">OPVAL</a> command

**DX** support displacement along the global X axis

type:	<a href="#">REAL</a>
unit:	mm
default value:	0
limitations:	-

**DY** support displacement along the global Y axis

type:	<a href="#">REAL</a>
unit:	mm
default value:	0
limitations:	-

**DZ** support displacement along the global Z axis

type:	<a href="#">REAL</a>
unit:	mm
default value:	0
limitations:	-

**Note:**

- 1) The "rod hanger" element is a one-way link limiting movements of the piping system vertically downwards.
- 2) The *GROUP* and *CNODE* parameters are mutually exclusive;
- 3) *CNODE* can be used to tie one node in the piping system to any other node in the system. If *CNODE* is set no restraint's movement could be defined;
- 4) With the parameter value of *OUT* = 'YES', a file with the name of "SPRH\_001\_100.dat" type will appear in the working directory of the model after execution of the analysis. In the file name: "100" is the node name, "001" -is the sequence number of the one-component support located in the "100" node. The file contains 7 columns of numbers: first column - time, 2nd - 4th columns - components of forces in the support (*F<sub>x</sub>*, *F<sub>y</sub>*, *F<sub>z</sub>*); 5th - 7th columns - dynamic deformations of the support (*D<sub>x</sub>*, *D<sub>y</sub>*, *D<sub>z</sub>*).

Example :

2000: ROD NC 2 LEN 1000. NOTE "12RABQ005"

## Viscous Damper (DMP)

The screenshot shows a dialog box titled "Damper" with a close button (X) in the top right corner. The dialog has three tabs: "General", "Movements", and "Supporting Structure". The "General" tab is selected. The dialog contains the following controls:

- Input field for  $K_x$  with the value  $1.56e4$ .
- Input field for  $K_y$  with the value  $2.35e4$ .
- Input field for  $K_z$  with the value  $1e+009$ .
- Checkbox labeled "Default" below  $K_x$  (unchecked).
- Checkbox labeled "Default" below  $K_y$  (unchecked).
- Checkbox labeled "Default" below  $K_z$  (checked).
- Input field for  $F_i^\circ$  with the value  $0$ .
- At the bottom left, a checkbox labeled "Deactivate" (unchecked).
- At the bottom center, an "OK" button.
- At the bottom right, "Cancel" and "Help" buttons.

**type:** local geometrical command

**Function:** modeling of the viscous damper (viscoelastic damper or High Viscous Damper);

### Parameters:

<b>NAME</b>	damper name
type:	<a href="#">TEXT</a>
unit:	-
default value:	<a href="#">blank</a>
limitations:	(1)

<b>TYPE</b>	damper model
	type: <a href="#">TEXT</a>
	unit: -
	default value: 'VED'
	limitations: 'VED', 'VIS', 'MXW'
<b>TD<sup>2)</sup></b>	temperature of the damper's working fluid
	type: <a href="#">REAL</a>
	unit: °C
	default value: 20
	limitations: from -10°C to +100°C , (2)
<b>LH</b>	nominal load in the horizontal direction
	type: <a href="#">REAL</a>
	unit: Newton
	default value: 0
	limitations: ≥ 0
<b>LV</b>	nominal load in the vertical direction
	type: <a href="#">REAL</a>
	unit: N
	default value: 0
	limitations: ≥ 0
<b>DH</b>	permissible movements in the horizontal direction
	type: <a href="#">REAL</a>
	unit: mm
	default value: 0
	limitations: ≥ 0
<b>DV</b>	permissible movements in the vertical direction
	type: <a href="#">REAL</a>
	unit: mm
	default value: 0
	limitations: ≥ 0
<b>FH</b>	characteristic frequency in the horizontal direction
	type: <a href="#">REAL</a>
	unit: Hz
	default value: 0
	limitations: ≥ 0

**FV** characteristic frequency in the horizontal direction

type: [REAL](#)  
unit: Hz  
default value: 0  
limitations:  $\geq 0$

**CH** stiffness in the horizontal direction

type: [REAL](#)  
unit: N/mm  
default value: 0  
limitations:  $\geq 0$

**CV** stiffness in the vertical direction

type: [REAL](#)  
unit: N/mm  
default value: 0  
limitations:  $\geq 0$

**VH** viscosity in the horizontal direction

type: [REAL](#)  
unit: N\*s/mm  
default value: 0  
limitations:  $\geq 0$

**VV** viscosity in the vertical direction

type: [REAL](#)  
unit: N\*s/mm  
default value: 0  
limitations:  $\geq 0$

**K1\_H, C1\_H, K2\_H, C2\_H** coefficients of the 4-parameter Maxwell model of the damper for the horizontal direction

type: [REAL](#)  
unit: (K1\_H, K2\_H: N/mm, C1\_H, C2\_H: rad/s)  
default value: 0  
limitations:  $\geq 0$

**K1\_V, C1\_V, K2\_V, C2\_V** coefficients of the 4-parameter Maxwell model of the damper for the vertical direction.

type: [REAL](#)  
unit: (K1\_V, K2\_V: N/mm, C1\_V, C2\_V: rad/s)

default value: 0  
 limitations:  $\geq 0$

**GROUP**

name of the seismic group of supports

type: [TEXT](#)  
 unit: -  
 default value: name of the first group of spectrums described by the [SPEC](#) command  
 limitations: name of the group to be selected from the 'GROUP' parameter of the [SPEC](#) command

**OUT<sup>3)</sup>**

write the "time - force - deformation" records in a text file (available only for THA: [DYN](#)='THA')

type: [TEXT](#)  
 unit: -  
 default value: 'NO'  
 limitations: 'YES' or 'NO'

**NOTE<sup>4)</sup>**

support ID

type: [STRING](#)  
 unit: -  
 default value: [blank](#)  
 limitations: see limitations for the string values of parameters, the length shall not be more than 32 characters

**CNODE<sup>4,5)</sup>**

connecting node

type: [TEXT](#)  
 unit: -  
 default value: -  
 limitations: the parameter shall refer to the label of one of the existing nodes of the analytical model

**KX, KY, KZ** stiffnesses of the civil supporting structures

type: [REAL](#)  
 unit: N/mm  
 default value: [rigid](#)  
 limitations:  $\geq 0$

**FI**

angle of rotation of the global axes of the supporting structure about Z axis (similar to DS(1) angle for [spherical coordinate system](#))

type: [REAL](#)  
 unit: degrees  
 default value: 0  
 limitations:  $\geq 0$

**Subcommand**

**type:** subcommand

**Function:** to be used for setting the pre-defined displacements of the supports

**Parameters:**

**MODE** - identification name of the piping system operating mode.

type:	<a href="#">TEXT</a>
unit:	-
default value:	-
limitations:	see limitations for the text values of parameters. The operating mode shall preliminarily be described by the <a href="#">OPVAL</a> command

**DX** support displacement along the global X axis

type:	<a href="#">REAL</a>
unit:	mm
default value:	0
limitations:	-

**DY** support displacement along the global Y axis

type:	<a href="#">REAL</a>
unit:	mm
default value:	0
limitations:	-

**DZ** support displacement along the global Z axis

type:	<a href="#">REAL</a>
unit:	mm
default value:	0
limitations:	-

**Note:**

- 1) *Dampers are active only within dynamic analysis. The program provides 2 types of damper's characteristics: in explicit and implicit forms (see the table below). In case when the damper is set in the implicit form, the program will automatically determine the damper support characteristics using the data containing in the 'DMP.DBS' file. In doing so, the damper name (NAME parameter) shall exactly correspond to one of the standard names given in this file. The nomenclature and parameters of the dampers of VD type are given in [Appendix III](#).*

**Different variants for modeling the viscous damper**

Model	Parameters used		Type of Analysis
	explicit mode	implicit mode	
elastic (TYPE = 'VED')	TYPE, LH, LV, DH, DV, CH, CV, GROUP, NOTE	NAME, TYPE, TD, FH, FV, GROUP, NOTE	RSM, THA
ideal viscous (TYPE = 'VIS')	TYPE, LH, LV, DH, DV,	NAME, TYPE, TD, FH, FV, NOTE	THA

	VH, VV, GROUP, NOTE		
Maxwell (TYPE = 'MXW')	TYPE, LH, LV, DH, DV, K1_H, C1_H, K2_H, C2_H, K1_V, C1_V, K2_V, C2_V	NAME, TYPE, TD, NOTE	THA

- 2) The TD parameter shall be used only for dampers filled with silicone gel fluid (for example, dampers of VD series). In case when the temperature of the damper fluid is within the range from -10 ° C to +100 ° C, the dynamic characteristics of the damper shall be corrected by means of the following empirical expression:

$$Si_t = 1.47 \cdot Si_{20} \cdot e^{-0.0193 \cdot t}, \text{ where}$$

$Si_t$  - stiffness parameter at the working temperature  $t$ ;

$Si_{20}$  - stiffness parameter at the temperature of +20 ° C (the damper model characteristics of VD type are set in the database namely for this temperature);

$t$  - working temperature of the fluid in the damper (in degrees).

In order to determine the working temperature in the damper fluid, it is recommended to use the following empirical relation:

$$t = k \cdot (t_m - t_s) + t_s, \text{ where:}$$

$t$  - working temperature of the fluid in the damper;

$t_m$  - operating temperature of the piping content;

$t_s$  - ambient temperature in the compartment;

$k$  - heat transfer coefficient to be taken depending upon the connection between the damper piston and the piping. In case of direct connection,  $k=0.136$ ; in case of connection via a heat-insulating gasket,  $k=0.1$ ; in case of connection via spacer made from hollow profile,  $k=0.071$ .

- 3) With the parameter value of OUT = 'YES', a file with the name of "DAMP\_001\_100.dat" type will appear in the working directory of the model after execution of the analysis. In the file name: "100" is the node name, "001" -is the sequence number of the one-component support located in the "100" node. The file contains 7 columns of numbers: first column - time, 2nd - 4th columns - components of forces in the damper ( $F_x$ ,  $F_y$ ,  $F_z$ ); 5th - 7th columns - dynamic deformations of the support ( $D_x$ ,  $D_y$ ,  $D_z$ ). The OUT parameter is used only for the viscous or Maxwell model of the damper (TYPE = 'VIS' or 'MXW').
- 4) The GROUP and CNODE parameters are mutually exclusive;
- 5) CNODE can be used to tie one node in the piping system to any other node in the system. If CNODE is set no restraint's movement could be defined.

Examples:

```
2000: DMP TYPE = 'MXW' 'VD-426/219-3' TD 50
2000: DMP TYPE = 'VED' 'VD-426/219-3' TD 50 FH 5 FV 7
```

## Snubber (SNUB)

The screenshot shows the 'Snubber' dialog box with the following parameters and options:

- Node:** 20
- Catalog:** LISEGA
- ID:** 308216
- Database:** Database...
- Stiffness (STF):** 116667,  Default
- Length (LEN):** 730,  Default
- Travel (TRAVEL):** 150
- Angle (ANGLE):** 6
- Lost Motion (LM):** 0.5
- Max. Load (FL):** 472000
- Direction (DC/DS/DIRL):**
  - Coordinate System:  3D,  A,  H,  N
  - Local:
  - dA:  dH:  dN:
- Offset of the element attachment point to the pipeline (OFFS):**
  - dA:  dH:  dN:
- GROUP/CNODE:**
  - Reference Element:
  - Seismic Group/Connection Node:
    - Node
    - Group
    - Connection Node:
- OUT:**  Output THA Results
- Designation:**
- Comment:**

Buttons at the bottom:  Deactivate, , ,

**type:** local geometrical command

**Function:** mechanical or hydraulic snubber

**Parameters:**

**TYPE<sup>1)</sup>** type of snubber's model

type: [TEXT](#)  
unit: -  
default value: 'LIN'

	limitations:	'LIN', 'MCH', 'HDR'
<b>TBL</b>	identification name of the table with snubber's characteristics	
	type:	<a href="#">TEXT</a>
	unit:	-
	default value:	-
	limitations:	определяется командами \$TITLE в заголовках таблиц амортизаторов (файл SNUB.DBS)
<b>ID</b>	snubber identifier	
	type:	<a href="#">TEXT</a>
	unit:	-
	default value:	-
	limitations:	determined by \$TITLE commands in the headers of snubber's tables (file SNUB.DBS)
<b>STF</b>	snubber spring rate	
	type:	<a href="#">REAL</a>
	unit:	N/mm
	default value:	<a href="#">rigid</a>
	limitations:	$\geq 0$
<b>TRVL</b>	snubber's travel: defines permissible movement of the snubber's piston	
	type:	<a href="#">REAL</a>
	unit:	mm
	default value:	0
	limitations:	$\geq 0$
<b>LEN</b>	distance between the two hinges: the attachment points of the snubber to the pipe clamp and to the support structure	
	type:	<a href="#">REAL</a>
	unit:	mm
	default value:	0
	limitations:	$\geq 0$
<b>ANGLE</b>	permissible rotation angle of the snubber relative to the attachment point. Calculated if the LEN value is specified.	
	type:	<a href="#">REAL</a>
	unit:	degrees Celsius
	default value:	0
	limitations:	$\geq 0$
<b>LM</b>	piston rod play (lost motion): when the displacements of the snubber's attachment point to the pipe are less than the LM value, the snubber does not operate	
	type:	<a href="#">REAL</a>
	unit:	mm
	default value:	0
	limitations:	$\geq 0$

<b>OFFS(3)</b>	offset of the snubber's attachment point to the axis of pipe. Specified in the local coordinates of the pipe.										
	<table border="0"> <tr> <td>type:</td> <td><a href="#">REAL(3)</a></td> </tr> <tr> <td>unit:</td> <td>mm</td> </tr> <tr> <td>default value:</td> <td>array of three numbers</td> </tr> <tr> <td>limitations:</td> <td>0, 0, 0</td> </tr> <tr> <td>область возможных значений:</td> <td>-</td> </tr> </table>	type:	<a href="#">REAL(3)</a>	unit:	mm	default value:	array of three numbers	limitations:	0, 0, 0	область возможных значений:	-
type:	<a href="#">REAL(3)</a>										
unit:	mm										
default value:	array of three numbers										
limitations:	0, 0, 0										
область возможных значений:	-										
<b>DC or DS:</b>	direction of the action of snubber; see <a href="#">"Local commands" section</a> for the description of parameters.										
<b>DIRL<sup>2)</sup>:</b>	alternative form of setting the direction of the snubber action line										
	<table border="0"> <tr> <td>type:</td> <td><a href="#">TEXT</a></td> </tr> <tr> <td>unit:</td> <td>-</td> </tr> <tr> <td>default value:</td> <td>-</td> </tr> <tr> <td>limitations:</td> <td>'H', 'N', 'A'</td> </tr> </table>	type:	<a href="#">TEXT</a>	unit:	-	default value:	-	limitations:	'H', 'N', 'A'		
type:	<a href="#">TEXT</a>										
unit:	-										
default value:	-										
limitations:	'H', 'N', 'A'										
<b>GAP</b>	gap (available only for mechanical snubber model within THA)										
	<table border="0"> <tr> <td>type:</td> <td><a href="#">REAL</a></td> </tr> <tr> <td>unit:</td> <td>mm</td> </tr> <tr> <td>default value:</td> <td>0</td> </tr> <tr> <td>limitations:</td> <td>≥ 0</td> </tr> </table>	type:	<a href="#">REAL</a>	unit:	mm	default value:	0	limitations:	≥ 0		
type:	<a href="#">REAL</a>										
unit:	mm										
default value:	0										
limitations:	≥ 0										
<b>V0</b>	threshold rate of locking of the hydraulic snubber (only for THA)										
	<table border="0"> <tr> <td>type:</td> <td><a href="#">REAL</a></td> </tr> <tr> <td>unit:</td> <td>mm/s</td> </tr> <tr> <td>default value:</td> <td>0</td> </tr> <tr> <td>limitations:</td> <td>≥ 0</td> </tr> </table>	type:	<a href="#">REAL</a>	unit:	mm/s	default value:	0	limitations:	≥ 0		
type:	<a href="#">REAL</a>										
unit:	mm/s										
default value:	0										
limitations:	≥ 0										
<b>B0</b>	initial damping in the hydraulic snubber										
	<table border="0"> <tr> <td>type:</td> <td><a href="#">REAL</a></td> </tr> <tr> <td>unit:</td> <td>N*s/mm</td> </tr> <tr> <td>default value:</td> <td>0</td> </tr> <tr> <td>limitations:</td> <td>≥ 0</td> </tr> </table>	type:	<a href="#">REAL</a>	unit:	N*s/mm	default value:	0	limitations:	≥ 0		
type:	<a href="#">REAL</a>										
unit:	N*s/mm										
default value:	0										
limitations:	≥ 0										
<b>FL</b>	maximum load capacity										
	<table border="0"> <tr> <td>type:</td> <td><a href="#">REAL</a></td> </tr> <tr> <td>unit:</td> <td>N</td> </tr> <tr> <td>default value:</td> <td>0</td> </tr> <tr> <td>limitations:</td> <td>≥ 0</td> </tr> </table>	type:	<a href="#">REAL</a>	unit:	N	default value:	0	limitations:	≥ 0		
type:	<a href="#">REAL</a>										
unit:	N										
default value:	0										
limitations:	≥ 0										
<b>GROUP</b>	name of the seismic group of supports										
	<table border="0"> <tr> <td>type:</td> <td>TEXT</td> </tr> <tr> <td>unit:</td> <td>-</td> </tr> <tr> <td>default value:</td> <td>name of the first group of spectrums described by the <a href="#">SPEC</a> command</td> </tr> </table>	type:	TEXT	unit:	-	default value:	name of the first group of spectrums described by the <a href="#">SPEC</a> command				
type:	TEXT										
unit:	-										
default value:	name of the first group of spectrums described by the <a href="#">SPEC</a> command										

	limitations:	name of the group to be selected from the 'GROUP' parameter of the <a href="#">SPEC</a> command
<b>OUT</b> <sup>3)</sup>		write the "time - force - deformation" records in a text file (available only for THA: <a href="#">DYN</a> ='THA')
	type:	<a href="#">TEXT</a>
	unit:	-
	default value:	'NO'
	limitations:	'YES' or 'NO'
<b>NOTE</b> <sup>4)</sup>		support ID
	type:	<a href="#">STRING</a>
	unit:	-
	default value:	<a href="#">blank</a>
	limitations:	see limitations for the string values of parameters, the length shall not be more than 32 characters
<b>CNODE</b> <sup>4,5)</sup>		connecting node
	type:	<a href="#">TEXT</a>
	unit:	-
	default value:	-
	limitations:	the parameter shall refer to the label of one of the existing nodes of the analytical model
<b>DBS_TBL</b>		reference to the table in <a href="#">DB for supports</a>
	type:	<a href="#">STRING</a>
	unit:	-
	default value:	-
	limitations:	existing table in DB
<b>DBS_REF</b>		reference to the record from the DBS_TBL table
	type:	<a href="#">STRING</a>
	unit:	-
	default value:	-
	limitations:	existing record

### Subcommand

**type:** subcommand

**Function:** to be used for setting the pre-defined displacements of the supports

### Parameters:

**MODE** - identification name of the piping system operating mode.

type: [TEXT](#)

unit: -  
default value: -  
limitations: see limitations for the text values of parameters. The operating mode shall preliminarily be described by the [OPVAL](#) command

**DX** support displacement along the global X axis

type: [REAL](#)  
unit: mm  
default value: 0  
limitations: -

**DY** support displacement along the global Y axis

type: [REAL](#)  
unit: mm  
default value: 0  
limitations: -

**DZ** support displacement along the global Z axis

type: [REAL](#)  
unit: mm  
default value: 0  
limitations: -

**Note:**

- 1) Hydraulic snubbers described by the *SNUB* command are taken into account in the analysis only within the framework of dynamic analysis. When using the linear response spectrum method, only a linear snubber (*TYPE='LIN'*) is considered. **Data entry for snubbers of type 'MCH' and 'HDR' is available only in text mode.** The figures given below illustrate different snubber models available within *THA*. Depending upon the snubber type, the command can contain the parameters defined in [Table](#)

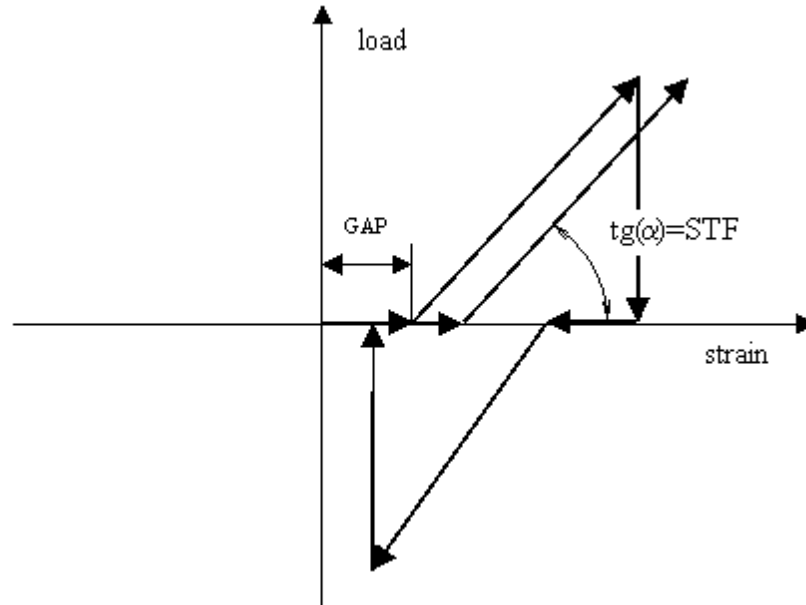

Mechanical snubber model

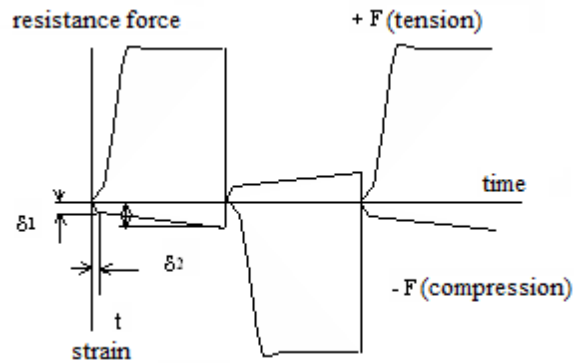

Hydraulic snubber model

### Combination of parameters with various forms of setting the **SNUB** command

Snubber model	Parameters	Type of analysis
Linear (TYPE='LIN')	TYPE, TBL, ID, TRVL, LEN, ANGLE, LM, OFFS, STF, DC (DS), FL, GROUP, NOTE, DBS_TBL, DBS_REF	<a href="#">RSM</a> , <a href="#">THA</a>
Mechanical (TYPE='MCH')	TYPE, STF, DC (DS), GAP, FL, GROUP, NOTE	<a href="#">THA</a>
Hydraulic (TYPE='HDR')	TYPE, STF, DC (DS), V0, B0, FL, GROUP, NOTE	<a href="#">THA</a>

- 2) The direction of action of the snubber axis is set either by means of direction cosines (DC or DS) in the global coordinate system of the piping system or in the local axis of the support with respect to the piping system axis (DIRL parameter). In the latter case, DIRL can take the following values: 'H' and 'N' - perpendicularly to the piping system axis, 'A' - along the piping system axis. The rule for local coordinates of the support is given in [Appendix II](#).
- 3) With the parameter value of OUT = 'YES', a file with the name of "SNUB\_001\_100.dat" type will appear in the working directory of the model after execution of the analysis. In the file

name: "100" is the node name, "001" -is the sequence number of the snubber located in the "100" node. The file contains 3 columns of numbers: the first column - time, 2nd column - snubber's reaction, 3rd column - deformation of the snubber.

- 4) The GROUP and CNODE parameters are mutually exclusive;
- 5) CNODE can be used to tie one node in the piping system to any other node in the system. If CNODE is set no restraint's movement could be defined.

Examples :

```
1340: SNUB STF = 110000 FL = 735000 LEN = 620 ANGLE = 6 dc = 'X' note = "10LBA30BQ4119"
1340: SNUB tbl = 'LISEGA' id = '319816' LEN = 620 dc = 'X' note = "10LBA30BQ4119"
```

```
2000: SNUB TYPE 'MCH' DC 1, 0, 0 STF 1.e3 GAP 2. FL 1.4e5
2000: SNUB TYPE 'HDR' DC 1, 0, 0 STF 1.e3 V0 2. B0 600 FL 1.4e5
```

## Dynamic Limit Stop (DGAP)

**The specification of the integration step is required when using Dynamic Limit Stops. It must be determined by the user based on the maximum frequency (minimum period) of the partial subsystem in which this element is installed.**

Type: local geometrical command

**Function:** modeling of limit stop (restraint with gaps) active only within dynamic analysis<sup>1)</sup>

**Parameters:**

<b>ST+</b>	stiffness of the restraint acting after closure of the positive gap
	type: <a href="#">REAL</a>
	unit: N/mm
	default value: 0
	limitations: $\geq 0$
<b>ST-</b>	stiffness of the restraint acting after closure of the negative gap
	type: <a href="#">REAL</a>
	unit: N/mm
	default value: 0
	limitations: $\geq 0$
<b>DS+</b>	positive gap value
	type: <a href="#">REAL</a>
	unit: mm
	default value: 0
	limitations: $\geq 0$
<b>DS-</b>	negative gap value
	type: <a href="#">REAL</a>
	unit: m
	default value: 0
	limitations: $\geq 0$
<b>DIR<sup>2)</sup></b>	projections of the line of action of the element on the global coordinates XYZ, or the corresponding direction cosines.
	type: <a href="#">REAL</a>
	unit: -
	dimension: array of three element
	default value: -
	limitations: all three elements of the array cannot be simultaneously equal to zero
<b>DIRL<sup>2)</sup></b>	alternative form of setting the direction of action of the element (in local coordinates)
	type: <a href="#">TEXT</a>
	unit: -
	default value: -
	limitations: 'A', 'H', 'N'
<b>OUT<sup>3)</sup></b>	flag of output of the time history of forces/deformations for printing
	type: <a href="#">TEXT</a>
	unit: -
	default value: 'NO'

	limitations:	'YES', 'NO'
<b>NOTE</b>	Note / Comment	
	type:	<a href="#">STRING</a>
	unit:	-
	default value:	<a href="#">blank</a>
	limitations:	see limitation for string parameter values

### Subcommand

**type:** subcommand

**Function:** to be used for setting the pre-defined displacements of the supports

### Parameters:

**MODE** - identification name of the piping system operating mode.

	type:	<a href="#">TEXT</a>
	unit:	-
	default value:	-
	limitations:	see limitations for the text values of parameters. The operating mode shall preliminarily be described by the <a href="#">OPVAL</a> command

**DX** support displacement along the global X axis

	type:	<a href="#">REAL</a>
	unit:	mm
	default value:	0
	limitations:	-

**DY** support displacement along the global Y axis

	type:	<a href="#">REAL</a>
	unit:	mm
	default value:	0
	limitations:	-

**DZ** support displacement along the global Z axis

	type:	<a href="#">REAL</a>
	unit:	mm
	default value:	0
	limitations:	-

Note:

- 1) The command is valid only within [THA](#) ([DYN](#)='THA')
- 2) The parameters determining the direction of action of the [DIR](#) and [DIRL](#) elements are mutually exclusive. See [Appendix II](#) for determination of the local coordinate system.
- 3) With the parameter value of [OUT](#) = 'YES', a file with the name of "DGAP\_001\_100.dat" type will appear in the working directory of the model after execution of the analysis. In the file name: "100" is the node name, "001" -is the sequence number of the snubber located in the

"100" node. The file contains 3 columns of numbers: the first column - time, 2nd column - forces in the link, 3rd column - movements in the element.

Example:

```
123: DGAP ST+ = 1.e4 ST- = 1.e4 DS+ = 2 DS- = 2 DURL='H' OUT='YES'
```

## Concentrated Transient Dynamic Load (DFRC)

**Type:** local geometrical command

**Function:** command for applying transient force for THA<sup>1)</sup>

**Parameters:**

**SET** The identification name of the set for dynamics loads' family. SET is referenced in the command **DCASE** (parameter INP)

**FILE**<sup>2,3)</sup> name of the file containing digital records of the applied force

type: [STRING](#)  
 unit: -  
 default value: -

	limitations:	see limitations for string parameter values. The length of string shall not exceed 128 characters.
<b>MULT</b>	scaling factor	
	type:	<a href="#">REAL</a>
	unit:	-
	default value:	1
	limitations:	-
<b>DIR<sup>4)</sup></b>	projections of the line of action of the force on the global coordinates XYZ, or the corresponding direction cosines.	
	type:	<a href="#">REAL</a>
	unit:	-
	dimension:	array of three elements
	default value:	-
	limitations:	all three elements of the array cannot simultaneously be equal to zero.
<b>DIRL<sup>4)</sup></b>	alternative form of setting the direction of action of the concentrated dynamic load (in local coordinates)	
	type:	<a href="#">TEXT</a>
	unit:	-
	default value:	-
	limitations:	'A', 'H', 'N'
<b>NOTE</b>	Note / Comment	
	type:	<a href="#">STRING</a>
	unit:	-
	default value:	<a href="#">blank</a>
	limitations:	see limitations for string parameter values

**Note:**

- 1) *The command is valid only within [THA](#) (DYN='THA')*
- 2) *If the file with digital dynamic force values is located in the current directory of the model, it is sufficient to indicate only its name with the extension. In other cases, it is necessary to indicate the full path to the file.*
- 3) *The file containing the digital values of the force is an ASCII file containing 2 columns of numbers: "time-force" typed in free format. The force shall be set in Newtons. The file must contain a point for the "zero" time moment. If the total time of dynamic action, TT, is greater than the force action time specified in the file, it is assumed that the after that an action of force has stopped (=0).*
- 4) *The parameters determining the directions of action of the force, DIR and DIRL, are mutually exclusive. See [Appendix II](#) for determination of the local coordinate system.*

**Example:**

```
123: DFRC file = 'f1.dat', dir=1,0,0 note = 'Force from operation of the safety val
```

or:

```
123: DFRC file = 'f1.dat', dirl='H' note = 'Force from operation of the safety val
```

## Time History output /Travel indicator (TH\_OUT)

**Type:** local geometrical command

**Function:** output of Time History response parameters

**Parameters:**

**TYPE** type of output parameter

type: [TEXT](#)  
 unit: -  
 default value: 'DSP'  
 limitations: 'DSP', 'VEL', 'ACC', 'FRC'

**NOTE** Note / Comment

type: [STRING](#)  
 unit: -  
 default value: [blank](#)  
 limitations: see limitations for string parameters values

**Note:**

- 1) Within [THA](#) ([DYN](#)=[THA](#)), depending upon the value indicated in the [TYPE](#) parameter, the following relations will be output in the course of post-processing of the results:

TYPE	Parameter	Name of file	Note
DSP	displacements	DSP_NODE.dat	(a)
VEL	velocities	VEL_NODE.dat	
ACC	accelerations	ACC_NODE.dat	
FRC	internal forces/deformations in the element	TYPE_NODE1_NODE2.dat	(b)
STRS	dynamic stresses S2 category (only for CODE = 'PNAE')	TYPE_STRS_NODE1-NODE2.dat	(c)

(a) four columns are output into the file: time + 3 components along the global axes X, Y, Z

(b) depending upon the element type, the "time - components" columns are output into the file (in the local coordinate system)":

Type of element	Beginning of the file name	Components being output
Bend	BEND...	19 columns: time + 3*6 components of the internal forces at the beginning, at the end and in the middle of the element
Straight Pipe	PIPE...	
Reducer	REDU...	13 columns: time + 2*6 components of the internal forces at the beginning and at the end of the element
Expansion Joint	EJ...	19 columns: time + 2*6 forces at the beginning and at the end of the element + 6 deformations in the center of the element
Rigid Link	RIGD...	13 columns: time + 2*6 components of the internal forces at the beginning and at the end of the element
Beam	BEAM...	
Flexible Joint	FLEX..	
Valve	VALV...	

(c) four number columns are writing in the file: time – stress at the beginning of the element, in the middle and at the end

- 2) The command TH\_OUT with DISP parameter (node: TH\_OUT = 'DSP') is considered also as a "travel indicator" and results to a summary table of displacements associated with indicated node for all static Load Sets required displacement output. In viewing the results in the PIPE3DV program, the travel indicators are displayed in the form of three orthogonal arrows:

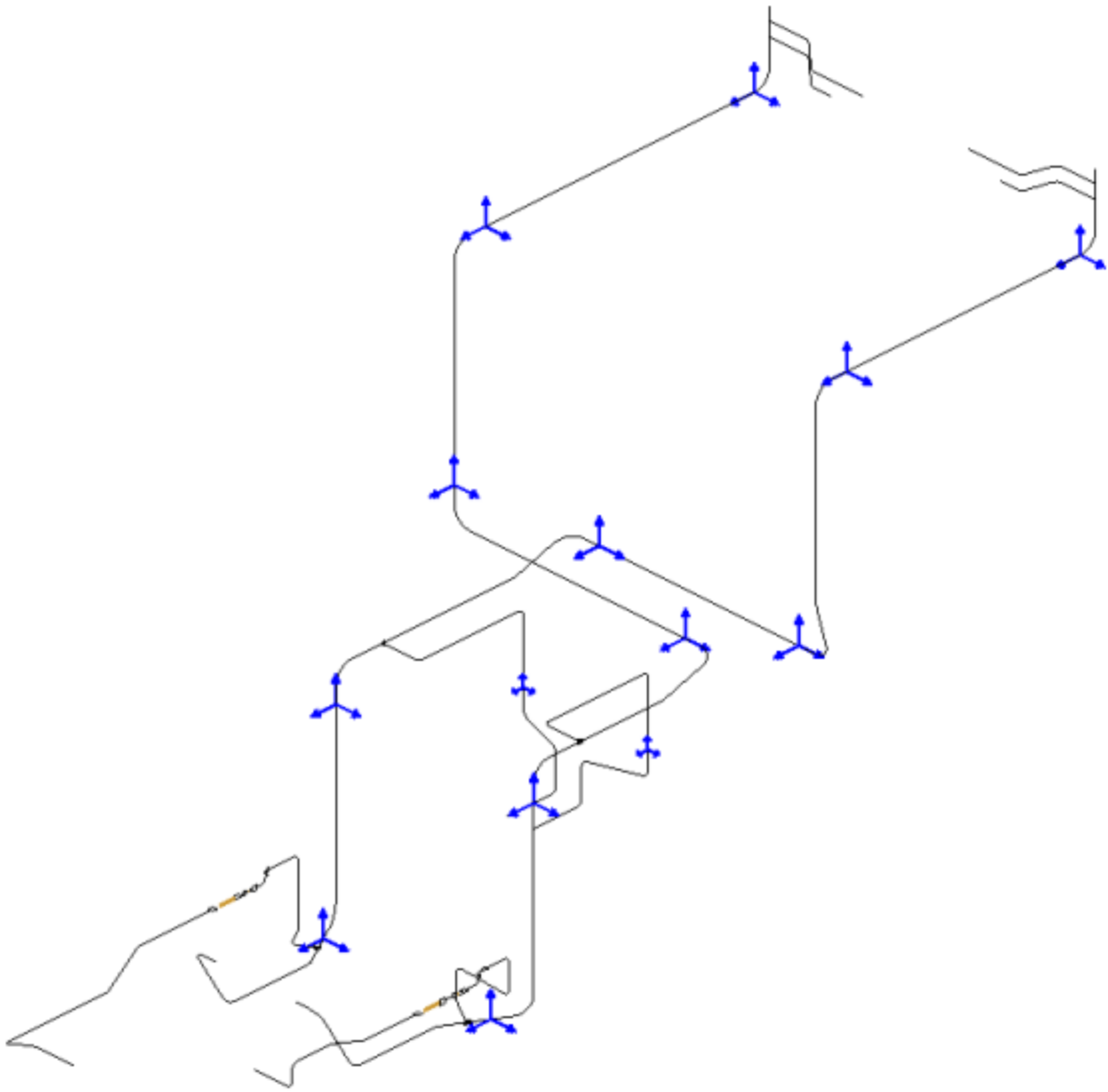

and the following generalized table will be printed in the <model name>.sup file:

>>> Piping movements (displacement monitoring).

```
=====
Point N      DX      DY      DZ      RX      RY
RZ      Mode
  (node)                ( mm )                ( rad )
=====
N# 1          0      -1      -1     -2.109E-04  -3.839E-04
7.167E-05 Weight Deflections
          -15       3       10     1.791E-03  -8.742E-04
9.215E-04 Thermal Expansions
=====
```

3) The command TH\_OUT with ACC parameter (node: TH\_OUT = 'ACC') leads to the summary table with maximal accelerations in the specified node:

```
>>> Accelerartions (g)
=====
      Node      AX      AY      AZ      AV204-1A
=====
      3          2.63    2.38    1.48
      10         -9.76    2.33    4.24    VZ04-1A
      13          6.66    2.32   -2.97    V204-2A
=====
```

Example:

```
123: TH_OUT TYPE = 'ACC'
```

or

```
30: TH_OUT type = 'DSP', note = "N 01"
```

## Discontinuity stresses (STR\_DISC)

**type:** local geometrical multi-line command

**Function:** Input data for assessment of Stress Intensity Range due to structural or material discontinuity. The stresses are used in the analysis according to the "nuclear" codes: PNAE: stress  $(s)_{T0}$  (Appendix 5, Item 2.3.2.4, [REF 1]) and ASME BPVC NB-3653.2, [REF 3].

**Subcommand**

**Parameters:**

<b>MODE</b>	identification name of the operating mode consistent with input parameters.
	type: <a href="#">TEXT</a> unit: - default value: - limitations: see limitations for the text values of parameters. The operating mode shall preliminarily be described by the <a href="#">OPVAL</a> command
<b>TA, TB</b>	range of average temperature on side a(b) of gross structural discontinuity or material discontinuity
	type: <a href="#">REAL</a> unit: °C default value: - limitations: -
<b>EAB</b>	average modulus of elasticity of the two sides of a gross structural discontinuity or material discontinuity at room temperature ( $E_{ab} = 0.5 \cdot (E_a + E_b)$ )
	type: <a href="#">REAL</a> unit: MPa default value: to be determined by the program automatically from the input data limitations: $\geq 0$
<b>AA, AB</b>	coefficient of thermal expansion on side a(b) of a gross structural discontinuity or material discontinuity, at room temperature
	type: <a href="#">REAL</a> unit: $1/^\circ\text{C}$ default value: to be determined by the program automatically from the input data limitations: $\geq 0$
<b>STRESS</b>	pre-computed discontinuity stress value
	type: <a href="#">REAL</a> unit: MPa default value: 0 limitations: -

**Note:** *in one command, it is permitted to set either TA, TB, EAB, AA, AB parameters or STRESS. If no specific reference for operational mode is defined, it's assumed that temperature stresses due to gross structural discontinuity occur for any piping transient from one operational state to another. In this case stresses are calculated automatically. Average temperatures Ta and Tb are taken according to the properties of adjacent parts for given mode.*

Example:

```
2000: STR_DISC
& MODE 'NOL' TA 23 TB 45
```

& MODE 'MODE1' STRESS 345.5

## 9 References

- REF 1. PNAE G-7-002-86 Equipment and pipelines strength analysis codes for nuclear power plants
- REF 2. RD 10-249-98 Strength Design Code for Stationary Boilers and Steam and Hot Water Pipelines
- REF 3. ASME BPVC, Section III, Subsections NB-3600, NC-3600
- REF 4. Report No. Rep 02-05/04-99, Software package for strength analysis of piping systems under the action of operating and seismic loads. dPIPE 5. Theoretical basics
- REF 5. Piping system strength analysis for nuclear power plants. RTM 108.020.01-75
- REF 6. LISEGA Standard supports 2020 - Catalogue, June 2015
- REF 7. V.A. Nakhalov, R.K. Balashova. Adjustment of the piping system anchorage for thermal power plants, M., Energija, 1975
- REF 8. ASME B31.3-2004, Process Piping, ASME Code for Pressure Piping, B31, an American National Standard
- REF 9. Service properties of boiler materials - Guidelines, Issue No.43 - NPO CKTI, 1981
- REF 10. EN 13480-3 Metallic industrial piping - Part 3: Design and calculation
- REF 11. Document No.SM01-08 Example of fatigue strength analysis and fatigue accumulation coefficient for a test piping system, CKTI-Vibroiseism Ltd., [fatigue\\_sample.pdf](#)
- REF 12. ASME B31.1-2007, Power Piping, ASME Code for Pressure Piping, B31, an American National Standard
- REF 13. S.P. Timoshenko. Mechanics of materials, 1976
- REF 14. NP-068-05, Piping valves for nuclear power plants. General technical requirements
- REF 15. ASME ST-LLC 07-02 SIF and K-factor Alignment Project (R1), Paulin Research Group (PRG), March 27, 2011
- REF 16. RD EO 1.1.2.05.0330-2012. Lifetime Extension Guideline for the strength calculations of piping and equipment of RBMK, VVER and EGP reactor facilities
- REF 17. Normativně Technická Dokumentace Asociace Strojních Inženýrů pro použití na jaderných elektrárnách typu VVER, NTD A.S.I. Sekce III, Příloha A, Hodnocení pevnosti zařízení a potrubí jaderných elektráren typu VVER, 2016
- REF 18. WRC-300 (Welding Research Council). Technical position in industry practice, The Design Process for Small Bore Piping, December 1984
- REF 19. ANSI/ANS-58.2-1988, Design basis for potential of light water NPP against the effects of postulated pipe rupture
- REF 20. NUREG-0800, US NRC Standard Review Plan, Section 3.6.2 "Determination of Rupture Locations and Dynamic Effects associated with the Postulated Rupture of Piping"
- REF 21. OTT 1.5.2.01.999.0157-2013 «Supporting structures for elements of nuclear power plants with water-cooled power reactors. General technical requirements»
- REF 22. Addendum to LISEGA catalogue „Standard Supports 2010" in reference to Russian standard pipe dimensions for nuclear application, Document No.: 902205, Rev. 1
- REF 23. GOST R 59115.3-2021, Justification of Strength of Equipment and Pipelines of Nuclear Power Plants. **Short-term mechanical properties of structural materials**
- REF 24. GOST R 59115.9-2021, Justification of Strength of Equipment and Pipelines of Nuclear Power Plants. **Calculation of strength.**
- REF 25. GOST R 59115.15-2021, Justification of Strength of Equipment and Pipelines of Nuclear Power Plants. **Calculation of strength of typical pipeline units.**
- REF 26. Piping Flexibility and Stress Analysis Software dPIPE 5. Verification Manual, [VR01-07](#)
- REF 27. TU 4192-001-20503039-01. Viscoelastic dampers VD series. Specifications

## 10 Appendix I

**Sign convention and directions of the local coordinates for internal forces in elements**

### I. "Straight pipe", "Beam" elements

1. The local A axis is directed along the element axis from node i to node j.
2. If the local A axis is not parallel to the global Z axis, then the local N axis lies in the "local A – global Z" plane and is directed so that its projection onto the global Z axis is positive. The local H axis is constructed according to the right-hand rule ( $H = N \times A$ )

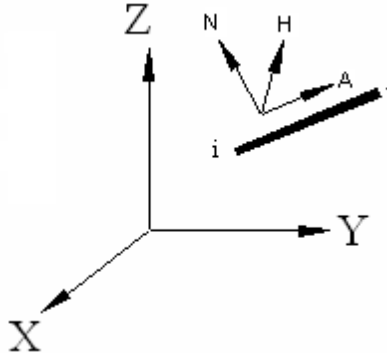

3. If the local A axis is parallel to the global Z axis, then the local H axis coincided with the global Y axis, and the local N axis is constructed according to the right-hand rule ( $N = A \times H$ )

### II. Bend element

1. The local A axis is directed along the tangent to the bend element axis from node i to node j.
2. The local H axis lies in the bend plane perpendicular to the local A axis and is directed from the center of curvature.
3. The local N axis is constructed according to the right-hand rule ( $N = A \times H$ )

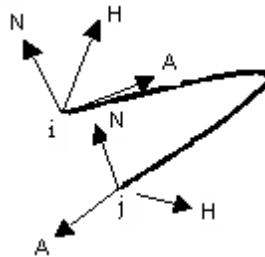

## 11 Appendix II

### Direction of local coordinates for supports

The local coordinate system for supports is determined as follows:

1. The A axis is constructed along the tangent to the axial line of the element from node I to node J.
2. If the element axis is not parallel to the global Z axis, then the H axis is constructed as a perpendicular to the vertical plane being formed by the A and Z axes:  $H = Z \times A$ . If the A axis is parallel to the Z axis, then the H axis coincides with the Y axis.
3. The N axis is constructed perpendicular to the A and H axes:  $N = A \times H$  (see Fig.)

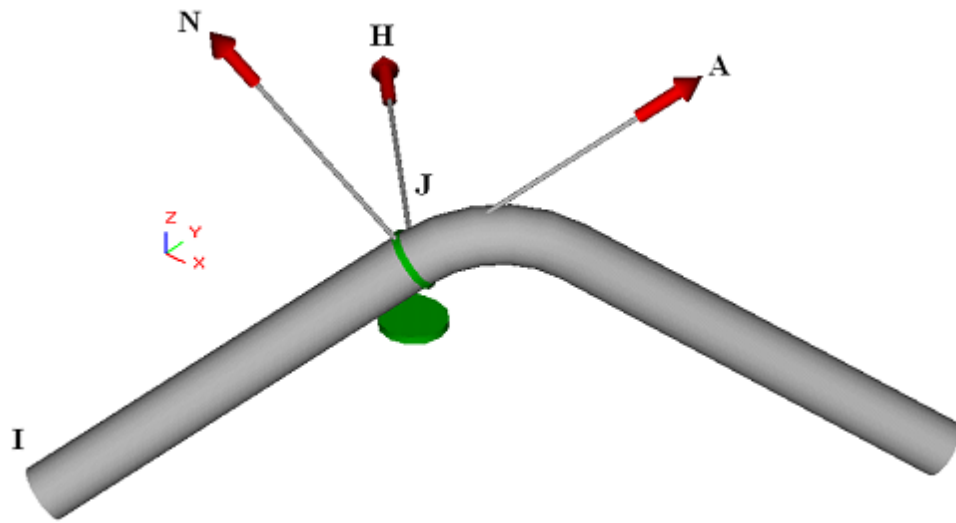

Direction of local coordinates of the support for a non-vertical piping segment

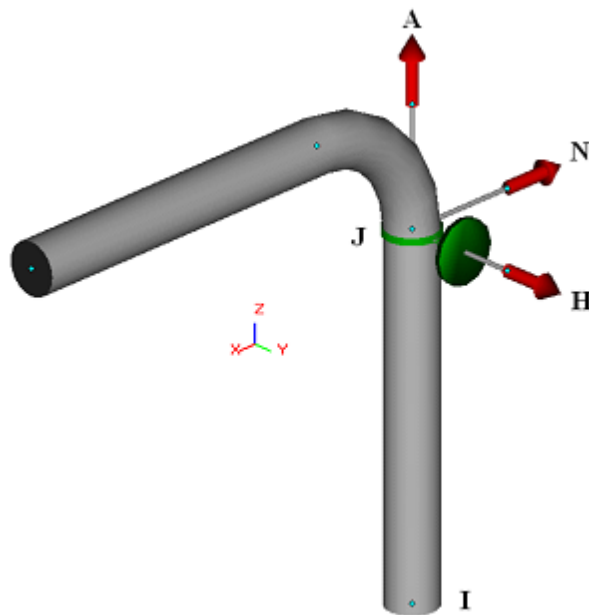

Direction of local coordinates of the support for a vertical piping segment

The characteristics of the *one-component* supports (restraints) can be defined in both the global (XYZ) and the local (AHN) coordinate systems. The last one is defined relative to the adjacent element. In this case, the direction of the support's action should be aligned along the global or local axis. In the \*.dp5 file, these directions correspond to the commands [STX](#), [STY](#), [STZ](#) for the global axis directions, and the commands [STA](#), [STH](#), [STN](#) for the local axis directions, respectively.

**Restraint** [X]

General | Movements | Loads

Node:  **Support in the Global C.S.**

Displacement Type:  Translation  Rotation

Type of Support:  +/-  +  -

Direction

Coordinate System:  3D  X  Y  Z

Global  Local

dX:  dY:  dZ:

Stiffness:  Default

Seismic Group/Connection Node:  Node  Group

Connection Node:

Gap:  Friction:

Output THA Results

Reference:  Designation:

Comment:

Deactivate

In all other cases, it is assumed that the support is defined in an arbitrary direction (command [STS](#)).

In the calculation results, the representation of reaction's components for the one-directional supports (restraints) depends on how they are defined:

Definition along global coordinates: reactions are displayed in the global coordinates system ([STX](#), [STY](#), [STZ](#)).

Definition along local axis of the element ([STA](#), [STH](#), [STN](#)): reactions are displayed in the local coordinates of the element.

Definition in an arbitrary direction ([STS](#)): reactions are displayed in the local coordinates of the support. In this case, the "A" axis is considered as the line of the support's action, and the other axes (H and N) are built according to the rules of the local coordinates for the element (see [Appendix 1](#)).

The label for the support's direction is provided in the results printouts (\*.sup file). This information can also be seen when viewing the results in the PIPE3DV program.

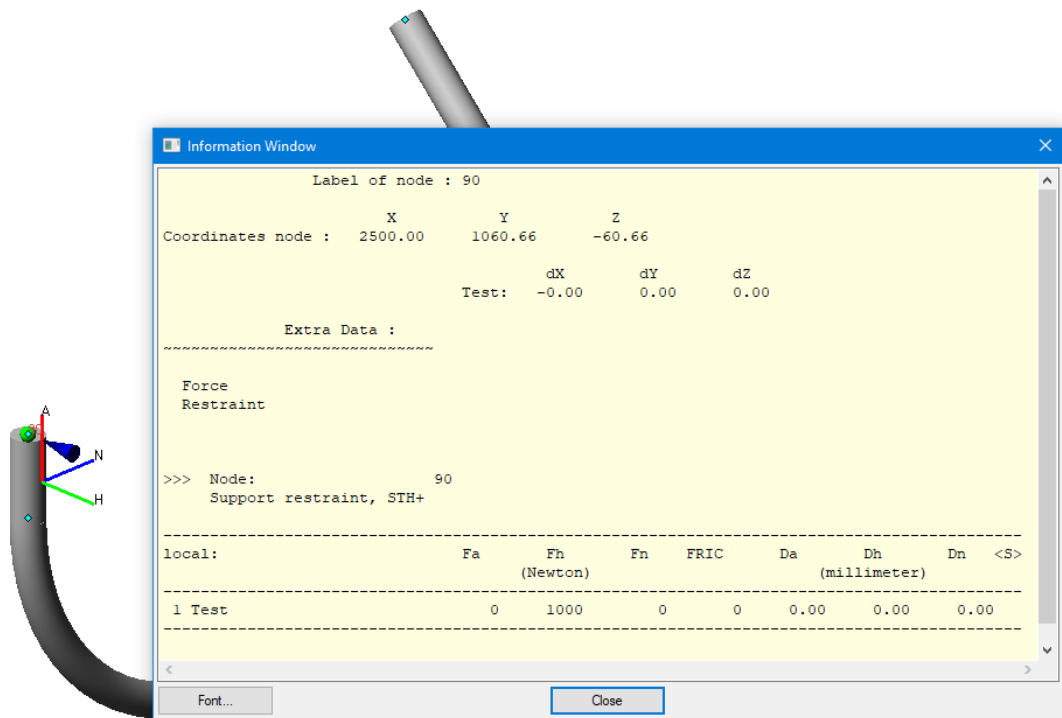

## 12 Appendix III

### Nomenclature and parameters of VD dampers (TU 4192-001-20503039-01)

Damper Type	Nominal Load		Allowable Displacement ( $\pm$ ) From Normal Position		
	Horizontal	Vertical	Horizontal	Vertical	Angular
	H	H	mm	mm	degree
VD-108/57-3	1750	1200	13	13	9
VD-159/76-3	3800	2650	27	25	11
VD-159/76-7	8100	4500	25	25	11
VD-219/108-3	7200	5050	41	24	11
VD-219/108-7	15500	8500	39	24	11
VD-219/159-3	10000	7000	15	24	6
VD-325/159-3	16000	11000	67	40	14
VD-325/159-7	34000	18500	64	40	14
VD-325/159-15	68000	27000	58	40	14
VD-325/219-3	21000	15000	37	40	9
VD-325/219-7	46000	25000	34	40	9
VD-426/219-3	27000	19000	87	45	18
VD-426/219-7	58000	32000	84	45	18
VD-426/219-15	120000	47000	78	45	18
VD-426/325-3	36000	25000	34	45	7

VD-426/325-7	80000	44000	31	45	7
VD-630/325-3	60000	42000	134	74	11
VD-630/325-7	130000	70000	130	74	11
VD-630/325-15	260000	100000	122	74	11
VD-630/426-3	80000	56000	84	74	11
VD-630/426-7	175000	95000	80	74	11
VD-630/426-15	350000	140000	72	74	11

Damper Type	Weight, kg ±5%	Dimensions, mm				
		H*	A	B	d	s
VD 108/57-3	6	152	130	106	14	8
VD 159/76-3	16	197	180	150	18	10
VD 159/76-7	17	197	180	150	18	10
VD 219/108-3	35	236	238	200	22	15
VD 219/108-7	36	236	238	200	22	15
VD 219/159-3	35	236	238	200	22	15
VD 325/159-3	90	333	342	286	33	20
VD 325/159-7	93	333	342	286	33	20
VD 325/159-15	99	333	342	286	33	20
VD 325/219-3	110	333	342	286	33	20
VD 325/219-7	113	333	342	286	33	20
VD 426/219-3	176	378	434	368	39	25
VD 426/219-7	181	378	434	368	39	25
VD 426/219-15	190	378	434	368	39	25
VD 426/325-3	223	378	434	368	39	25
VD 426/325-7	229	378	434	368	39	25
VD 630/325-3	535	556	646	542	60	35
VD 630/325-7	551	556	646	542	60	35
VD 630/325-15	579	556	646	542	60	35
VD 630/426-3	635	556	646	542	60	35
VD 630/426-7	652	556	646	542	60	35
VD 630/426-15	685	556	646	542	60	35

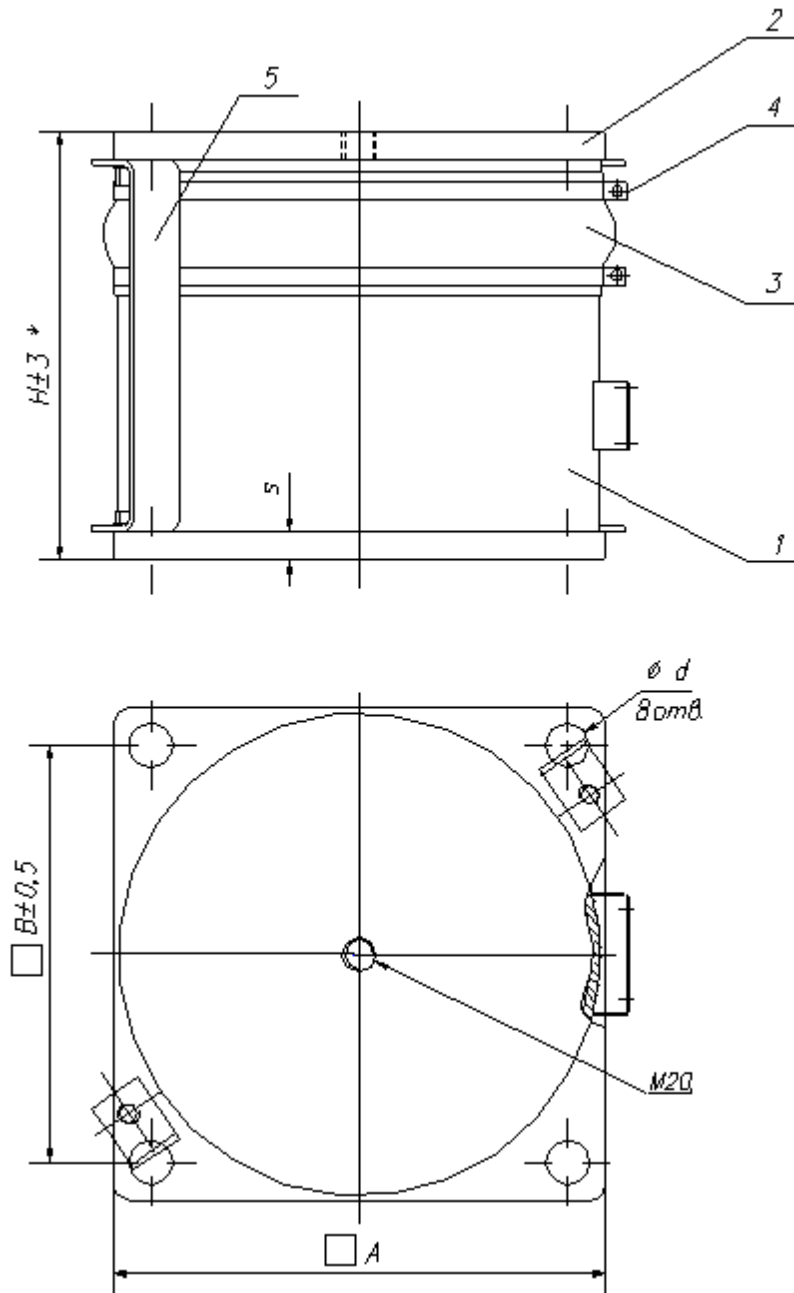

1 – housing; 2 – piston; 3 – protecting sleeve; 4 – hoop; 5 – spacer.

## 13 Appendix IV

### Assignment of the weight characteristics of elements

The weight of any piping component could be considered as sum of three parts:

- $W_1$  – weight of material
- $W_2$  – weight of insulation;
- $W_3$  – weight of piping content.

For elements of "Straight pipe" ([PIPE](#)) and "Bend" ([BEND](#)) the weight characteristics are computed in accordance with the data defined for the corresponding cross-sections ([PIPE](#) command) and information contained in the command for setting the operating modes of the piping system ([OPVAL](#)). For beam elements ([S](#) command) the weight shall be determined in accordance with the  $W$  parameter (weight per length), see [BEAM](#) command.

For piping cross-sections the following parameters shall be set:  $W$  - piping weight per length and  $IWGT$  - insulation weight per length. In addition, for each operating mode the  $CSG$  parameter (Content Specific Gravity), shall be assigned, which is set in fractions of the water weight (for water this parameter is equal to unity:  $CSG = 1$ ). In turn, the density of water is set by the [W\\_DEN](#) parameter ([CTRL](#) command), and the relative density of the piping material - by the  $DEN$  parameter ([MAT](#) command).

Hence the corresponding weight components for each of the "Straight pipe" and "Bend" type element shall be calculated according to the following expressions:

$$\begin{aligned} W_1 &= W * L \\ W_2 &= IWGT * L \\ W_3 &= CSG * W\_DEN * A * L, \end{aligned}$$

where  $A$  is the area of the internal cross-section of the pipe,  $L$  is the element's length.

By default, the  $W$  parameter of piping cross-sections ([PIPE](#) command) is determined according to the formula:

$$W = \pi * (OD - T) * T * DEN * W\_DEN$$

where  $OD$  is the outside diameter of the pipe,  $T$  is the wall thickness.

The total weight load for the element is determined as follows:

$$W_e = W_1 + W_2 + W_3$$

In addition, the concentrated weight characteristics, which can be set by [CW](#) command, shall be added to the above-listed components to the total weight of the piping.

For elements simulating the expansion joints ([EJ](#), [EA](#), [ET](#), [EH](#), [EG](#)), piping valves ([VALV](#), [V1](#), [V2](#)), reducers ([REDU](#)) as well as "rigid" links ([RX](#), [RP](#)), the weight characteristics components are to be set by their parameters. ( $W_1$ ,  $W_2$ ,  $W_3$ ).

In doing so, the following rules are used:

1. If  $W_i > 0$ , then the program will interpret the corresponding value as the component weight (1 – material, 2 – insulation, 3 – content). **For  $W_3$  it is necessary to set the weight of water** (in the course of analysis the program will recalculate this weight depending upon the  $CSG$  value determined for the corresponding operating conditions).
2. If  $W_1 = 0$  and the rest of components are not set, then the total element's weight will be taken equal to zero.
3. If  $W_i < 0$ , then the program will perceive the data as coefficients and use the following formula for determination of the weight load components:

$$W_i = |W_i| * W_{pipe} * L$$

where  $W_{\text{pipe}}$  is the weight per length (material/insulation/water) determined according to the data for the "current" cross-section of the piping system. For reducers ([REDU](#)) the average values of adjacent cross-sections are used.

4. The total weight of the element is determined as the following sum:

$$W_e = W_1 + W_2 + \text{CSG} * W_3$$

5. Depending upon the element type by default the following values of the  $W_1$ ,  $W_2$ ,  $W_3$  parameters are used:

	<a href="#">REDU</a>	<a href="#">VALV</a> , <a href="#">V1</a> , <a href="#">V2</a>	<a href="#">EJ</a> , <a href="#">EA</a> , <a href="#">ET</a> , <a href="#">EH</a> , <a href="#">EG</a>	<a href="#">RX</a> , <a href="#">RP</a>
$W_1$	-1	≠0	0	0
$W_2$	-1	-1.75	0	0
$W_3$	-1	-1	0	0

If the value of parameter  $W_1$  differs from the value specified by default in the table above, then the  $W_2$  and  $W_3$  parameters will take the following values by default:

	<a href="#">REDU</a>	<a href="#">VALV</a> , <a href="#">V1</a> , <a href="#">V2</a>	<a href="#">EJ</a> , <a href="#">EA</a> , <a href="#">ET</a> , <a href="#">EH</a> , <a href="#">EG</a>	<a href="#">RX</a> , <a href="#">RP</a>
$W_1$	0/≠0	0	≠0	≠0
$W_2$	0/-1	0	-1	0
$W_3$	0/-1	0	-1	0

## 14 Appendix V

### Standard sets of Analysis and Postprocessor Specifications

1. [Analysis according to PNAE Codes \[REF 1\]](#)
2. [Analysis according to the RD Boiler Codes \[REF 2\]](#)

### Analysis according to PNAE Code

In case of analysis according to the PNAE Codes, the [CODE](#) parameter can take the values CODE = 'PNAE' for low-temperature piping systems and CODE = 'PNAE\_T' for high-temperature piping calculations.

The full verification analysis according to the PNAE Code assumes performing of the following stages of analysis [\[REF 5\]](#):

Stage	Content of analysis	Load factors taken into account	Purpose	Stress category
I	Analysis for Sustained Loads	Internal pressure (P); weight load (W), spring hangers/supports loads acting in the operating condition (operating load)	Calculation of Primary Stress Intensity	$(\sigma)_2$
II	Analysis for the concurrent action of <u>all</u> loads specified for the operating state	Same as above + thermal expansion (T) + "displacement" loads due to support's movements (D) + cold spring (CS)	Calculation of Support's Reactions and Equipment's Nozzle Loads	(1)
IIIa	Analysis for the effect of the secondary loads (transient of system from one to other load set)	Pressure difference ( $\Delta P$ ); thermal expansion (T); support's displacements (D)	Fatigue strength assessment according to the adaptability criterion	$(\sigma)_{RK}$
III	Analysis of the effect of variable loads with the allowance for stress concentration and additional stress from irregularity of the cross-sectional shape	The same	Satisfaction of Peak Stress Intensity Range, Fatigue strength assessment. Calculation of displacements from thermal expansion.	$(\sigma_{aF})_K$
IV	Analysis for the cold state	Weight load (W); cold spring (CS)	Calculation of Support's Reactions and Equipment's Nozzle Loads	-

**Note:**

(1) For high-temperature piping systems Stage II serves for check of additional conditions for the creep range (assessment of stress of category  $(s)_{RK}$ ). In doing so, the components of the stressed state from the compensation of temperature expansions shall be determined with the account of relaxation due to creep (see the [CREEP](#) command). The main recommended specifications for the execution of analysis according to the PNAE Codes are given in the 'SOLV.DBS' file. At that the following classification of the calculations being performed has been taken:

### LOW-TEMPERATURE PIPING SYSTEMS

#### Calculation No.1 – Spring design + Stress Analysis;

In order to select springs for hanger supports, a set of "starting" computations shall be performed (Load Case):

```
&LC MOD='$OPER' TYPE='DSGN' Note="Spring Hangers Design Load" ; LC1
&LC MOD='$OPER' TYPE='OPER_A' PEND='NO' FRIC='NO' Note="Hot Load.
Selection of springs" ; LC2
&LC MOD='$COLD' TYPE='OPER_B' PEND='NO' FRIC='NO' Note="Cold Load.
Selection of springs" ; LC3
```

In the example above, the first line (LC1) determines "restrained weight" analysis of the system on the rigid supports at the places of installation of spring hangers being selected. In doing so, the "required" values of operating loads in hangers,  $P_h$ , which shall balance the weight load of the piping system. The calculation shall be performed for the operating state; at that the piping system is considered without account of the friction forces in supports and swing effect in hangers.

In case of successful execution of this calculation, it will be followed by the full load analysis (second line, LC2):  $W+P+T+D+P_h$ . It is an analog of Stage II but once again without account of the friction forces and swing effect.

The results of this analysis is determination of the full movement of the system from the "zero" state into the operating state.

The third line of the specification for analysis (LC3) corresponds to the selection of springs with the account of fulfillment of the [PVAR](#) variation condition between the operating (hot) and reference (cold) states. The calculation for spring selection is iterative. The closest springs as to the load are taken as the first approximation for the spring stiffness with the account of the load safety factor [PFAC](#). In addition, the calculation is performed without account of friction and swing effect. On the basis of the results of this calculation the spring type is selected for each spring hanger/support and the value of installation load  $R_0$  is computed.

The successful execution of the "starting" set is followed by the set of main computations:

```
&LC MOD='$OPER' TYPE='OPER_B' PEND='YES' FRIC='YES' Note="Hot Load.
Stage II"; LC4
&LC MOD='$OPER' TYPE='SUST_C' Note="Sustained Loads. Stage I"
; LC5
&LC MOD='$COLD' TYPE='OPER_B' PEND='YES' FRIC = 'YES' Note="Cold Load.
Stage IV"; LC6
```

LC4 – full load calculation (stage II) for the operating state with the account of all support's nonlinearities;

LC5 - analysis for the effect of weight and pressure (stage I). The loads on a hanger and the state of one-way supports perceiving the weight load are determined according to the results of LC4. In doing so, the supports, which "uplifted" at the previous stage of analysis, are excluded. Friction and swing effect are not taken into account.

LC6 – analysis for the reference (cold) state (stage IV) with the account of all support's nonlinearities;

The specification for post-processing of the results of analysis for the example under consideration consists of the following set of commands:

```
&RES='S2_NUE' LS="LC5" Note="S2 stress (NOC)" ; LS1
&RES='SRK' LS="LC4-LC6" Note="Srk Stress"; LS2
&RES='SAF' LS="LC4-LC6" Note="Saf stress" ; LS3
&RES='DISP' LS="LC5" Note ="Weight deflections" ; LS4
&RES='DISP' LS="LC4-LC6" Note ="Thermal expansions" ; LS5
&RES='SUPP' LS="LC4" Note="Hot Loads" ; LS6
&RES='SUPP' LS="LC6" Note="Cold Loads" ; LS7
```

LS1 – determines computations of the stress of category  $(\sigma)_2$  for the combination of loads corresponding to NOC (weight + pressure). For stress computations the internal forces in elements are used, which have been calculated in the LC5 calculation.

LS2 – computation of the stress of category  $(\sigma)_{RK}$  (shakedown condition) as the transient from the cold state into the operating state. In order to determine the stress, the internal forces in elements

are used, which have been calculated as the difference between the loads in the operating and cold states: LC4-LC6.

LS3 – computation of the stress of category  $(\sigma_{aF})_K$  (fatigue strength assessment). The load combination is the same as for stress  $(\sigma)_{RK}$ : LC4-LC6.

LS4, LS5 – printout of the movements from weight loads corresponding to Stage I (LC5) and "visible" movements (differences between the system deformation in the operating state and in the cold state): LC4-LC6.

LS6, LS7 – printout of the loads on supports for the operating (hot) state (LC4) and cold state (LC6).

In case of successful completion of this calculation, a file of <model name>.dp5\_ type will be created in the working directory, which contains data for hangers with the spring types and working loads specified (thereafter this file can be renamed into <model name1>.dp5 and used as the main file for subsequent computations).

### Calculation No.2 – Verification calculation with specified characteristics of spring hangers/supports

In this calculation it is assumed that the spring characteristics and working loads for spring hangers/supports have been determined; therefore, the starting calculations are missing in the specification for analysis. As for the rest, the calculation repeats the previous example:

```
&LC MOD='$OPER' TYPE='OPER_A' PEND='YES' FRIC='YES' Note="Stage II (hot
load)"; LC1
&LC MOD='$OPER' TYPE='SUST_C' Note="Stage I"
; LC2
&LC MOD='$COLD' TYPE='OPER_B' PEND='YES' FRIC = 'YES' Note="Stage IV
(cold load)"; LC3
```

### Calculation No.8 – Verification calculation with determination of the design load on spring hangers/supports

```
&LC MOD='$OPER' TYPE='DSGN' Note="Determination of design load" ; LC1
&LC MOD='$OPER' TYPE='OPER_A' PEND='YES' FRIC='YES' Note="Stage II (hot
load)"; LC2
&LC MOD='$OPER' TYPE='SUST_C' Note="Stage I"
; LC3
&LC MOD='$COLD' TYPE='OPER_B' PEND='YES' FRIC = 'YES' Note="Stage IV
(cold load)"; LC4
```

In this calculation it is assumed that the spring characteristics are known and it is required to determine the working load on hangers. Therefore, the calculation on rigid supports will be performed first (LC1, *TYPE = 'DSGN'*). Then a set of command follows, which is similar to the previous examples.

Any of the calculations listed above can be supplemented by the specification for *analysis under dynamic or seismic load*. For this purpose, the following command shall be added to the specification for analysis:

```
&LC MOD='$OPER' TYPE='MODAL' Note="Modal analysis" ; LC4
```

In accordance with this command, the modal analysis (determination of natural frequencies and mode shapes of the piping system) will be performed. The conditions for the execution of dynamic analysis are set by the [DYN](#), [FMAX](#), [FMESH](#) and [MCOM](#) parameters of the [DCASE](#) and [CTRL](#) commands. The conduction of modal analysis implies a linear system; and, therefore, all piping

system supports are interpreted as two-way ones, and the gaps in supports are not taken into account.

In case when the response spectrum method is used (DYN='RSM'), the seismic load is specified by a set of floor response spectrums ([SPEC](#) command).

According to the results of analysis, the stress of category ( $\sigma$ )<sub>2</sub> is determined for the following combinations of loads NOC + SSE (S2\_MRZ), NOC + OBE (S2\_PZ1) - for piping systems of the first [seismic category](#) and NOC + OBE (S2\_PZ2) – for piping systems of the second [seismic category](#) :

```
&RES='S2_MRZ' LS="LC2 + LC4" Note="S2 stress (SSE)"
&RES='S2_PZ1' LS="LC2 + 0.5*LC4" Note="S2 stress (OBE)"
```

It should be noted that the sequence of location of the reference loads in the parameters for stress computation, S2\_MRZ, S2\_PZ1, S2\_PZ2. is significant, namely: the load calculated for Stage I shall be indicated first (LC2 in this example), and the next load shall be a reference to the modal analysis (LC4). In the example given above, it is assumed that the OBE intensity is equal to a half of SSE; therefore, the factor of 0.5 shall be indicated with the reference to seismic load. In case when the seismic load for OBE and SSE has a different form, it is necessary to perform 2 separate calculations with assignment of their own spectrums for each of the variants.

### Calculation of the "hot" hydraulic test mode

Below the specification for analysis and post-processing of the results is given for the "hot" hydraulic test , which is similar to Stages 5 and 6 in the RAMPA93 software program.

1. By means of the [OPVAL](#) command, set the values of pressure, temperature and weight of working fluid corresponding to the hydraulic test mode:

```
OPVAL 'OPER' ; normal operating conditions
& 'LG1' P= 4.0 T= 350 CSG= 0
OPVAL 'TEST' ; hydraulic test
& 'LG1' P= 5.0, T= 70, CSG= 1 ; csg= 1 -> weight of water is added!
```

2. if necessary, set the values of temperature displacements of fixed supports:

```
10:ANC
& 'OPER' DX= 0 DY= 100 DZ= 0
& 'TEST' DX= 0 DY= 20 DZ= 0
```

3. Add the following commands to the specification for analysis(calculation No.2 should be selected as the basic variant):

Existing commands:

```
SOLV "Verification calculation No.2 + hydraulic test"
&LC MOD='$OPER' TYPE='OPER_A' PEND='YES' FRIC='YES' Note="Stage II"
;LC1
&LC MOD='$OPER' TYPE='SUST_C' Note="Stage I" ;LC2
&LC MOD='$COLD' TYPE='OPER_B' PEND='YES' FRIC='YES' Note="Stage IV"
;LC3
```

Additional commands:

```
&LC MOD='$TEST' TYPE='OPER_B' PEND='YES' FRIC='YES' ; LC4 /P+W+T+D
&LC MOD='$TEST' TYPE='SUST_C' ; LC5 /P+W
```

Existing commands:

POST

```
&RES='S2_NUE' LS="LC2" Note="S2 stress (OPER)"
&RES='SRK' LS="LC1-LC3" Note="SRK stress (COLD->OPER)"
&RES='SAF' LS="LC1-LC3" Note="SAF stress (COLD->OPER)"

&RES='SUPP' LS="LC1" Note="Loads in the operating state"
&RES='SUPP' LS="LC3" Note="Loads in the cold state"

&RES='DISP' LS="LC1" Note="Full movements (OPER)"
&RES='DISP' LS="LC2" Note="Movements from weight (OPER)"
&RES='DISP' LS="LC1-LC3" Note="Visible movements (COLD->OPER)"
```

Additional commands:

```
&RES='S2_HDR' LS="LC5" Note="S2 stress (TEST)"
&RES='SRK' LS="LC4-LC3" Note="SRK stress (COLD->TEST)"
&RES='SAF' LS="LC4-LC3" Note="SAF stress (COLD->TEST)"

&RES='SUPP' LS="LC4" Note="Loads at hydraulic test"

; if movements are required

&RES='DISP' LS="LC4" Note="Full movements (TEST)"
&RES='DISP' LS="LC5" Note="Movements from weight (TEST)"
&RES='DISP' LS="LC4-LC3" Note="Visible movements (COLD->TEST)"
```

**HIGH-TEMPERATURE PIPING SYSTEMS**

The specification for analysis ([SOLV](#) command) for high-temperature piping systems is the same as described above. Below only post-processor commands for stress computation are considered.

Since the creep-rupture strength is used for computing the nominal allowable stress  $[\sigma]$  for high-temperature piping systems ([SR](#) parameter of the [MAT](#) command), it is necessary to check if the corresponding data are present in the properties of material.

The postprocessor command for computation of the  $(\sigma)_2$  stress category is completely similar to low-temperature piping (see above). In computation of allowable stress for operating modes implying short-term loads such as hydraulic tests (S2\_HDR), AOC (S2\_NNUE) as well as seismic loads (S2\_MRZ, S2\_PZ1, S2\_PZ2), it is possible, due to the User's decision, to avoid the account of the creep-rupture strength (see description of the [SN\\_I](#) parameter, [CTRL](#) command).

As the formulae for computation the stress  $(\sigma)_2$  include the strength reduction coefficient for the transverse welded joint  $\phi_w$ , then the results of analysis influence upon the [WLD\\_CHK](#) parameter and the [WLD](#) command.

In order to compute the stress of category  $(\sigma)_{RK}$ , it is necessary to specify the following two post-processor commands:

```
&RES='FORC' LS="LC1-LC2" OUT='NO' Note="Internal forces (Stage 2)" ; LS2
&RES='SRK' LS="LC2+LS2" Note="Srk stress" ; LS3
```

LS2 determines the internal forces from the thermal expansions, which, in accordance with the Codes, can be determined with the account of gradual decrease (relaxation) in time due to creep.

The combination of loads to be specified in LS3 includes the forces as per Stage I (LC2) and the forces computed at the previous stage (LS2). The averaging factor for thermal stresses shall be taken equal to  $0.5 \cdot \chi$  where  $\chi$  is set in input data by means of the [CREEP](#) command. The coefficient  $\chi_{\Theta}$  being contained in the formulae for computation of stress from the ovality of bends shall be determined according to the following formula:

$$\chi_{\Theta} = HI\_E \cdot \chi,$$

where the conversion coefficient [HI\\_E](#) is determined in the [CTRL](#) command.

***The sequence of location of the reference loads in the parameters for computation the SRK stress for high-temperature piping systems shall be the same as given above.***

The stress of category  $(\sigma_{aF})_K$  for high-temperature piping systems is computed similar to low-temperature piping systems:

```
&RES='SAF' LS="LC1-LC3" Note="Saf stress" ; LS3
```

The combination of loads specified above determines the transient from the operating state (LC1, Stage II) into the cold state (LC3, Stage IV).

**Printout of the loads on supports with the account of relaxation and cold springing**

1. The loads on supports with the account of relaxation and cold springing shall be output for anchors and supports.
2. The loads with the account of relaxation of temperature forces shall be computed according to the following formula:

$$LS_{hot} = LC2 + (LC1 - LC2) \cdot (1 - \delta)$$

where

LC2 - loads from weight in the operating state;

LC1 - loads from weight and temperature in the operating state

$\delta$  - thermal stress relaxation coefficient ([DELTA](#) parameter in the [CREEP](#) command)

3. The loads on supports in the cold state with the account of cold springing shall be computed according to the following formula:

$$LS_{cold} = LC3 - (LC1 - LC2) \cdot \delta \cdot (E_{LC3} / E_{LC1})$$

where

LC3 - loads from weight in the cold state;

$(E_{LC3} / E_{LC1})$  - reduction of loads to the cold modulus of elasticity.

In order to implement the above-mentioned formulae, the following commands shall be added to the specification for post-processing with the use of [H\\_REL](#) and [C\\_REL](#) identifiers:

```
&RES='SUPP' LS="LC1-LC2" OUT = 'NO' Note="Loads from temperature"
; LS10
&RES='SUPP' LS="LC2+LS10" RULE = 'H_REL' Note="loads in the operating
state, relaxation" ; LS11
&RES='SUPP' LS="LC3-LS10" RULE = 'C_REL' Note="loads in the cold state,
cold springing" ; LS12
```

## Analysis according to the Russian Boiler Code (RD)

Stress Analysis according to the Russian Boiler Code RD 10-249-98 "Strength Design Code for Stationary Boilers and Steam and Hot Water Pipelines" assumes execution of the similar calculation stages as described above for PNAE Code.

The specifications for different kinds of analyses ([SOLV](#) command) performed according to Boiler Code are the same as for PNAE Code. Differences exist only in for results post-processing in stress calculations :

*Computation of the effective stress at Stage I of the analysis:*

```
&RES='S_I' LS="LC2" Note="S_I stress (Stage 1)" ; LS1
```

As the reference load LC2, the load for Stage I shall be specified.

*Computation of stress at Stage II of the analysis (high-temperature piping systems):*

```
&RES='FORC' LS="LC1-LC2" OUT='NO' Note="Internal forces (Stage 2)" ; LS2
&RES='S_II' LS="LC2+LS2" Note="S_II stress (Stage 2)" ; LS3
```

The specification for *S\_II* stress analysis shall be formed similar to [SRK for high-temperature piping systems according to PNAE](#).

In the example given, the LS2 calculation determines the internal forces from the thermal expansions.

The combination of loads to be specified in LS3 includes the forces as per Stage I (LC2) and forces from the thermal expansions (LS2) computed by the previous command. The averaging coefficient for thermal stresses shall be taken equal to  $0.5 \cdot \chi$  where  $\chi$  is set in input data by means of the [CREEP](#) command.

***The sequence of location of the reference loads in the parameters for computation the *S\_II* stress shall be the same as given above.***

*Computation of the stress at Stage III of the analysis (low-temperature piping systems, fatigue strength assessment):*

```
&RES='S_III' LS="LC1-LC3" Note="S_III stress (Stage 3)" ; LS2
```

The specification for *S\_III* stress analyses shall be formed similar to SAF for PNAE: the transient from the cold state into the operating state is evaluated: LC1 (Stage II) – LC3 (Stage IV).

It should be noted that in accordance with RD (Item 5.2.7, Fig. 5.15) the permissible stress  $[\sigma_a]$  for Stage III depends both upon the type of material (carbon or austenite steels) and from the type of element being evaluated (straight pipe or bend/tee). The data for these stresses shall be given in the FAT command referenced in the [FAT](#) and [FAT\\_B](#) parameters of the [MAT](#) command.

*Determination of the stress at Stage IV of the full analysis (high-temperature piping systems):*

```
&RES='FORC' LS="LC1-LC2" OUT='NO' RULE = 'REF' Note="Internal forces
(Stage 4)" ; LS4
&RES='S_IV' LS="LC3-LS4" Note="S_IV stress (Stage 4)" ; LS5
```

At Stage IV for high-temperature piping systems the check is carried out for the absence of plastic overloads in the cold state. For computation of the *S\_IV* stress, one auxiliary combination of loads

(Line LS4) is required, which determines the difference between the full load (LC1, Stage II) and the load LC2 corresponding to Stage I: LC1 – LC2. The *RULE = 'REF'* parameter is specified for reduction of the combination of internal forces computed to the "cold" (reference) modulus of elasticity. The next line (LS5) determines the calculation of the S\_IV stress on the basis of forces and moments computed as the difference between the forces in the cold state (Stage IV) and the loads computed in LS4 multiplied by the relaxation coefficient  $\delta$  (*DELTA* parameter, *CREEP* command).

**The sequence of location of the reference loads in the parameters for computation of the S\_IV stress shall be the same as given above.**

The recommended sequence of commands for the specification for analysis including the *hydraulic test* mode:

Low-temperature piping systems:

```
SOLV "Verification calculation with specified characteristics of spring
hangers/supports + hydraulic tests"
&LC MOD='$OPER' TYPE='OPER_A' PEND='YES' FRIC='YES' Note="Stage II (full
load)" ; LC1
&LC MOD='$OPER' TYPE='SUST_C' Note="Stage I"
; LC2
&LC MOD='$COLD' TYPE='OPER_B' PEND='YES' FRIC = 'YES' Note="Stage IV
('cold load')"; LC3
&LC MOD='TEST' TYPE='OPER_B' PEND='YES' FRIC = 'YES' Note="Hydraulic
test mode"; LC3 ; LC4
&LC MOD='$OPER' TYPE='SUST_C' Note="Stage I for HT"
; LC5

POST
&RES='S_I' LS="LC2" Note="S_I stress (Stage 1)" ; LS1
&RES='S_III' LS="LC1-LC3" Note="S_III stress (Stage 3)" ; LS2
&RES='S_H' LS="LC5" Note="S_H stress (Stage 1)" ; LS3
&RES='DISP' LS="LC2" Note ="Weight movements" ; LS4
&RES='DISP' LS="LC1-LC3" Note ="Visible movements" ;
LS5
&RES='SUPP' LS="LC1" Note="Loads in the operating state"
; LS6
&RES='SUPP' LS="LC3" Note="Loads in the cold state" ;
LS7
&RES='SUPP' LS="LC4" Note="Loads at HT" ; LS8
```

High-temperature piping systems :

```
SOLV "Verification calculation with specified characteristics of spring
hangers/supports (#2) + hydraulic tests"
&LC MOD='$OPER' TYPE='OPER_A' PEND='YES' FRIC='YES' Note="Stage II (full
load)" ; LC1
&LC MOD='$OPER' TYPE='SUST_C' Note="Stage I"
; LC2
&LC MOD='$COLD' TYPE='OPER_B' PEND='YES' FRIC = 'YES' Note="Stage IV
('cold load')"; LC3
&LC MOD='TEST' TYPE='OPER_B' PEND='YES' FRIC = 'YES' Note="Hydraulic
test mode"; LC3 ; LC4
&LC MOD='$OPER' TYPE='SUST_C' Note="Stage I for HT"
; LC5

POST
&RES='S_I' LS="LC2" Note="S_I stress (Stage 1)" ; LS1
```

```

&RES='FORC' LS="LC1-LC2" OUT='NO' Note="Internal forces (Stage 2)"
; LS2
&RES='S_II' LS="LC2+LS2" Note="S_II stress (Stage 2)" ; LS3
&RES='FORC' LS="LC1-LC2" OUT='NO' RULE = 'REF' Note="Internal forces
(Stage 4)" ; LS4
&RES='S_IV' LS="LC3-LS4" Note="S_IV stress (Stage 4)" ; LS5
&RES='S_H' LS="LC5" Note="S_H stress (Stage 1)" ; LS6
&RES='DISP' LS="LC2" Note = "Weight movements" ; LS7
&RES='DISP' LS="LC1-LC3" Note = "Visible movements" ; LS8
&RES='SUPP' LS="LC1" Note="Loads in the operating state" ;
LS9
&RES='SUPP' LS="LC3" Note="Loads in the cold state" ; LS10
&RES='SUPP' LS="LC4" Note="Loads at HT" ; LS11

```

## 15 Appendix VI

### Appendix VI. Spring hangers design

#### [Basic definitions](#)

#### [Execution of analysis, errors and warnings](#)

#### [Results of analysis](#)

#### [SH.DBS file structure](#)

#### [Selection of springs from LISEGA Catalog](#)

### Basic definitions

**design load ( $P_d$ )** is a target hanger load that should balance weight of the piping. Design load is calculated as reaction of the vertical rigid restraint installed in the location of the designed spring hanger (the stiffness of these restrains is set by [RGD\\_SPR](#) parameter). For this case it is assumed that piping is subjected to sustained loads only (weight of insulated pipe with medium content). Sometimes Design Load is also referred to as Hot Load due to the fact that for most cases a weight balance should be achieved in the operational (hot) state.

**operating or Hot load ( $P_H$ )** – spring hanger/support reaction in Hot state of piping. By value Hot load shall be close to the design load. The difference in the values between these reactions can be caused by the account of nonlinearities (friction forces, one-way supports, swing effect).

**installation (cold) load ( $P_c$ )** – reaction of the spring hanger/support in the cold state (at the installation temperature when piping is empty).

**Hanger Travel ( $u_0$ )** characterizes vertical piping movement that could be measured in the location of spring hanger support between installed (cold) and operating (hot) positions

**theoretical installation load ( $R_0$ )**: physically it's a load that corresponds to the spring preset out of the piping (such procedure is used in Russian practice for "one-stage" spring presetting, see [REF 7](#)). Numerically it can be described as:  $R_0 = P_H + k_S * u_0$ , where:  $k_S$  is a spring rate,  $u_0$  - hanger travel.

**Spring identification** comes from the corresponding spring table (catalog). The spring identification consists of 3 fields: 'size/travel/type' where "size" corresponds to the maximum load capacity of the spring, "travel" corresponds to the maximum allowable travel, the hanger type ("type") is used only in those catalogs, in which various springs are used in different design versions of spring hangers/supports (for example, LISEGA catalog).

**maximum travel of the spring** – spring travel between the minimum and maximum loads.

**chain** – set of springs connected sequentially

**chain structure** – number characterizing the maximum operating travel of the chain. In Russian standards, the springs with working travel of 70 mm (Z1) and 140 mm (Z2) mm are used. Then the coupling of several springs into a single assembly (chain) can be described as follows:

$$\begin{aligned} Z3 &= Z1 + Z2 \\ Z4 &= Z2 + Z2 \\ Z5 &= Z1 + Z2 + Z2 \\ Z6 &= Z2 + Z2 + Z2 \dots \text{etc.} \end{aligned}$$

For international standards, each consequent number of the chain structure corresponds to a spring with the larger operating travel. In selecting the springs, the concepts of maximum and minimum chain structures (**ZMAX** и **ZMIN**) are introduced, which corresponds to limitation of the maximum and minimum values of the working travel.

**load safety factor (PFAC)** – ratio of the maximum permissible load on spring,  $P_{MAX}$ , to the load, equal to  $\max(P_h, P_c)$ . In selecting the springs, the program provides the ratio of these values being equal or greater than the PFAC value. In the course of designing, the safety factor allows compensating the uncertainties related to the difference between the nominal weight of pipe taken in the analysis and the actual data, which can become known only during installation. Hence the introduction of load safety factor allows to correct the spring pre-load during installation, if necessary. On the other hand, the load safety factor enables the spring to perceive additional loads (for example, seismic loads).

**Load variation factor (PVAR)** – value to be determined by the following relation:

$$PVAR = \frac{|P_d - P_c|}{P_d}$$

The **SPR** command is used to define the spring support/hanger in dPIPE. The spring is identified by reference to the table (catalogue) and the spring size. For example, for a spring manufactured in accordance with OST 108.764.01-80 with a load capacity of 2005 kgf and a travel of 210 mm, the following command will be used in the dPIPE input data:

```
20: SPR nc = 1, id
    = '07/Z3' tb1
    'OST80'
```

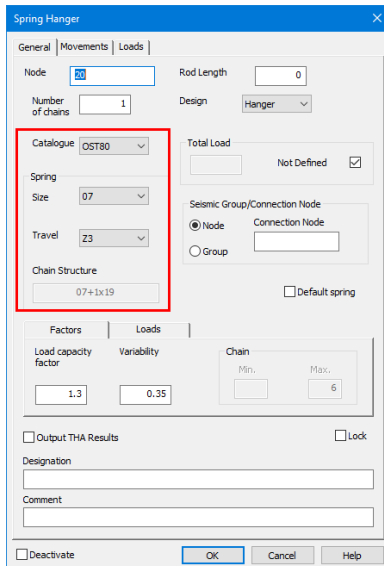

OST 108.764.01-80

λ (mm)	Pmax (kgf)												dPipe
	128	278	534	816	1190	1666	2005	2686	3325	4080	4956	5960	
70	01	02	03	04	05	06	07	08	09	10	11	12	Z1
140	13	14	15	16	17	18	19	20	21	22	23	24	Z2
210	01+13	02+14	03+15	04+16	05+17	06+18	07+19	08+20	09+21	10+22	11+23	12+24	Z3
280	13+13	14+14	15+15	16+16	17+17	18+18	19+19	20+20	21+21	22+22	23+23	24+24	Z4
350	01+13+13	02+14+14	03+15+15	04+16+16	05+17+17	06+18+18	07+19+19	08+20+20	09+21+21	10+22+22	11+23+23	12+24+24	Z5
420	13+13+13	14+14+14	15+15+15	16+16+16	17+17+17	18+18+18	19+19+19	20+20+20	21+21+21	22+22+22	23+23+23	24+24+24	Z6
	01	02	03	04	05	06	07	08	09	10	11	12	

MVN 049-63

λ (mm)	Pmax (kgf)													dPipe
	97	197	292	514	815	1155	1562	2050	2420	3420	4620	5720	6400	
70	11	12	13	14	15	16	17	18	19	20	24	25	Z1	
140	01	02	03	04	05	06	07	08	09	10	21	22	Z2	
210	01+11	02+12	03+13	04+14	05+15	06+16	07+17	08+18	09+19	10+20	21+24	22+25	Z3	
280	01+01	02+02	03+03	04+04	05+05	06+06	07+07	08+08	09+09	10+10	21+21	22+22	Z4	
350	01+01+11	02+02+12	03+03+13	04+04+14	05+05+15	06+06+16	07+07+17	08+08+18	09+09+19	10+10+20	21+21+24	22+22+25	Z5	
420	01+01+01	02+02+02	03+03+03	04+04+04	05+05+05	06+06+06	07+07+07	08+08+08	09+09+09	10+10+10	21+21+21	22+22+22	Z6	
	01	02	03	04	05	06	07	08	09	10	11	12	13	

## Run of analysis, errors and warnings

In order to select the characteristics of springs for hangers (supports), it is necessary to specify the "starting" set of computations in the specification for analysis, which is described in [Appendix V](#). The program performs the selection of spring characteristics depending upon the spring tables specified ([SDEF](#) command), load safety factor and load variation factors ([PFAC](#) and [PVAR](#) parameters of the [SPR](#) command) as well as the values of minimum and maximum chain structures ([ZMAX](#) and [ZMIN](#)). In case of successful completion of the "starting" set of computations, the program performs the execution of main analysis stages using the spring characteristics computed. In addition, a file of the type: <model name>.dp5\_ will be created in the working directory, which contains the data for hangers with computed characteristics of springs (further this file can be renamed into <model name1>.dp5 and used as the basic file for subsequent computations).

In case of unsuccessful completion of the starting set of computations, the program will stop its execution and will inform about the cause, according to which the selection of spring characteristics has failed. In order to analyze the causes for unsuccessful selection of springs, then intermediate results can be viewed in the listing of results or in the PIPE3DV program. After opening the PIPE3DV program and "activation" of the hangers, the red exclamation mark will be displayed in the upper right corner, and the "problem" supports will be flashing (the flashing can be activated - deactivated by the following combination of keys: *ALT-E*). Having placed the cursor to the hanger, clicking the right button of the mouse and selected the "Node parameters" item from the context menu, one can view information about the intermediate results.

Below most typical situations related to the failures during spring design are given and commented:

### *Example 1*

#### Diagram:

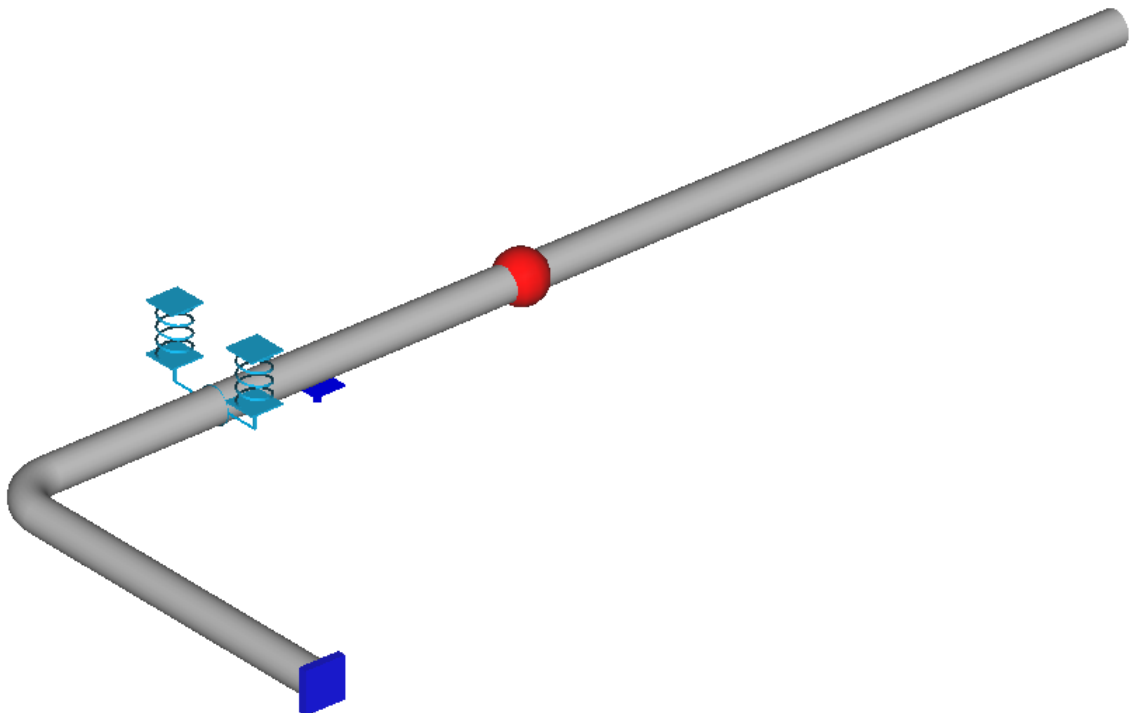

#### Program messages:

```

File Model_spring.bin was created successfully.
Solve > Op 1(R): W          -> done
Error: spring load out of working range

dPIPE 5 Post  Build 231213
POST: Design Load for spring hanger could not be defined
POST: See results

```

Comment:

Design Load could not be calculated ("restrained weight" Load Case, TYPE = 'DSGN'). It could happen if the reaction of the hanger turned out to be negative, i.e. a wrong place for spring hanger/support has been selected.

*Example 2*

Diagram:

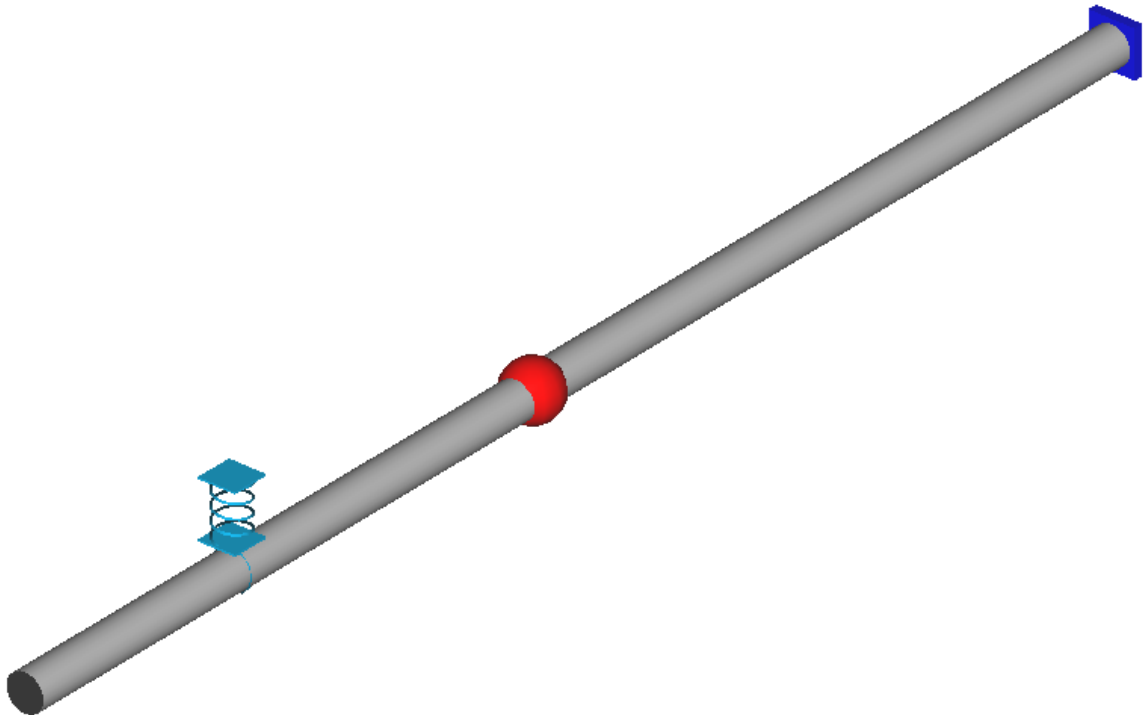

Program messages:

```

File Model_spring_straight.bin was created successfully.
Solve > Op 1(R): W          -> done
Solve > Op 1(A): W+P+T+D    -> done
Error: spring load out of working range

```

```

dPIPE 5 Post  Build 231213
POST: Design Load for spring hanger is out of range
POST: See results

```

Comment:

---

In this example, a very large weight of the valve has been specified intentionally, and the program cannot choose a spring with the required load capacity. Normally, in order to solve such kind of problems it is usually sufficient to increase the number of springs or install an additional supports.

*Example 3*

Diagram:

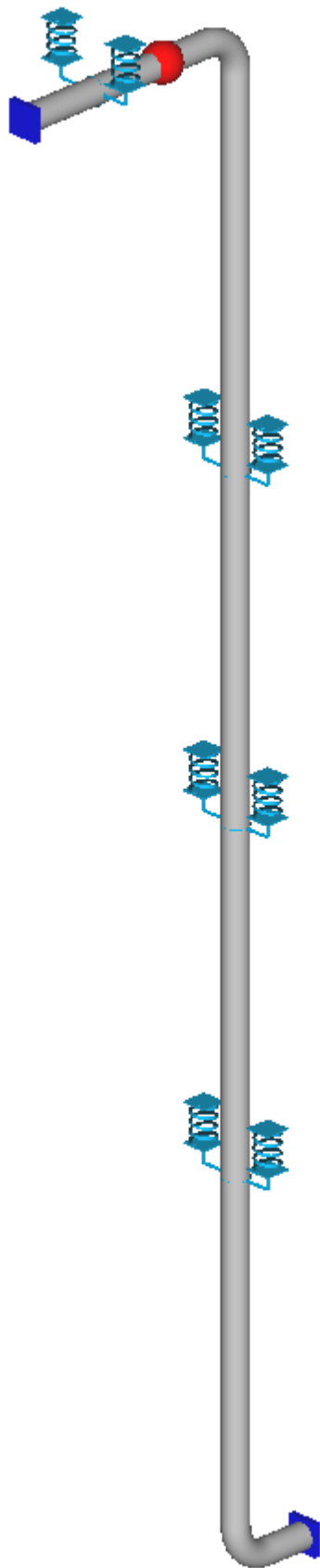

Program messages:

```
Solve > Op 1(R): W          -> 1/1
Solve > Op 1(R): W          -> done
Solve > Op 1(A): W+P+T+D    -> 1/1
Solve > Op 1(A): W+P+T+D    -> done
Solve > Cold(B): W+P+T+D    -> 1/1
Solve > Cold(B): W+P+T+D    -> done
Error: spring load out of working range
```

**dPIPE 5 Post Build 231213**

```
POST: Work travel for spring hanger is out of range (Pref > Pmax)
POST: See results
Stop - Program terminated.
```

Comment:

In this example, it has appeared impossible to select a spring for the reference load (Cold Load in the given case). At the third LC of starting computations the program checks the following condition:

$$P_{MIN} < Pref < P_{MAX}/PFAC$$

In case when this inequality is not valid, the program will try to select a spring with  $PFAC = 1$ . If it fails, then the program will terminate the execution of calculations with an error message being issued.

Such situations, as a rule, arise at large vertical temperature movements of the piping system. This problem can be solved only after analysis of the intermediate results: if the working load  $P_h$  on the hanger is close to the maximum and the piping being cooled moves down, then it is necessary to unload this hanger either by increasing the number of springs (NC) or by installing an additional supports carrying the weight load. Another method is to enable the program to select more flexible springs with a large working travel (for this purpose it is necessary to increase the ZMAX parameter). If no one of these solutions is satisfactory, then it is possible to use constant loads hangers (for example, from LISEGA catalog). For simulating such hangers, it is necessary to select a "user" spring in the program with the "zero" stiffness and required working load:

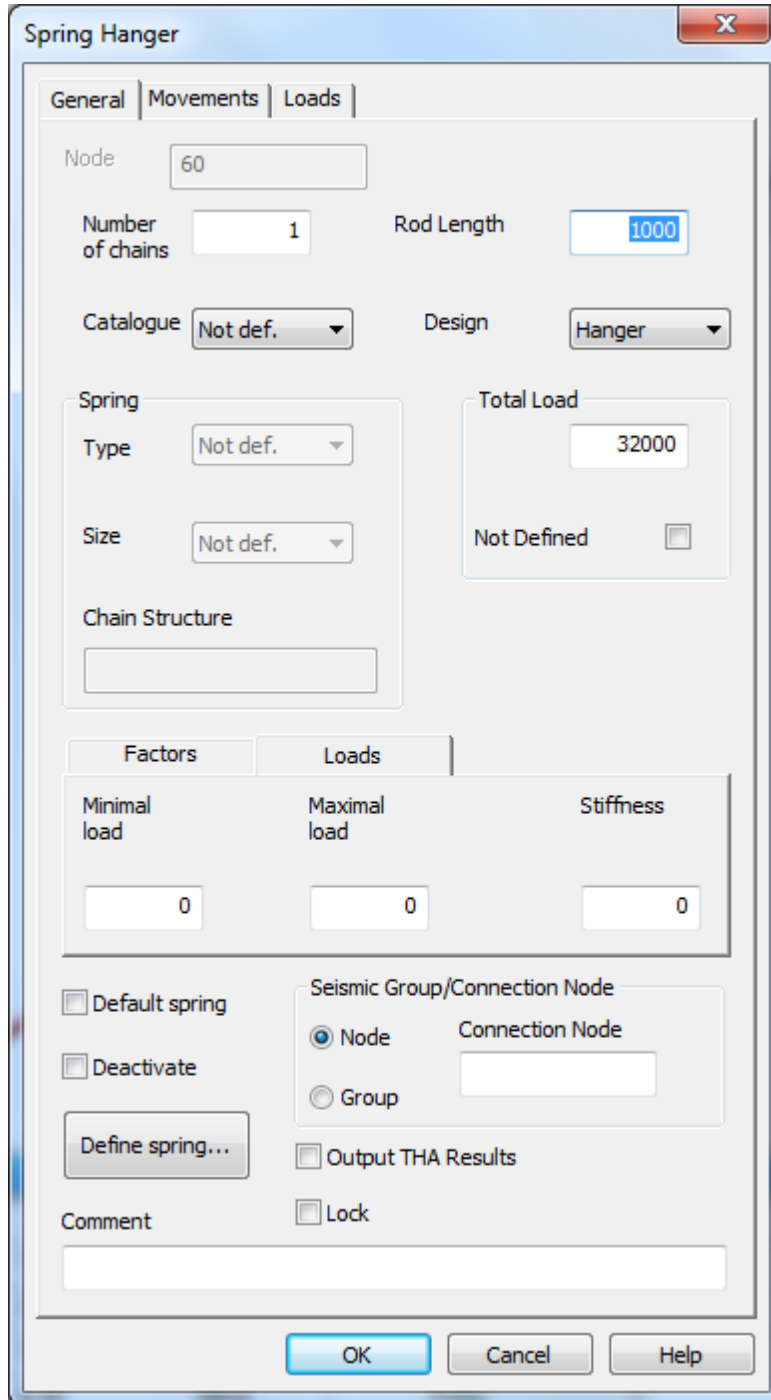

The image shows a 'Spring Hanger' dialog box with the following fields and options:

- General** tab selected.
- Node: 60
- Number of chains: 1
- Rod Length: 1000
- Catalogue: Not def.
- Design: Hanger
- Spring Type: Not def.
- Spring Size: Not def.
- Total Load: 32000
- Not Defined:
- Chain Structure: (empty text box)
- Factors** and **Loads** tabs.
- Minimal load: 0
- Maximal load: 0
- Stiffness: 0
- Default spring
- Deactivate
- Define spring... button
- Seismic Group/Connection Node:
  - Node
  - Group
  - Connection Node: (empty text box)
- Output THA Results
- Lock
- Comment: (empty text box)
- Buttons: OK, Cancel, Help

If in selecting the springs it turns out impossible to provide one of the required parameters (load safety factor *PEAC* or required variability *PVAR*), then the program will issue a warning and continue running:

```

Solve > Op 1(R): W                    -> done
Solve > Op 1(A): W+P+T+D+F            -> done
Warning: lift-off from one-way supports
Solve > Cold(B): W+P+T+D+F           -> done
Warning: spring load variation > desired
Solve > Op 1(B): W+P+T+D+F+FR+SW     -> done
Warning: lift-off from one-way supports
Solve > Op 1(C): W+P                  -> done
Solve > Cold(B): W+P+T+D+F+FR+SW     -> done

dPIPE 5 Post   Build 231213
POST: LS1      S2_NUE                LC5 SUM
POST: LS2      SRK                    LC4-LC6 SUM
POST: LS3      SAF                    LC4-LC6 SUM
POST: LS4      DISP                   LC5 SUM
POST: LS5      DISP                   LC4-LC6 SUM
POST: LS6      SUPP                   LC4 SUM
POST: LS7      SUPP                   LC6 SUM
POST: LS8      FORC                   LC4-LC5 SUM

```

In the example given, the message *"Warning: spring load variation > desired"* means that it failed to achieve fulfillment of the variability conditions ([PVAR](#)) for one or several hangers.

The message *"Warning: spring load safe factor < desired"* means that it failed to achieve fulfillment of the conditions for load safety factor ([PFAC](#)) for one or several hangers.

The message *"Warning: lift-off from one-way support"* means that at the corresponding stage of analysis one of the one-way supports has uplifted and cannot bear the load.

Further, in the course of viewing the results in PIPE3DV, the "problem" supports will be flashing, and the following message will be placed in the listing of results with summarized tables opposite these supports.

## Results of analysis

In case of successful completion of the analysis, the information about spring hangers/supports will be printed out in the following tables: "Spring Hanger Design Data." (file <>.sup). In this table, only the data for spring hangers/supports referenced to the catalogs included in the file sh.dbs will be printed. A separate table is printed for each catalog. For hangers from Russian standards (OCT, MVN), the table is printed in the following form:

```

>>> Spring Hanger Design Data. Catalogue OCT 108.764.01-80
=====
Sup N   NC   Chain      Springs Heights      Support's Loads      Movements      ALPHA
(node)  (node) struct. H_free H_hot H_cold H_inst P_hot P_cold P_seis  DX  DY  DZ
=====
N1      2   1*18      369   277   258   257   21.41 25.88      4  -1  19  0.1
=====
N2      1   1*06+    201   165   157   154   8.31  10.37     15  5  26  0.9
      1*18      369   298   280   275
=====
Notes:
NC          - number of springs
H_free     - unloaded spring height, mm
H_hot      - spring height in hot state, mm
H_cold     - spring height in cold state, mm
H_inst     - spring height before installation, mm
P_hot      - hot load, kN
P_cold     - cold load, kN
P_seis     - seismic load, kN
DX, DY, DZ - transient movements from cold to hot state, mm
ALPHA      - angularity (swing from the vertical), deg

```

The values of H\_hot., H\_cold., P\_hot and P\_cold. are printed in accordance with the [LOAD\\_HOT](#) and [LOAD\\_COLD](#) parameters. Similarly the computation of "movements" is performed. The value of H\_inst is recalculated according to the load  $R_0$  determined for LC with the type of 'OPER\_A'

encountered first in the analysis:

$$R_0 = P_h + \lambda_i \cdot k_s,$$

where  $k_s$  is the spring stiffness,  $\lambda_{ii}$  is the spring travel to be computed in the analysis of type 'OPER\_A'

For international standards this table is printed out in the following form:

>>> Spring Hanger Design Data. Catalogue Lisega cat.2010 Type 21/25/29/20

Sup N (node)	NC	Spring	Type	Spring Travel		Support's Loads			Movements			ALPHA
				Dh	Dc	P_hot	P_cold	P_seis	DX	DY	DZ	
N1	2	5/2	21 25	30	50	10.70	13.27		4	-2	19	0.1
N2	1	5/3	21 25	25	53	8.32	10.17		15	4	28	0.9
N3	2	5/2	21 25	22	36	9.62	11.52		26	7	14	0.8
N4	1	5/1	21 25	16	13	10.87	10.00		40	5	-3	2.8
N5	1	5/1	21 25	23	22	12.68	12.48		67	24	-1	5.9
N6	1	5/1	21 25	26	31	13.56	14.94		91	44	5	8.6
N7	1	5/2	21 25	51	65	13.40	15.28		78	51	14	8.1

Notes:

NC - number of springs  
 Dc, Dh - relative spring travel, mm (as marked on the scale)  
 P\_hot - hot load per one spring, kN  
 P\_cold - cold load per one spring, kN  
 P\_seis - seismic load per one spring, kN  
 DX, DY, DZ - transient movements from cold to hot state, mm  
 ALPHA - angularity (swing from the vertical), deg

Unlike Russian standards, the values are printed in this table, which are normally indicated on the spring's name plate, e.g. load on the spring in the working (hot) and cold states as well as the position of movement indicator (deformation of spring). The same as in the previous table, the printing of values for the cold and hot states is performed in accordance with the [LOAD\\_HOT](#) and [LOAD\\_COLD](#) parameters. If these parameters are not defined, then the corresponding table columns are not completed.

>>> Summary table for spring hangers loads

SUP N (node)	spring	P_des	P_oper	FS	var	DX	DY	DZ	ALPHA	load set
N1	5/2	21.45	21.41 26.53	1.6 1.5	0 24	2 -1	-7 -5	20 1	0.2 0.1	LS006 LS007
N2	5/3	8.35	8.32 10.17	1.2 1.5	0 22	12 -3	-5 -9	34 6	0.7 0.5	LS006 LS007
N7	5/2	13.46	13.40 15.28	1.5 1.3	0 14	76 -2	52 0	16 2	8.0 0.2	LS006 LS007

Notes:

P\_des - design load, kN  
 P\_oper - operational load, kN  
 FS - load safety factor  
 var - variability, %  
 DX, DY, DZ - movements, mm  
 ALPHA - angularity (swing from the vertical), deg

LS006 - нагрузки в раб. состоянии (Этап 2)  
 LS007 - нагрузки в хол. состоянии (Этап 4)

The number of lines for each support is determined by the number of corresponding directives in the POST (res=TYPE') command. The value of P<sub>np</sub> is taken from the calculation having the type of 'dsgn' or from the calculation specified by the [LOAD\\_DES](#) parameter. The value of variability is determined for each state with respect to the design load. For combinations of loads including seismic ones, the variability value is not printed.

#### **Individual tables for each strong hanger/support.**

In addition to the tables mentioned above, for each flexible support in the <model name>.sup file, the table of the following form will be printed out:

```
>>> Node:          N1
Support spring hanger, number of springs: NC = 2, Rod Length L = 2050 mm

Spring :          5/2 (LISEGA). (Maximal travel - 100 mm)

Design load:      21451 N
Theoretical installation load: 26696 N
```

---

	P	Pmax (Newton)	Pmin		DISP mm	LOAD kN	Var %
1 Нагрузки в раб. состоянии	21405	40000	13320	1.61	30	10.7	0
2 Нагрузки в хол. состоянии	26531	40000	13320	1.51	50	13.3	24

---

```
types: 21 25

Displacements:
```

---

	Dx	Dy (millimeters)	Dz	ALPHA deg
1 Нагрузки в раб. состоянии	2.37	-7.15	19.83	0.2
2 Нагрузки в хол. состоянии	-1.29	-5.05	0.62	0.1

---

The same table is displayed in the PIPE3DV program in the course of viewing the "information about the node". The numbers printed in this table are determined according to the rules given above for similar values.

In case of successful selection of spring characteristics in the <model name>.res file the summarized table with all hangers will be printed out:

```
>>> Table 1 . Results of spring's selection (load for one spring)
```

Node	NC	Spring	K	Pmin	Pmax	Pd	Ph	Pc	R0	TRAVEL	var	FS
N1	2	06/Z2	116.7	0	16338	9309	9291	11525	11603	19	24	1.42
N2	1	4/2	66.7	3330	10000	7246	7218	8990	9501	27	24	1.11
...												
N7	1	5/2	133.4	6660	20000	11691	11641	13516	13827	14	16	1.48

---

```
Notes:
NC - number of springs
K - spring's stiffness, N/mm
Pmax - maximal load, N
Pmin - minimal load, N
Pd - design load, N
Ph - hot state load, N
Pc - cold state load, N
R0 - theoretical presetting load, N
TRAVEL - operation travel, mm
var - variability, %
FS - load safety factor: FS = MIN ( Pmax/MAX(Ph,Pc); MIN(Ph,Pc)/Pmin )
```

And in case when errors arise, this table has the following form:

```
ERROR MESSAGES:
Fail to select spring matched to operational load
```

warning and error messages

```
>>> Table 1 . Results of spring's selection (load for one spring)
```

Node	NC	Spring	K	Pmin	Pmax	Pd	Ph	Pc	R0	TRAVEL	var	FS
210	2	7/1		20000	60000	45304	45304					1.32
<b>70</b>	<b>2</b>			<b>40</b>	<b>100000</b>	<b>219186</b>	<b>219186</b>					<b>0.46 (FS !)</b>
80	2	6/1		13330	40000	37000	37000					1.08
90	2	7/1		20000	60000	60000	60000					1.00

---

for hangers, which characteristics were failed to determine the minimum and maximum spring loads are printed according to the corresponding table of the springs

## SH.DBS file structure

The file contains the description of spring characteristics (spring tables) in accordance with the manufacturers' industrial standards. The table rows correspond to the maximum values of the "working travel" of spring, columns – to the maximum load, which the spring can perceive.

The following commands and parameters are used for description of the spring tables.

**\$TITLE** *"Name" "Description"*:

*"Name"* – name of standard being used in the [SDEF](#) command ([STAB](#) parameter). *"Description"* – information about the standard.

**\$UNIT\_LOAD** *'load' coef*- command that specifies the conversion factor for the dimension of loads given in the catalog with respect to newtons;

**\$UNIT\_DISP** *'disp' coef*- command that specifies the conversion factor for the dimension of movements given in the catalog with respect to millimeters;

**\$LOAD\_MIN** *load<sub>1</sub>, load<sub>2</sub> ... load<sub>n</sub>* – value of the minimum load for each of the spring type-sizes;

**\$LOAD\_MAX** *load<sub>1</sub>, load<sub>2</sub> ... load<sub>n</sub>* – value of the maximum load for each of the spring type-sizes;

**\$WRK\_RANGE** *disp<sub>1</sub>, disp<sub>2</sub>, ... disp<sub>k</sub>* – values of maximum possible deformations of springs (working travel);

**\$LAB\_SIZE** *'size<sub>1</sub>' 'size<sub>2</sub>' ... 'size<sub>n</sub>'* – marks corresponding to the loads

**\$LAB\_TYPE** *'type<sub>1</sub>' 'type<sub>2</sub>' ... 'type<sub>k</sub>'* – marks corresponding to the spring deformations

**\$Z1\_HEIGHT** *hght<sub>1</sub>, hght<sub>2</sub> ... hght<sub>n</sub>* – heights of springs with the working travel of 70 mm in a free state (to be used only for domestic standards: OST 108.764.01-80, MVN 049-63, OST 24.125.109-93)

**\$Z2\_HEIGHT** *hght<sub>1</sub>, hght<sub>2</sub> ... hght<sub>n</sub>* – heights of springs with the working travel of 140 mm in a free state (to be used only for domestic standards: OST 108.764.01-80, MVN 049-63, OST 24.125.109-93)

**\$Z1\_DESIGN** *'lab<sub>1</sub>' 'lab<sub>2</sub>' ... 'lab<sub>n</sub>'* – marks for identification of springs with the working travel of 70 mm from domestic catalogs

**\$Z2\_DESIGN** *'lab<sub>1</sub>' 'lab<sub>2</sub>' ... 'lab<sub>n</sub>'* – marks for identification of springs with the working travel of 140 mm from domestic catalogs

**\$SPR\_PTTRN** *XXXXX<sub>1</sub> XXXXX<sub>2</sub> ... XXXXX<sub>n</sub>* – pattern to determine whether this spring type-size with the corresponding working travel exists: 0 – missing, 1 – present; the number of figures in the pattern shall correspond to the dimension of the \$WRK\_RANGE array

**\$TYPES** *'type<sub>1</sub>' 'type<sub>2</sub>' ... 'type<sub>j</sub>'* – marks for possible design versions of springs;

**\$TYP\_PTRN** *X<sub>1</sub> X<sub>2</sub> ... X<sub>j</sub>* - pattern for the design versions of springs: 0 – this design version is available only for spring hangers; 1 - this design version is available only for spring supports;

**\$TYP\_MASK** – integer array with the size repeating the spring table. Each integer is a "bit mask" with available types of design versions for each type-size of springs

**\$PFAC** – [PFAC](#) parameter recommended for this table

**\$PVAR** – [PVAR](#) parameter recommended for this table

**\$ZMIN** – [ZMIN](#) parameter recommended for this table

**\$ZMAX** – [ZMAX](#) parameter recommended for this table

For each spring table the presence of the following commands: \$TITLE, \$UNIT\_LOAD, \$UNIT\_DISP, \$LOAD\_MIN, \$LOAD\_MAX, \$WRK\_RANGE, \$LAB\_SIZE and \$LAB\_TYPE is mandatory. The rest of commands can be specified or not depending upon the corresponding catalog.

In this program version, the file SH.DBS contains the spring tables for the following standards:

Title	Description of standard
OST80	OST 108.764.01-80
MVN63	MVN 049-63
OST93	OST 24.125.109-93
LISEGA	LISEGA Catalog "Standard supports 2010", Product group 2, spring hangers, spring supports, Types: 21, 25, 29, 20
LISEGA_E	LISEGA Catalog "Standard supports 2010", Product group 2, spring hangers, spring supports, Types: 22, 26, 28
GRADIOR	<a href="#">GRADIOR "PIPE SUPPORTS CATALOGUE"</a> , Spring Supports: types 1-4 (hangers), 7 - supports
WTZNMAN	<a href="#">"Pipe Hangers and Supports" Catalogue</a> , Series FHD, FHG, FHS and FDT for spring hangers, FSS, FSP - for spring supports
UNISONS	<a href="#">"Variable spring hanger"</a> Unison eTech Catalogue, Springs VSS (30 mm travel)
UNISONML	<a href="#">"Variable spring hanger"</a> Unison eTech Catalogue, Springs VSM (65 mm travel) and VSL (130 mm travel)
T2	Springs with travel 50, 100 and 200 mm and load capacity from 0 to 100 kN (table 12.2) from "TITAN2, Catalogue EN. Standard elements for piping supports for ISO 4200:1991 pipes". Types 51, 52, 53
T2_XL	Springs with travel 50, 100 and 200 mm and load capacity from 53.3 to 400 kN (table 12.4) from "TITAN2, Catalogue EN. Standard elements for piping supports for ISO 4200:1991 pipes". Types 54, 55, 56
T2_RU	Springs with travel 70 and 140 mm and load capacity from 0 to 58.5 kN (table 12.3) from "TITAN2, Catalogue EN. Standard elements for piping supports for ISO 4200:1991 pipes". Types 51, 52

## Selection of springs from LISEGA Catalog

Springs from LISEGA Catalog (product group 2, [REF 6](#)) differ by types (design versions), load capacity and by the range of spring's travels. The catalog contains 5 variants of the working travel: 50, 100, 200, 300 and 400 mm. In doing so, the last two variants *"The use of extra long springs is only to be recommended in limited cases because of the relatively large spring hysteresis"* [REF 6](#).

LISEGA offers the following types of springs:

For hangers (supports) with load capacity **up to 100 kN**

**Type 21 and Type 25** are the most frequently used springs for hangers and differ by the design version:



Type 21



Type 25

**Type 29** - is used for spring supports.

**Type 20** - Angulating spring support. Unlike spring supports of Type 29, this design can perceive horizontal movements without lateral forces arising due to friction forces:

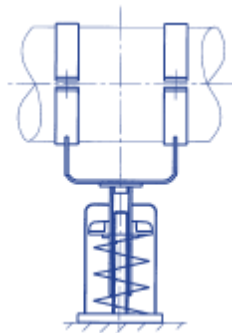

Type 29

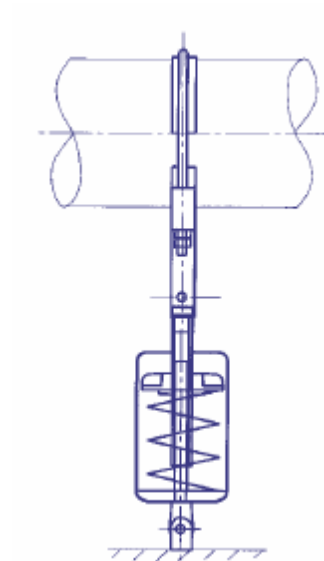

Type 20

For hangers (supports) with load capacity **from 160 kN to 400 kN** the spring assembly are used:

**Type 22** – spring hangers (similar to Type 21):

**Type 26** – spring hangers (seated) (similar to Type 25):

**Type 28** – spring supports (similar to Type 29)



Type 22

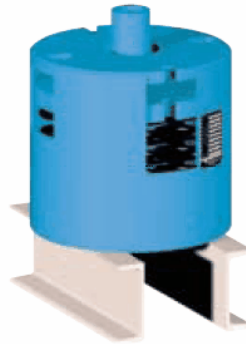

Type 26



Type 28

For these types of springs only the first 3 ranges of maximum working travels are possible (from 50 to 200 mm).

In addition to the spring types listed above, the catalog offers "sway braces" (Type 27) and spring hanger trapezes (Type 79). These types are not considered herein below.

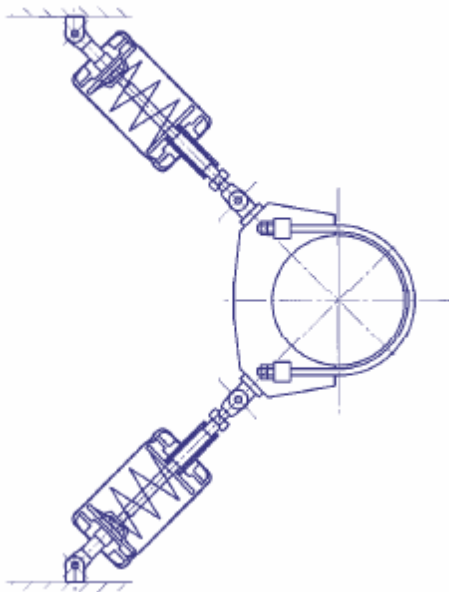

Type 27



Type 29

The springs of types 21, 25, 29 and 20 are included in the spring hanger database file (SH.DBS) under the "LISEGA" Table. Springs with increased load capacity (types 22, 26 and 28) are contained in "LISEGA\_E" table.

The recommended values of parameters affecting the spring design when the LISEGA Catalog is used ([SDEF](#) and [SPR](#) commands) are as follows:

$$ZMIN = 1; ZMAX = 3; PFAC = 1.1, PVAR = 0.25$$

To set the identification of a spring from the LISEGA catalog in dPIPE, the following fields from the spring designation are used: the first 2 digits are the spring design, the third digit corresponds to the load group, the

fourth digit is the travel range, the last 2 digits determine the production series and in the spring code are not used. For example, the spring "21C219" is specified by the following command:

*10: SPR nc = 1, tbl = 'LISEGA', id = 'C/2/21', note = "21C219"*

The screenshot shows the 'Spring Hanger' dialog box with the following configuration:

- General Tab:**
  - Node: 10
  - Rod Length: 0
  - Number of chains: 1
  - Design: 21
  - Catalogue: LISEGA
  - Spring Size: C
  - Travel: 2
  - Total Load: Not Defined
  - Seismic Group/Connection Node: Node
  - Chain Structure: (empty)
  - Default spring: (unchecked)
- Loads Tab:**
  - Load capacity factor: 1.1
  - Variability factor: 0.25
  - Chain Min.: (empty)
  - Chain Max.: 5
- Other Options:**
  - Output THA Results: (unchecked)
  - Lock: (unchecked)
  - Designation: 21C219
  - Comment: (empty)
- Buttons:** Deactivate, OK, Cancel, Help

## 16 Appendix VII

### Consideration of cold springing in piping system design and analysis.

Cold-springing is a fabrication of piping to an actual length shorter than its nominal length so that it is stressed in the installed condition, thus compensating partially for the effects produced by expansion due to an increase in temperature.

In using the cold springing, it is necessary to take into account the following circumstances:

- cold spring reduces the loads on equipment in the hot state and increases them in the cold state;
- during installation of the piping system it is difficult to provide the required tolerance of the cold spring and further, in the course of operation of the piping system, it is impossible to control it. Taking into account this factor, a number of international stress codes for piping systems (ASME BPVC NB 3600, ASME B31.3), require to perform allowance for only 2/3 of the cold spring design value in determination of loads on supports and equipment in the working (hot) state and the full value of the cold spring in determination of loads in the cold state;
- the cold springing does not affect the stress range between the hot and cold states, and, therefore, it shall not be taken into account for computation of the corresponding stress categories;
- the relaxation of stresses due to thermal expansion in high-temperature piping systems leads to the cold springing of the piping system in the cold state irrespective of the use of the cold spring. The effect of use of the cold spring shows itself only at the initial stage of the piping system operation.

Within the framework of dPIPE program, the cold spring is specified, on the one hand, in the form of an analysis model element (see [CS](#) command) and, on the other hand, it is necessary to indicate the cold spring in the specification for analysis as a load component (*load* parameter, [SOLV](#) command). The standard specifications for analysis for the PNAE and RD Codes contain the recommended set of commands for taking into account the cold spring.

## 17 Appendix VIII

### **Effect of non-uniform temperature distribution over the height of piping system cross-section (thermal stratification).**

The thermal stratification arises in the horizontal segments of the piping system as a result of mixing the two flows of the working fluid with different temperatures and low velocities. Under certain operating conditions, due to this effect, the non-linear temperature distribution occurs over the height of piping system cross-section, which leads to additional temperature stress that can be divided into the following two categories:

- global bending stress caused by the thermal stratification top-to-bottom gradient: the upper part of the pipe tends to expand at higher temperatures, and the colder (lower) part of the pipe restrains these expansions and vice versa;
- a local stratification stress is produced by the nonlinearities in the top to bottom temperature distribution

It should be noted that the existing strength analysis codes for piping systems do not consider stratification as the design load, however in the course of operation of the piping system the stratification effect can influence on supports and equipment as well as on the fatigue strength.

The following procedure has been implemented within the framework of the dPIPE program for taking account of the stratification:

similar to the approach given in ASME NB-3653.2 for the temperatures gradient over the wall thickness of the piping system, the temperature distribution over the cross-section height of the piping can be presented by superposition of the following three parts:  $T$  – constant part,  $V$  – linear portion with zero average value and  $\Delta T_3$  – a non-linear portion with zero average value and a zero first moment across the pipe diameter.

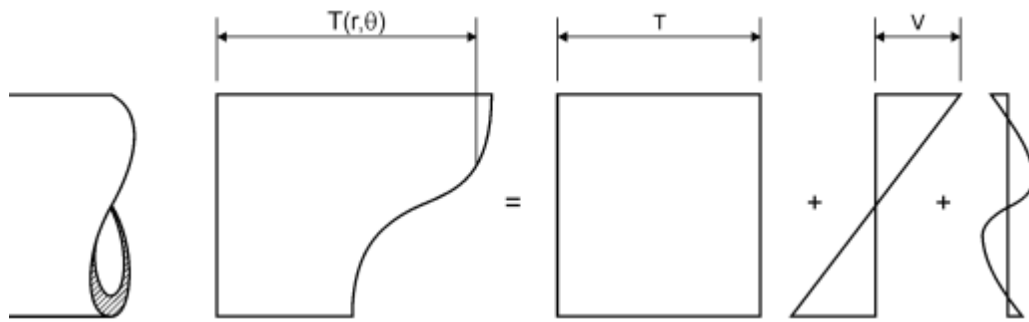

Decomposition of Stratification Temperature Distribution Range.

The following formulae can be used for determination of the above-mentioned parameters:

$$T = \frac{2}{\pi(r_o^2 - r_i^2)} \int_{-\pi/2}^{\pi/2} \int_{r_i}^{r_o} r T(r, \theta) dr d\theta$$

$$V = \frac{6}{\pi(r_o^3 - r_i^3)} \int_{-\pi/2}^{\pi/2} \int_{r_i}^{r_o} r^2 T(r, \theta) \sin \theta dr d\theta$$

$$\Delta T_3 = \max\{|T(r, \theta) - T - Vr \sin \theta / r_o|\}$$

where

$T(r, \theta)$  – function of distribution of temperature over the cross-section depending upon the radius and the angle, °C,

$r_o$  – outside radius of pipe, mm

$r_i$  – internal radius of pipe, mm

$\theta$  – angle to be counted from the horizontal central line of the cross-section

$r$  – coordinate along the radius

After determination of the values of  $V$  and  $\Delta T_3$  (these parameters are described by the STRAT and DT3 identifiers respectively, see [GRAD](#) command), the program will compute the distributed bending moment  $M_{eq}$ , which complements the load from thermal expansions:

$$M_{eq} = \frac{E * I * \alpha * V}{D_0}$$

where

$E$  – Young modulus (of elasticity) of the pipe material (MPa);

$I$  – moment of inertia of the piping cross-section (mm<sup>4</sup>);

$\alpha$  – temperature expansion coefficient (mm/mm/°C);

$V$  – linear component of the temperature distribution, °C;

$D_0$  – outside diameter of the pipe, mm.

In order to take into account the load from stratification for the specified case of analysis, it is necessary to indicate the "BOW" identifier in the [LOAD](#) parameter ([SOLV](#) command) (for example,  $LOAD=P+T+W+BOW$ ). It should be noted that only those segments of the piping system that lie in the horizontal plane will be loaded by the distributed bending moment  $M_{eq}$  ([BOW\\_PITCH](#) parameter of the [CTRL](#) command establishes the acceptable deviation of pipe from the horizontal plane).

- in conducting the estimation of the fatigue strength according to the ASME NB-3600 Codes, equation 11 (NB-3653.2), the calculation of local peak stress shall be supplemented by the following part:  $E\alpha|\Delta T_3|$  where  $|\Delta T_3|$  is the maximum value of the non-linear component of the stratification temperature distribution, °C.
- within the framework of analysis according to the PNAE Codes, the additive  $E\alpha|\Delta T_3|$  shall be taken into account in computation of the stress of category  $(\sigma_{aF})_K$ . To do this, one should explicitly define these stresses by [STRESS](#) parameter.

## 18 Appendix IX

### Pressure Elongation in piping system

When piping is pressurized, its entire inner surface is subjected to a uniform pressure loading. This pressure loading creates stresses in the directions normal to the wall, parallel to the pipe axis, and tangential to the cross sectional circle:

- hoop stresses:

$$\sigma_h = \frac{P \cdot D}{2t}$$

- longitudinal stresses:

$$\sigma_z = \frac{P \cdot D}{4t}$$

where

P – internal pressure; D – mean diameter of the piping system; t – wall thickness.

At the same time it elongates the pipe again in the axial and circumferential directions. The stretch in the axial direction is generally referred to as **pressure elongation**.

As a rule, these components of stresses are taken into account directly (without computation of internal forces) in the corresponding formulae set forth in the Strength analysis codes for piping systems in combination with permanent loads (weight + pressure). However, apart from the above-mentioned stresses, the internal pressure cause radial and longitudinal deformations in the piping system:

$$\varepsilon_h = \frac{\sigma_h}{E} - \frac{\mu \cdot \sigma_z}{E} = \frac{P \cdot D}{2 \cdot t \cdot E} (1 - 0.5 \mu) \quad \text{and} \quad \varepsilon_z = \frac{\sigma_z}{E} - \frac{\mu \cdot \sigma_h}{E} = \frac{P \cdot D}{4 \cdot t \cdot E} (1 - 2 \mu)$$

where

$\varepsilon_h$  – hoop strain,  $\varepsilon_z$  – longitudinal strain, E – modulus of elasticity,  $\mu$  - Poisson's coefficient.

And if the hoop strain, due to the absence of their restraint, can be neglected, then the allowance for internal pressure, from the point of view of longitudinal deformations, can, in certain cases, make a contribution comparable with temperature expansions. In order to evaluate this effect, it is possible to use the formula for conversion of the equivalent temperature corresponding to the piping system deformation from internal pressure:

$$\Delta T_{eq} = \frac{P \cdot D}{4 \cdot t \cdot E \cdot \alpha} (1 - 2\mu)$$

where  $\alpha$  is the temperature coefficient of linear expansion.

For most piping systems being operated at high temperatures on plants, this effect is insignificant and  $\Delta T$  is equal to a value of about 5-10 °C but for extent thin-walled piping systems being operated at moderate temperatures, the value of equivalent temperature can reach 40 - 50 °C. In doing so, additional loads on supports and connected equipment arise in the piping system apart from stresses caused by its tension due to pressure.

As the load caused by "tension" of the piping system under the action of internal pressure, is, by its nature, related to self-balanced (secondary) load, then the effect of piping system tension due to internal pressure shall be taken into account in combination with deformation loads (temperature expansions and displacements of supports) and the additional stresses shall be evaluated by the corresponding stress categories.

In dPIPE, the allowance for axial deformations from internal pressure has been implemented by introduction of the **PE** option (**SOLV** command). If necessary, for the corresponding case of analysis this flag should be set as PE = 'YES':

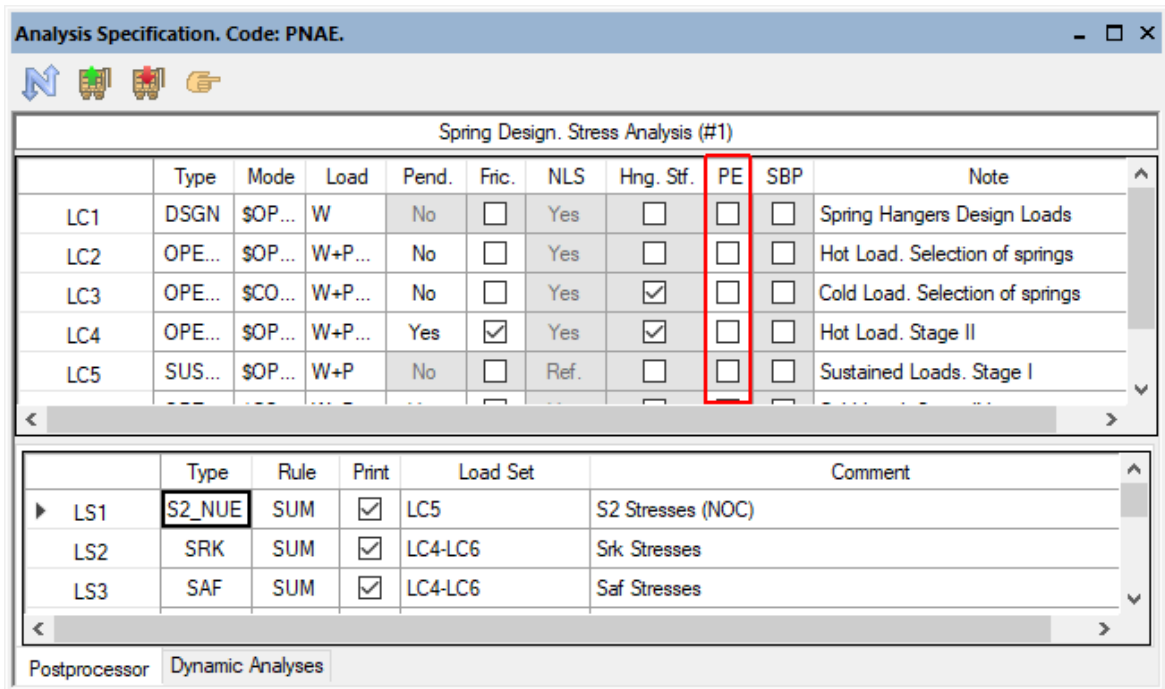

## 19 Appendix X

### Assessment of loads on the valve nozzles

The assessment is performed in accordance with the document: "Piping valves for nuclear plants. General technical requirements NP-068-05", [REF 14]. The data from Appendix 8 to this document have been recorded in the database contained in the "[vlv\\_ott.dbs](#)" file. This file has a text format and the following structure:

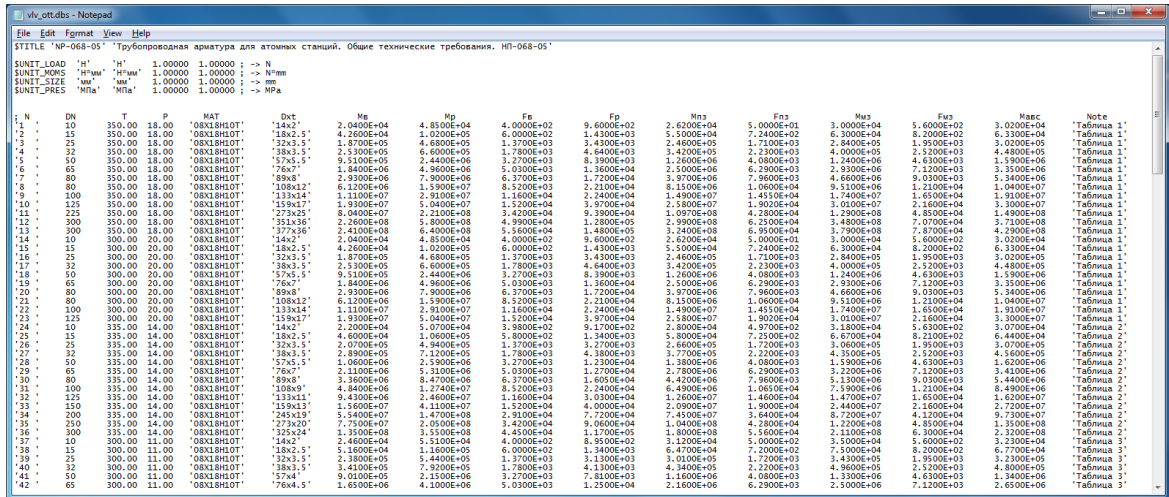

The first line, command : \$TITLE contains a short and full description of the document:

\$TITLE 'NP-068-05' 'Piping valves for nuclear plants. General technical requirements NP-068-05'

Commands: \$UNIT\_XXX determine the measurement unit system and conversion factors (from one measurement unit system into another) for the data contained in the database:

```
$UNIT_LOAD 'H' 'H' 1.00000 1.00000 ; -> N
$UNIT_MOMS 'H*MM' 'H*MM' 1.00000 1.00000 ; -> N*mm
$UNIT_SIZE 'MM' 'MM' 1.00000 1.00000 ; -> mm
$UNIT_PRES 'MПа' 'MПа' 1.00000 1.00000 ; -> MPa
```

where

**\$UNIT\_LOAD** - measurement unit system for forces; **\$UNIT\_MOMS** - measurement unit system for moments; **\$UNIT\_SIZE** - measurement unit system for linear dimensions; **\$UNIT\_PRES** - measurement unit system for pressure

Blank lines and lines beginning from the semicolon sing ";" will be interpreted by the program as comment.

The data themselves consist of a set of records (lines) consisting of 16 values (columns):

Designation	Column number	Value	Format
N	1	record identifier	<a href="#">TEXT</a>
DN	2	nominal diameter	<a href="#">INTEGER</a>
T	3	design temperature	<a href="#">REAL</a>
P	4	design pressure	<a href="#">REAL</a>
MAT	5	material	<a href="#">TEXT</a>
Dxt	6	dimensions of connecting pipes	<a href="#">TEXT</a>
Mw	7	moment from the piping weight	<a href="#">REAL</a>
Mr	8	range of moment from thermal expansion of the piping system	<a href="#">REAL</a>
Fw	9	force from piping weight	<a href="#">REAL</a>
Fr	10	range of force from thermal expansion	<a href="#">REAL</a>
Mobe	11	moment and force from the joint action of the piping	<a href="#">REAL</a>
Fobe	12	weight and OBE	<a href="#">REAL</a>

Msse	13	moment and force from the joint action of the piping weight and SSE	<a href="#">REAL</a>
Fsse	14		<a href="#">REAL</a>
Memerg.	15	moment from the joint action of the piping weight and reactive force in case of piping system rupture	<a href="#">REAL</a>
Note	16	comment (reference to table from Appendix 8)	<a href="#">TEXT</a>

Referencing a certain valve ([V](#), [V1](#), [V2](#), [VA](#), [VO](#) commands) to the database is performed via the corresponding dialogs with the use of the *OTT\_REF* parameter. In case when the "Select" button is pressed, the following dialog appears:

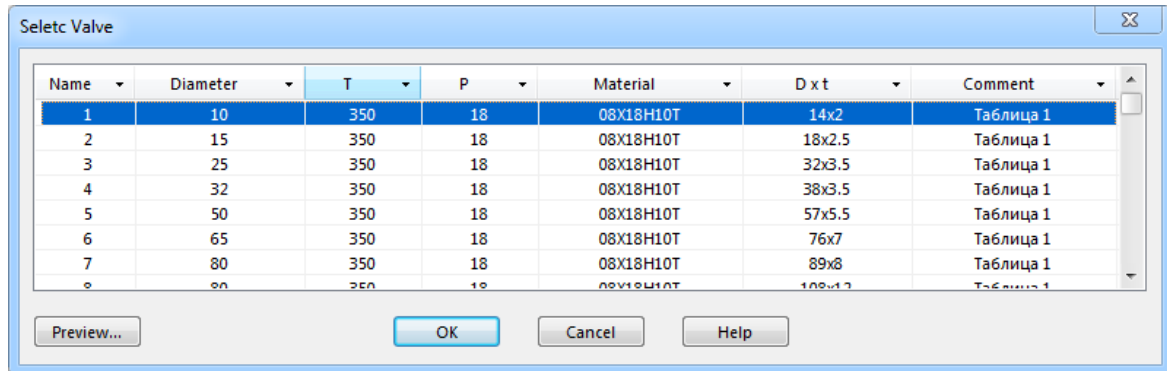

In order to select the required record in this dialog, one can use the integrated filters. For example, in order to select the allowable loads for the electrically driven shutoff bellows DN 100, PN=20 MPa, T=300 °C from stainless steel, it is necessary to execute the following operations:

1. Click on the "Diameter" title and select the nominal diameter 100 by a double click:

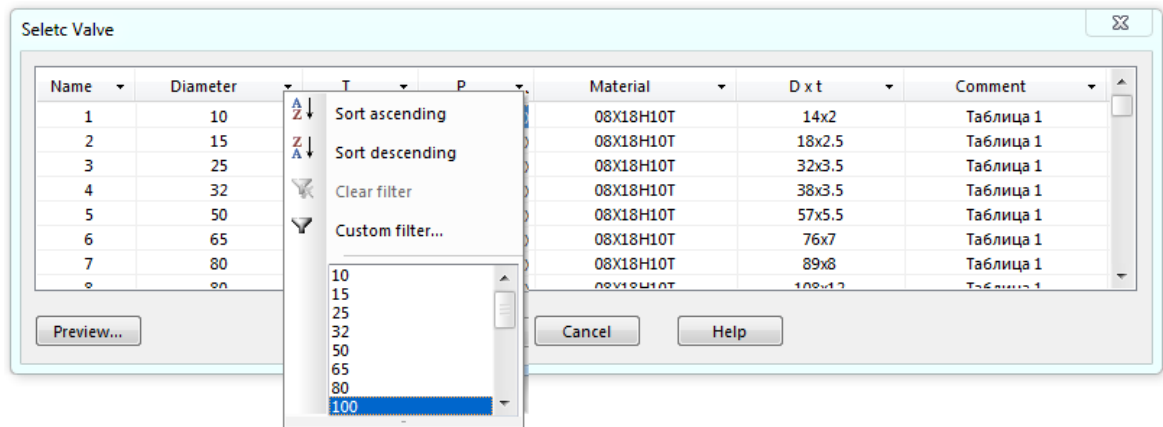

2. Click on the "Temperature" title and select the temperature 300 by a double click:

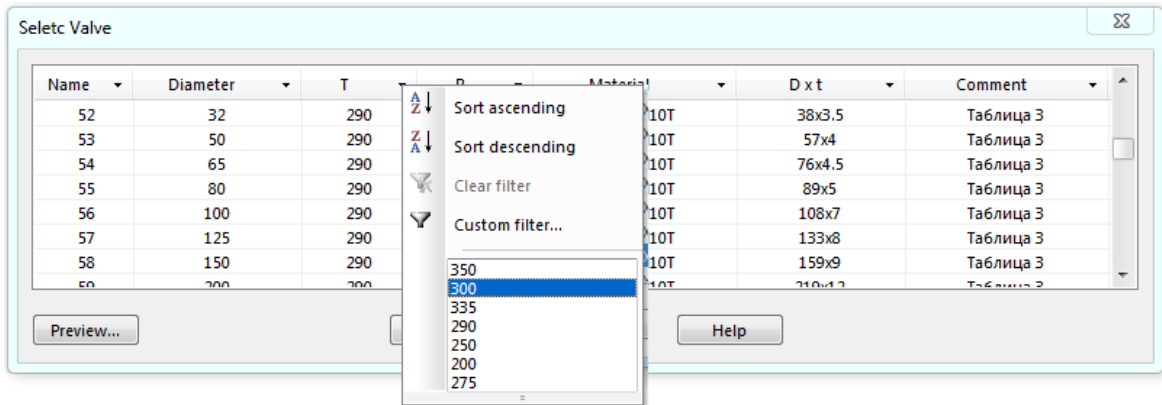

3. Form the remaining data in the table, select the required record and press OK:

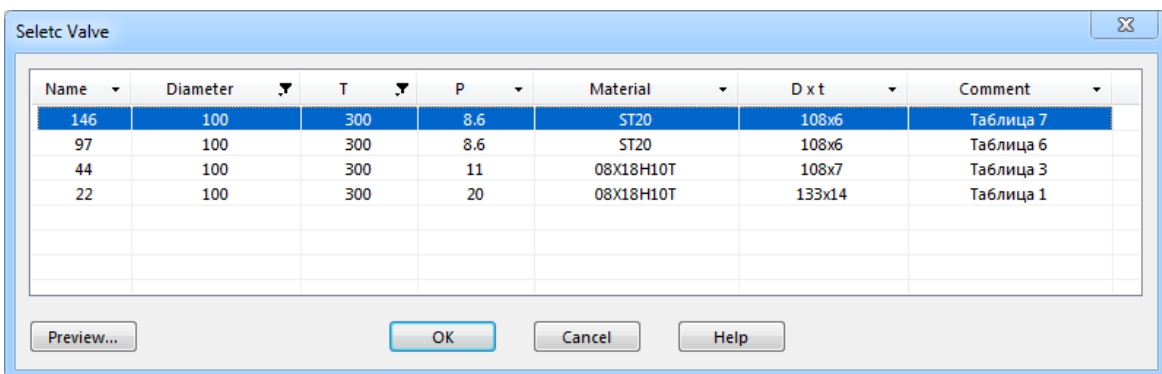

Using the "View" button you can preview the values of allowable loads:

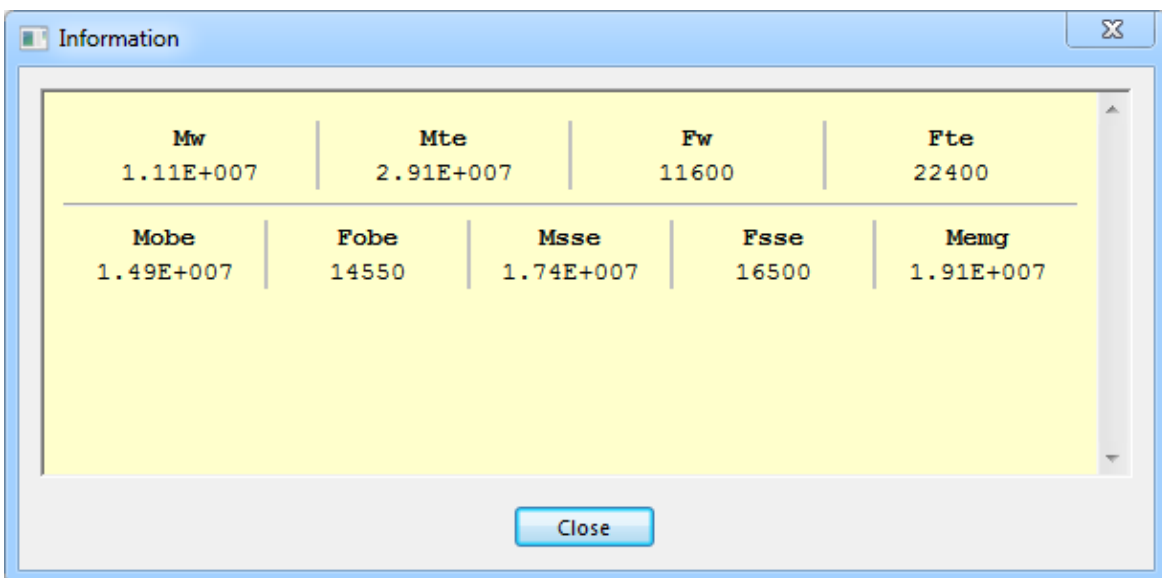

In addition, in the "[Options/Reports/Valves](#)" dialog, it is necessary to specify the corresponding references for LC & LS so that the assessment of loads on the valve nozzles should be performed.

Upon execution of analysis, two tables will appear in the file with the input data listing, *<model name>.out*, containing information about the links between the valve data and the reference to the database record as well as a table with the values of allowable loads:

>>> Table 11. Assessment of valve's nozzle loads according to NP-068-05

designation	Node 1	Node 2	body mass	actuator	label	DN	Dxs	Pd	Td	material	
10LCQ25AA201	2460	6230	≠0000028		80	80	89x5	2.5	250.0	08x18H10T	таблица 5
10LCQ35AA201	3760	3770	≠0000029		80	80	89x5	2.5	250.0	08x18H10T	таблица 5
10LCQ15AA201	5090	5100	≠0000030		80	80	89x5	2.5	250.0	08x18H10T	таблица 5
10LCQ45AA201	6410	6420	≠0000031		80	80	89x5	2.5	250.0	08x18H10T	таблица 5
вход охлаждающ 1	1780	6110			58	150	159x9	9.2	290.0	08x18H10T	таблица 3

>>> Table 11.a Allowable loads for valve's nozzles according to NP-068-05

label	Fw	Mw	Ft	Mt	Fobe	Mobe	Fsse	Msse	Memerg
80	4.000E+03	2.330E+06	5.940E+03	3.450E+06	4.900E+03	2.870E+06	5.610E+03	3.230E+06	3.460E+06
58	1.520E+04	1.320E+07	3.880E+04	3.370E+07	1.900E+04	1.750E+07	2.160E+04	2.030E+07	2.190E+07

Notes:

Fw, Mw - resulting force and moment from the weight loads: H, H\*MM  
 Ft, Mt - range of force and moment due to thermal expansion: H, H\*MM  
 Fobe, Mobe - force and moment due to weight and seismic (OBE) loads: H, H\*MM  
 Fmpз, Mmpз - force and moment due to weight and seismic (SSE) loads: H, H\*MM  
 Mавс - moment due to weight and emergency loads: H\*MM

The results of analysis will be recorded in a file with summary tables, <model name>.sup, in the form of a table containing ratios of the design values to the allowable ones:

>>> Assessment of valve's nozzle loads according to NP-068-05 (demand to capacity ratio)

designation	Fw	Mw	Fr	Mr	Fobe	Mobe	Fsse	Msse	Memr	Ab_h	Ab_v	Aa_h
10LCQ25AA201	0.007	0.081	0.067	0.287	0.263	0.483	0.454	0.803	-	1.78	0.36	-
10LCQ35AA201	0.003	0.087	0.322	0.206	0.091	0.307	0.158	0.494	-	1.75	0.30	-
10LCQ15AA201	0.000	0.025	0.100	0.251	0.236	0.332	0.411	0.573	-	1.63	0.27	-
10LCQ45AA201	0.006	0.087	0.233	0.239	0.076	0.344	0.128	0.550	-	1.70	0.26	-
вход охлажда	0.004	0.024	0.102	0.241	0.105	0.253	0.182	0.421	-	0.33	0.22	-

Notes:

Fw, Mw - force and moment from the weight loads;  
 Fr, Mr - range of force and moment from the thermal expansion loads  
 Fobe, Mobe - force and moment from the OBE loads;  
 Fsse, Msse - force and moment from the SSE loads;  
 Memr - moment from combination of weight load and reactive load due to pipe break  
 Ab\_h, Ab\_v, Aa\_h - horizontal (h) and vertical (v) accelerations of the valve's body and actuator (in g)

In case of the seismic load being present in the analysis, the values of horizontal and vertical accelerations of the valve housing center of mass will additionally be printed out in comparison with the values of 3g in the horizontal direction and 2g in the vertical direction for the valve housing and 8g in the horizontal direction for the valve drive center of mass.

## 20 Appendix XI

### ASME BPVC Codes. NB/NC-3600 sections. Stress Indices

#### NC\_3600

NC-3600, 1992 (CODE = 'ASME\_NC', CODE\_YEAR = '1992', TRN command, TYPE = 'BRC')

NC-3000 — DESIGN

Fig. NC-3673.2(b)-2

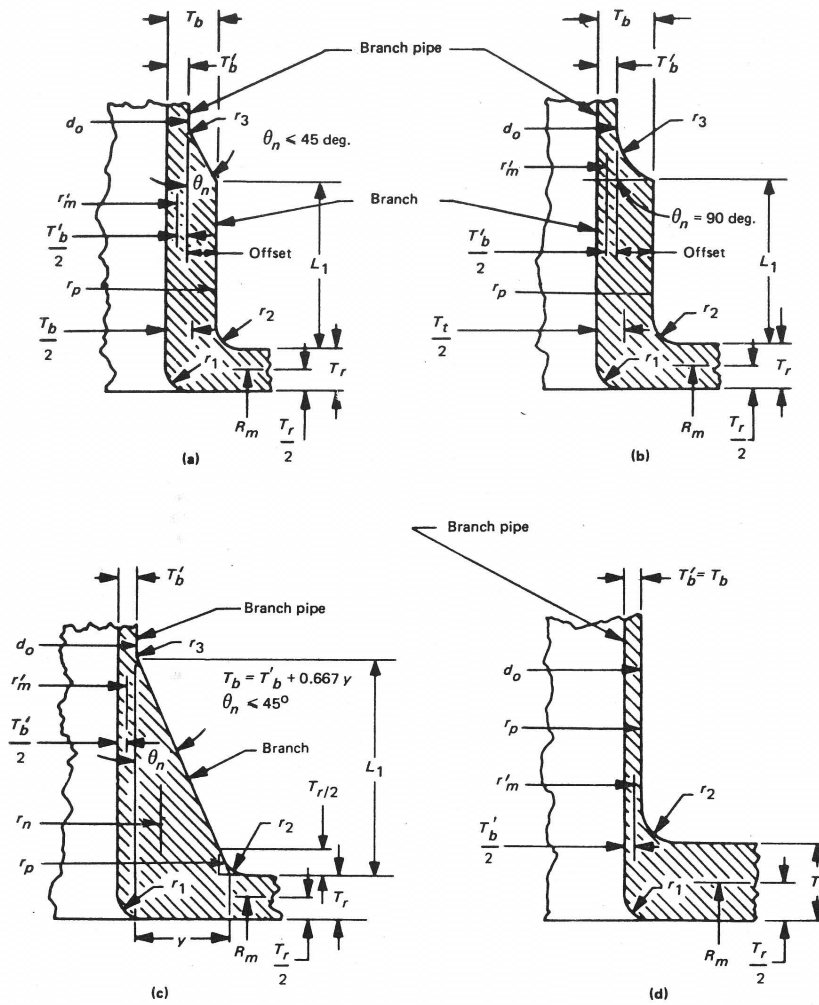

$d_o$  = outside diameter of branch pipe, in.  
 $r_m$  = mean radius of branch pipe in.  
 $T_b$  = nominal thickness of branch pipes, in.  
 $R_m$  = mean radius of run pipe, in.  
 $T_r$  = nominal thickness of run pipe, in.

GENERAL NOTES:  
 (1)  $T_b$ ,  $\theta$ ,  $r_1$ ,  $r_2$ ,  $r_3$ ,  $r_p$ , and  $y$  are defined in this figure.  
 (2) If  $L_1$  equals or exceeds  $0.5 \sqrt{r_1 T_b}$  then  $r'_m$  can be taken as the radius to the center of  $T_b$ .

FIG. NC-3673.2(b)-2 BRANCH DIMENSIONS

NC-3600, 2010 (CODE = 'ASME\_NC', CODE\_YEAR = '2010', TRN command, TYPE = 'BRC')

FIG. NC-3673.2(b)-2 BRANCH CONNECTION NOMENCLATURE

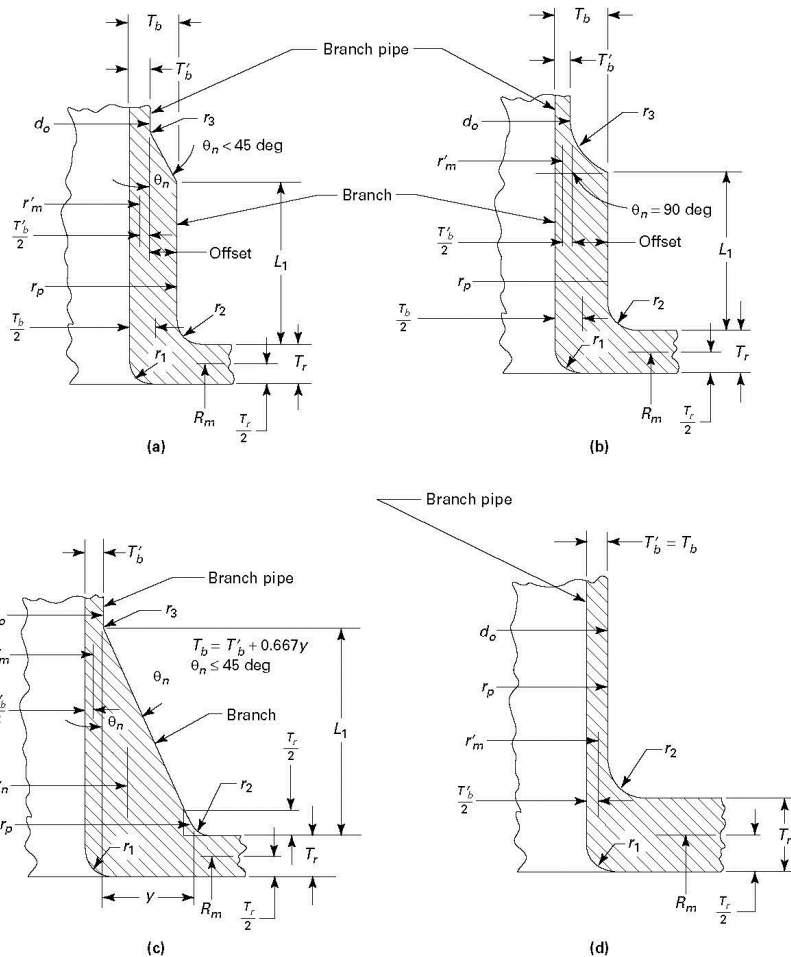

$d_o$  = outside diameter of branch pipe, in. (mm)  
 $r'_m$  = mean radius of branch pipe, in. (mm)  
 $T'_b$  = nominal thickness of branch pipes, in. (mm)  
 $R_m$  = mean radius of run pipe, in. (mm)  
 $T_r$  = nominal thickness of run pipe, in. (mm)

GENERAL NOTES:

(a)  $T_b$ ,  $\theta$ ,  $r_1$ ,  $r_2$ ,  $r_3$ ,  $r_p$ , and  $y$  are defined in this figure.

2010 SECTION III, DIVISION 1 — NC

FIG. NC-3643.2(b)-2 TYPICAL RIGHT ANGLE BRANCH CONNECTIONS MADE USING A FILLET WELD OR A PARTIAL PENETRATION WELD

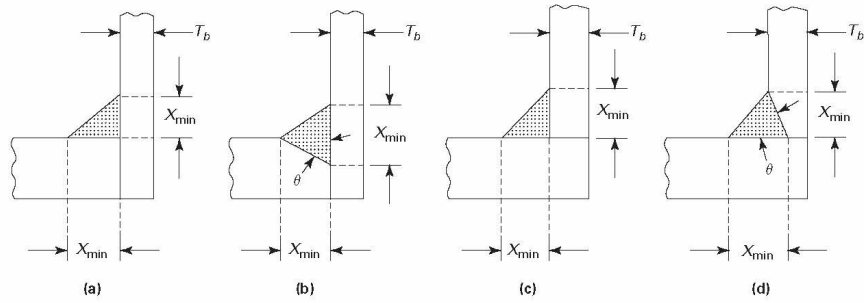

$T_b$  = nominal branch pipe wall thickness  
 $X_{min} = 1\frac{1}{4} T_b$   
 $\theta$  = partial penetration weld groove angle  $\geq 45$  deg

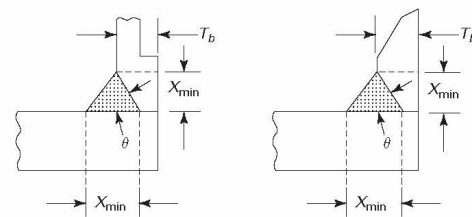

(e) ASME B16.11 Coupling (f) Welded Outlet Fitting

$T_b$  = fitting wall thickness in the reinforcement zone (when the fitting is tapered in the reinforcement zone, use average wall thickness)  
 $X_{min} = 1\frac{1}{4} T_b$   
 $\theta$  = partial penetration weld groove angle  $\geq 45$  deg

**NB\_3600**

**NB-3600, 1992 (CODE = 'ASME\_NB', CODE\_YEAR = '1992', TRN command, TYPE = 'BRC')**

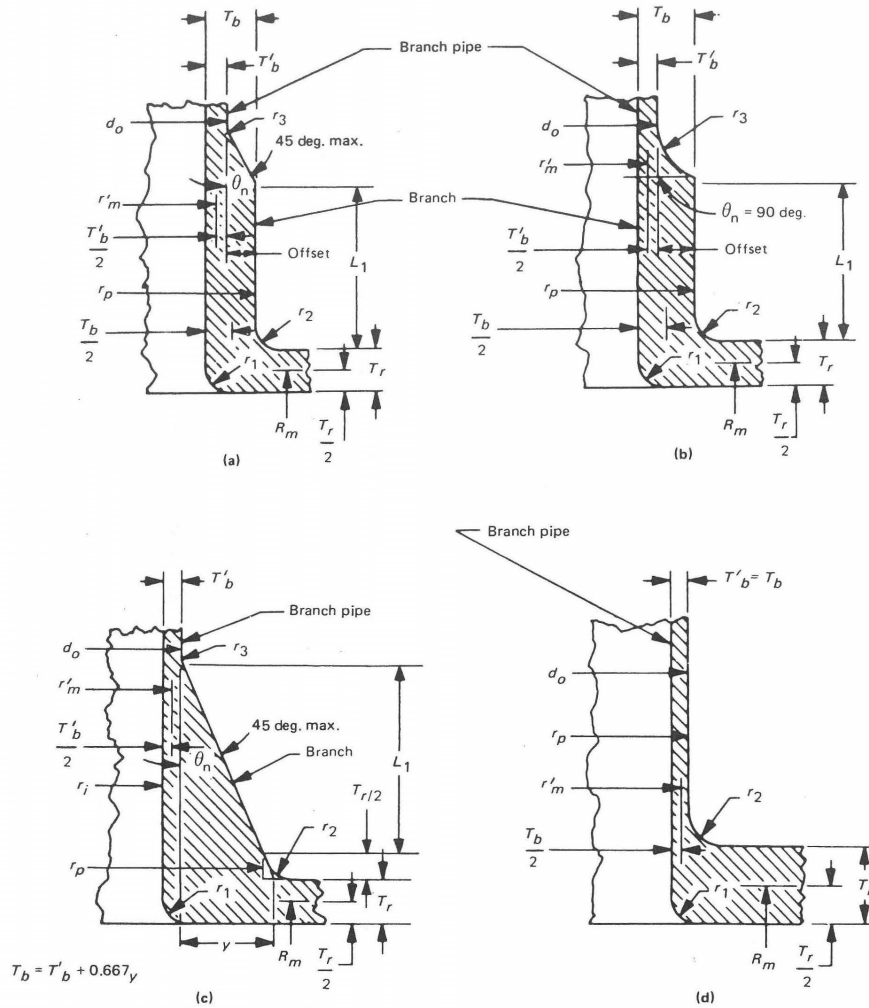

GENERAL NOTE:

If  $L_1$  equals or exceeds  $0.5 \sqrt{r_i T_b}$ , then  $r'_m$  can be taken as the radius to the center of  $T_b$ .

FIG. NB-3643.3(a)-1 BRANCH CONNECTION NOMENCLATURE

**NB-3600, 2010 (CODE = 'ASME\_NB', CODE\_YEAR = '2010', TRN command, TYPE = 'BRC')**

2010 SECTION III, DIVISION 1 — NB

FIG. NB-3643.3(a)-1 BRANCH CONNECTION NOMENCLATURE

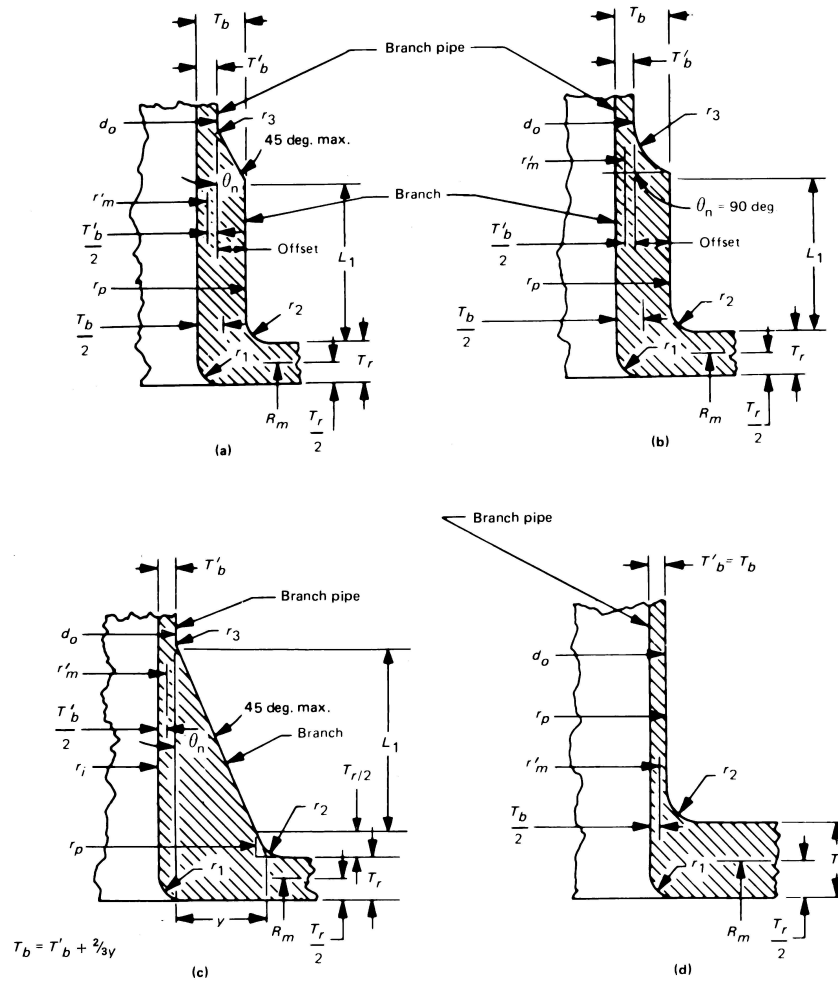

## 21 Appendix XII

### Structure of the database with Pipe supports Allowable loads

After installation of the program the file with database in MS Access format containing pipe supports allowable loads is located in the following folder: ...\\dPIPE 5.XX\\DB\\sup\_ids.mdb. The MS Access program itself is not required for PC operation but it can become necessary if the User independently determines to edit the database.

**General structure of the database:**

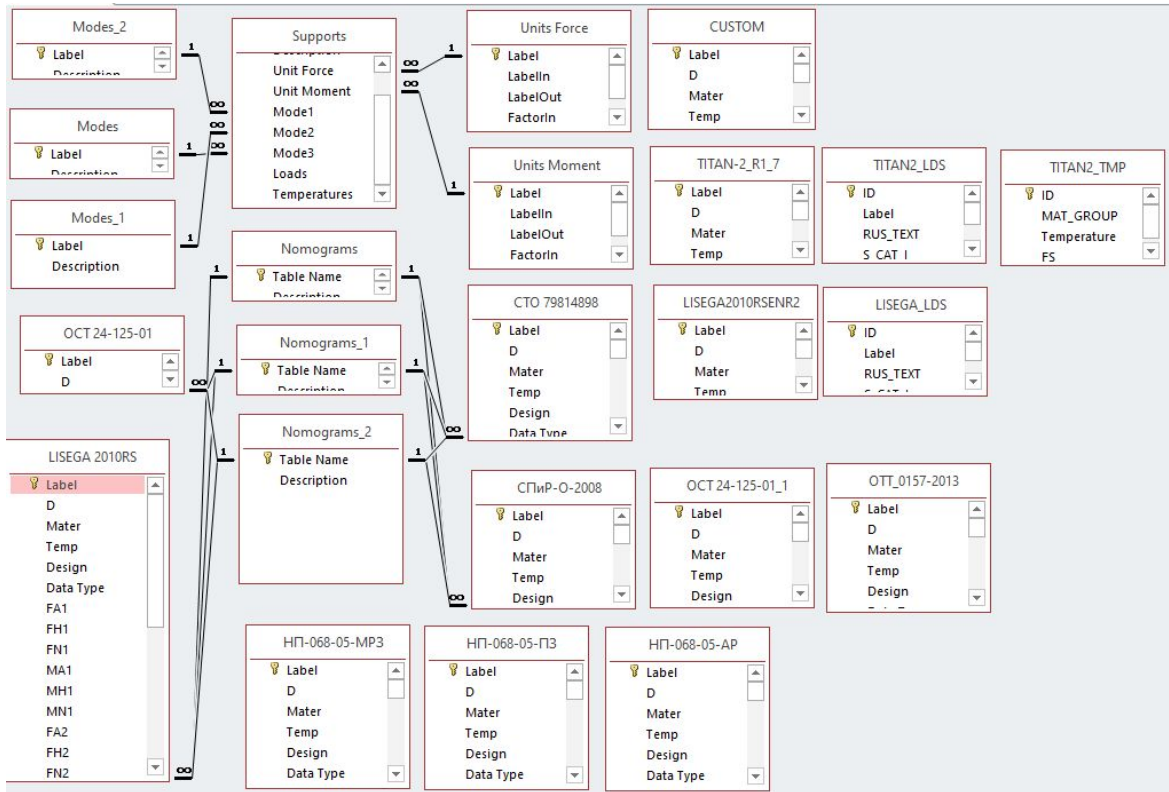

**Description of the main DB tables:**

➤ **«Supports»** table with a list of standards being present in DB:

Table Name	Description	Unit Force	Unit Moment	Mode 1	Mode2	Mode3	Loads	Temperatures
CUSTOM	Table for the Custom input	Newton	Newton*m	NOC	HT	NOC+OBE		
LISEGA 2010RS	LISEGA. Standard Supports 2010 RS. Document No. 900081-4	Kilowton	Newton*m	NOC	NOC+SS E	NOC+OBE		
LISEGA2010 RSEN2	Standard Supports 2010 RS EN, Document No.: 902205, Rev. 2	Kilowton	Newton*m	N/A	N/A	N/A	LISEGA_LDS	

OTT_0157-2013	Support structures of WWER NPP elements, OTT 1.5.2.01.999.0157-2013	Kilone wton	Knewton*m	OTT_1.0	OTT_1.4	OTT_1.5		
TITAN-2_R1_7	Catalog of standard supports for ISO 4200 1991 pipes	Kilone wton	Newton*m	N/A	N/A	N/A	TITAN2_LDS	TITAN2_TMP
TITAN-2_R2_SPB_0	Standard elements of supporting structures for piping manufactured in accordance with ISO 4200:1991, OST, STO, M 1001.8282.500.00, R1.7_1.4	Kilone wton	Newton*m	N/A	N/A	N/A	TITAN2_LDS_R2	TITAN2_TMP_R2
НП-068-05-AP	Piping valves for nuclear power plants. OTT	Newton	Newton*mm	Weight	Temperature	Weight+Emergency		
НП-068-05-MP3	Piping valves for nuclear power plants. OTT	Newton	Newton*mm	Weight	Temperature	Weight+SSE		
НП-068-05-П3	Piping valves for nuclear power plants. OTT	Newton	Newton*mm	Weight	Temperature	Weight+OBE		
ОСТ 24-125-01	Permissible loads for supports of high-pressure pipes. OST 24.125-01	Newton	Newton*mm	NOC	NOC+SSE	NOC+OBE		
СПиР-О-2008	Allowable Loads for Standard Support Structures (Appendix O-2)	Kilone wton	KNewton*m	NOC	NOC+SSE	NOC+OBE		
СТО 79814898	Supports for NPP piping working under pressure up to 4.0 MPa	Newton	Newton*mm	NOC	NOC+SSE	NOC+OBE		
HIPAC	HIPAC. Cryogenic Pipe Supports Type 56 / Type 57, Edition August 2018	Kilone wton	Newton*m	NOC				
Л8	Piping Supports and hangers, DN<89 mm	Kilone wton	Newton*m	NOC				

**Fields:**

Field Name	Data Type	Field Size	Descriptor
Table Name	Short Text	16	Name of the table
Description	Short Text	128	Table Description

Unit Force	Short Text	16	The label used for the units of force, reference to the "Units Force"
Unit Moment	Short Text	16	The label used for the units of moments, reference to the "Units Force"
Model	Short Text	16	Description of the operational mode "MOD1"
Mode2	Short Text	16	Description of the operational mode "MOD2"
Mode3	Short Text	16	Description of the operational mode "MOD3"
Loads	Short Text	255	The name of the table with amplification factors used for scaling nominal loads depending on load combination and pipe's <a href="#">seismic category</a>
Temperatures	Short Text	255	The name of the table with correction factors used for scaling nominal loads depending on the piping operational temperature

- The "**Modes**" table with a description of the operational modes, which are referenced by the Mode1, Mode2 and Mode3 fields of the [SUPPORTS](#) table:

Label	Description
HT	Hydraulic Test
N/A	not applicable
NOC	Normal Operation Conditions
NOC+OBE	NOC+OBE
NOC+SSE	NOC+SSE
OTT_1.0	AF = 1.0
OTT_1.4	AF = 1.4
OTT_1.5	AF = 1.5
Weight	Weight loads
Weight+Emergency	Combination of weight and piping break loads
Weight+SSE	Combination of weight and SSE loads
Weight+OBE	Combination of weight and OBE loads
HT	Hydraulic Test
NOC	NOC, normal operation conditions
NOC+SSE	Combination of NOC and SSE loads (applicable only for <a href="#">seismic category</a> I pipes)
NOC+OBE	Combination of NOC and OBE loads (applicable only for <a href="#">seismic category</a> II pipes)
Temperature	Thermal expansion loads

**Fields:**

Field Name	Data Type	Field Size	Descriptor
Label	TEXT	16	Short name of the Mode (will be shown in the printouts)

Description	TEXT	64	Mode Description (will be shown in the printouts)
-------------	------	----	---

- «**Nomograms**» Table with references to the nomograms, which are used for determination of permissible loads:

Supports		Nomograms	
Table Name	Description		
Table 001	D = 273, НУЭ, Рис. 5.24		
Table 002	D = 325, НУЭ, Рис. 5.25		
Table 003	D = 377, НУЭ, Рис. 5.26		
Table 004	D = 426, НУЭ, Рис. 5.27		
Table 005	D = 465, НУЭ, Рис. 5.28		
Table 006	D = 530, НУЭ, Рис. 5.29		

Fields:

Field Name	Data Type	Field Size	Descriptor
Table Name	TEXT	16	Table Name
Description	TEXT	64	Description/Comment

- Spreadsheet containing digital nomograms (**Table 001, Table 002 ... Table 069**):

Table 001			
_ID	FH	FV	A
1	0	978.7	
2	7142.8	5016.2	
3	10212	6716.2	

Fields:

Table 001		Table 006	
Field Name	Data Type	Description	
_ID	AutoNumber	AutoNumber	
FH	Number	Horizontal Reaction	
FV	Number	Vertical Reaction	

«**Units Force**» Table with measurement units for forces:

Units Force					
Label	LabelIn	LabelOut	FactorIn	FactorOut	A
Kilonewton	kN	N	1000	1	
Newton	N	N	1	1	

- «**Units Moments**» Table with measurement units for moments, :

Units Moment					
Label	LabelIn	LabelOut	FactorIn	FactorOut	A
Newton*m	N*m	N*mm	1000	1	
Newton*mm	N*mm	N*mm	1	1	

Fields:

Field Name	Data Type	Field Size	Descriptor
------------	-----------	------------	------------

Label	Text	16	Name of the Unit
LabelIn	Text	8	Abbreviation of input units
LabelOut	Text	8	Abbreviation of output units
FactorIn	Number	-	Conversion factor between input units and Newton
FactorOut	Number	-	Conversion factor between Newton and output units

➤ Spreadsheets with values of permissible loads on supports

Temp	Design	Data Type	FA1	FH1	FN1	MA1	MH1	MN1	FA2	FH2
200	1		0	0	0	9800	0	0	0	0
200	19		0	0	0	150100	0	0	0	0
200	92		0	0	12500	44500	0	0	0	17500
200	94		0	0	13000	46500	0	0	0	18000
200	96		0	0	20500	54500	0	0	0	28000
200	98		0	0	24000	61500	0	0	0	33000
200	100		0	0	27000	68000	0	0	0	37500
200	102		0	0	29000	71500	0	0	0	40500
200	104		0	0	46500	123000	0	0	0	64000
200	106		0	0	66000	126500	0	0	0	90000
200	108		0	0	72500	126500	0	0	0	100000
200	1		0	0	0	3000	0	0	0	0
200	21		0	0	0	157200	0	0	0	0
200	3		0	0	0	5500	0	0	0	0
200	5		0	0	0	7000	0	0	0	0
200	7		0	0	0	11500	0	0	0	0

Fields:

Field name	Data type	Field Size	Description
Label	Text	8	Label of the current record (for reference in the <a href="#">DBS_REF</a> parameter )
D	Text	8	Nominal diameter of the piping system; it is used as auxiliary information
Mater	Text	16	Type of the piping system material (CS - carbon steel, AUS - austenite steel, SS - stainless steel); it is used as auxiliary information, see <a href="#">Note (4)</a>
Temp	Text	8	Temperature, C; it is used as auxiliary information
Design	Text	16	Support designation in the corresponding catalog; it is used as auxiliary information and appears in printouts
Data Type	Number	-	Data type: integer from 0 to 4; see <a href="#">Note (1)</a>
FA1	Number	-	Set of permissible loads for the first mode indicated in parameters <a href="#">MODE</a> и <a href="#">LOAD</a> of the <a href="#">SUP_LOADS</a> command, see <a href="#">Note (2)</a>
FH1	Number		
FN1	Number		
MA1	Number		
MH1	Number		
MN1	Number		

FA2	Number	-	Set of permissible loads for the second mode indicated in parameters <a href="#">MODE</a> и <a href="#">LOAD</a> of the <a href="#">SUP_LOADS</a> command, see <a href="#">Note (2)</a> .
FH2	Number		
FN2	Number		
MA2	Number		
MH2	Number		
MN2	Number		
FA3	Number	-	Set of permissible loads for the third mode indicated in parameters <a href="#">MODE</a> и <a href="#">LOAD</a> of the <a href="#">SUP_LOADS</a> command, see <a href="#">Note (2)</a> .
FH3	Number		
FN3	Number		
MA3	Number		
MH3	Number		
MN3	Number		
Nomogram1	Text	16	It is used if DataType = 2: name of spreadsheet with digital nomogram for the first analysis mode
Nomogram2	Text	16	It is used if DataType = 2: name of spreadsheet with digital nomogram for the second analysis mode
Nomogram3	Text	16	It is used if DataType = 2: name of spreadsheet with digital nomogram for the third analysis mode
Sup Type	Text	8	Type of support (ANC, NZL, SUP, STG, etc.); it is used as auxiliary information
Note	Text	255	Comment; it is used as auxiliary information

Note:

- 1) Data type - integer, which specifies the processing of permissible loads:
  - 0 - component-wise comparison of design and permissible values;
  - 1 - vertical component in case of reaction with the sign "+" accounts for 50% of the permissible value;
  - 2 - permissible lateral load is a function of the vertical component :  $FH = f(FV)$ . The relations are specified in the form of nomograms. The nomogram number is entered into the field for forces with the negative sign. The nomograms themselves are described in the «Nomograms» spreadsheet;
  - 3 - vertical component in case of reaction with the sign "+" is determined by the value in the MN column;
  - 4 - load-bearing capacity of the support is determined according to the following iteration formula:  $f_n/FN + f_h/FH \leq 1$ ;
  - 5 - assessment of support's load capacity according to NP-068-05, [\[REF 14\]](#): calculated axial forces and SRSS Square Root of Sum Squares of resulting moment are compared with FA and MA values. Applicable only for [SUP](#) and [ANC](#).
  - 6 - Applicable only for [SUP](#) and [ANC](#). Comparison is made for axial and shear forces and torsional/bending moments. Shear Force and Bending Moment are calculated as SRSS from corresponding components. Allowable values should be set in the following order:  $F_A$

$F_S \neq 0$ ,  $M_T \neq 0$ , where:  $F_A$  and  $F_S$  – allowable axial and shear forces;  $M_T$  and  $M_B$  – allowable torsional and bending moments.

7 - assessment is made by interaction method for all load components:  $\sum(|f_i|/F_i) < 1$ .

For supports with different upward and downward loads, the positive vertical component is defined in the field for FA2

8 - Assessment of fix supports on the component by component basis. For supports with different upward and downward loads, the positive vertical component is defined in the field for FN2

9 - Allowable load is set in the field FN1. Comparison with vertical and lateral components of

calculated loads is made by SRSS rule:  $F_N \geq \sqrt{F_X^2 + F_Z^2}$ ; Axial load is limited by the value of  $0.3 \cdot F_N$

10 - Allowable load is set in the field FN1. Comparison with all three components of

calculated loads is made by SRSS rule:  $F_N \geq \sqrt{F_X^2 + F_Y^2 + F_Z^2}$

Name of the Table	Data Type										
	0	1	2	3	4	5	6	7	8	9	10
LISEGA 2010RS	X	X		X	X						
LISEGA2010RSENR2	X			X	X					X	X
OTT 0157-2013								X			
TITAN-2_R1_7	X			X					X		
TITAN-2_R2_SPB_0	X			X					X		X
НП-068-05-AP						X					
НП-068-05-МР3						X					
НП-068-05-П3						X					
ОСТ 24-125-01	X		X								
СПиР-О-2008	X										
СТО 79814898	X	X									
НПАС										X	
Л8	X			X							
CUSTOM	User Defined										

- 2) The coordinate system for the values of permissible loads is determined depending upon the mark of the current record: if the '\$GCS' chain of characters is present in the mark name (case is of no importance), then it is assumed that the loads are specified in the global coordinate system. Otherwise, they are specified in the local coordinate system:

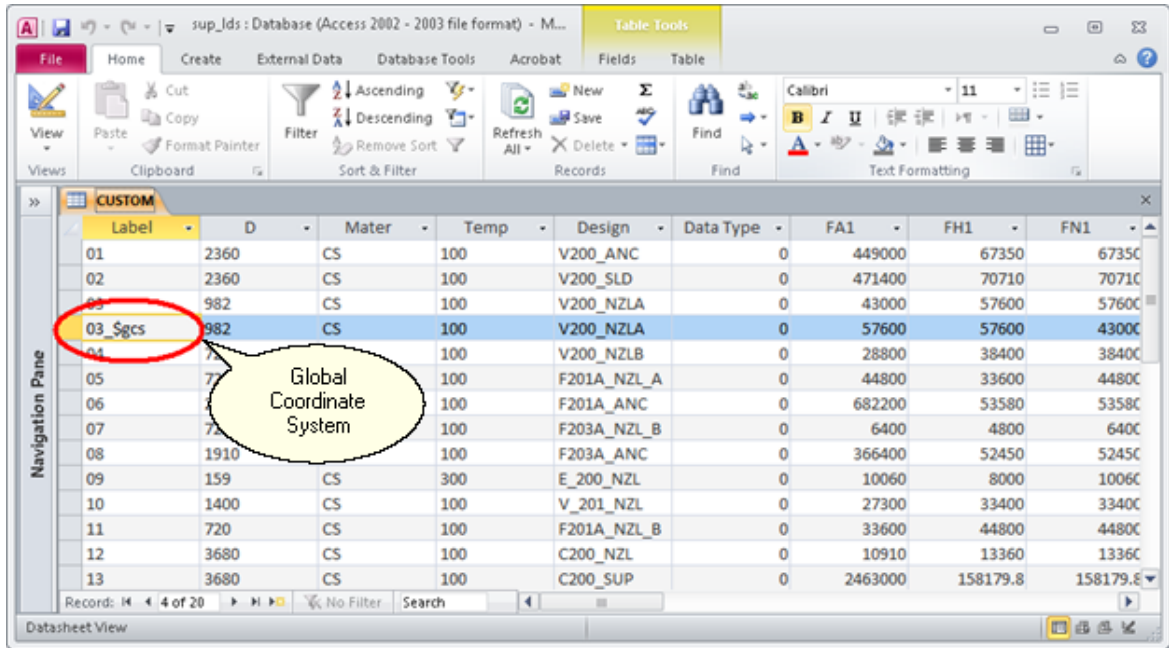

3) When the "View" button of the load selection dialog is pressed, the following dialog will be displayed:

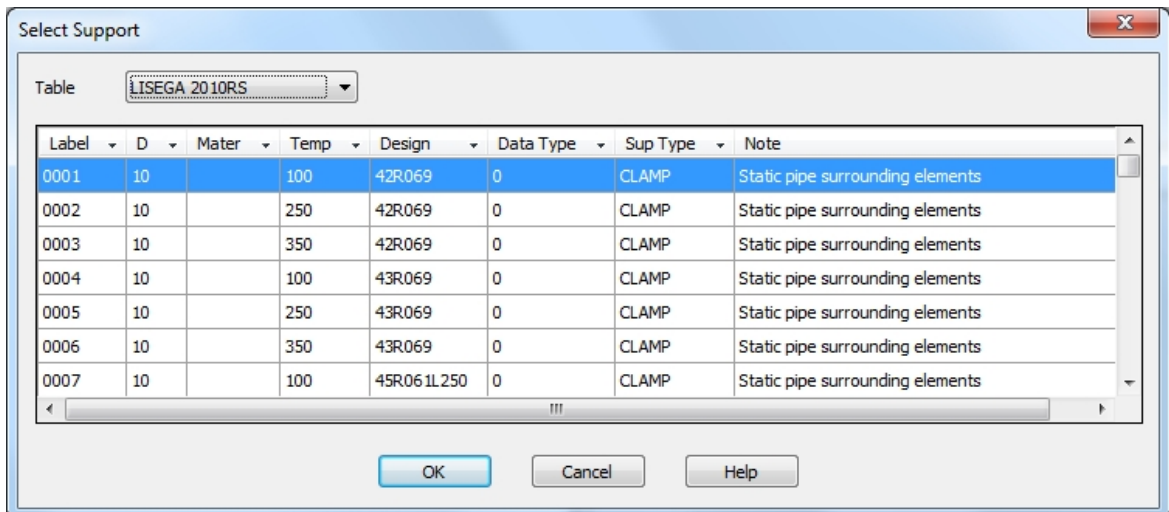

which fields correspond to the values described above. Using integrated filters, one can quickly find the required reference.

4) If the material name contains the character combination "\$T", then for this entry the load correction for the coefficients from the [temperature table](#) is not performed

➤ Tables "LOADS" with amplification factors used for scaling nominal loads depending on load combination and pipe's [seismic category](#) (field LOADS of the [SUPPORTS](#) table)

ID	Label	RUS_TEXT	S_CAT_I	S_CAT_II	S_CAT_III
1	NOC	HYЭ	1	1	1
2	AOO	HHYЭ	1.2	1.2	1.2

4	NOC+OBE	НУЭ+ПЗ	1.2	1.5	0
5	AOO+OBE	ННУЭ+ПЗ	1.2	1.5	0
6	DBA	УПА	1.4	1.4	1.4
7	NOC+SSE	НУЭ+МРЗ	1.4	0	0
8	AOO+SSE	ННУЭ+МРЗ	1.4	0	0
9	DBA+OBE	УПА+ПЗ	1.5	0	0

Note: zero value indicates that the specified load combination is not applicable for corresponding [seismic category](#).

Field name	Data type	Field Size	Description
Label	Short Text	255	Label
RUS_TEXT	Short Text	255	Name to be shown in GUI
S_CAT_I	Number	-	Seismic Category I
S_CAT_II	Number		Seismic Category II
S_CAT_III	Number		Seismic Category III

➤ Tables **Temperature** with correction factors used for scaling nominal loads depending on the piping operational temperature (field TEMPERATURES of the [SUPPORTS](#) table)

ID	MAT_GROUP	Temperature, °C	FS
1	1	50	1
2	1	150	1
3	1	250	0.8
4	2	350	0.7

## 22 Appendix XIII

### CKTI approach for stress analysis of TEEs and Branch Connections in compliance with chapter 5.2 of RD 10-249-98.

Computation of the Stage I effective stresses (item 5.2.6.2.5):

$$\sigma_{\text{эф}} = 0.5\sigma_{\text{np}} + \max(\Omega; 1.0) \frac{k_{\text{п}} \sqrt{M_x^2 + M_y^2 + M_z^2}}{W}$$

Computation of the Stage II effective stresses (item 5.2.6.3.4):

$$\sigma_{\text{эф}} = \sigma_{\text{np}} + \max(0.6\gamma_m; 1.0) \frac{k_{\text{п}} \sqrt{M_x^2 + M_y^2 + M_z^2}}{W}$$

Computation of the Stage III effective stresses (item 5.2.6.4.4):

$$\sigma_{\text{эф}} = 2\sigma_{\text{np}} + \max(\gamma_m; 3.0) \frac{k_{\text{п}} \sqrt{M_x^2 + M_y^2 + M_z^2}}{W}$$

Computation of the Stage IV effective stresses (item 5.2.6.5.4):

$$\sigma_{\text{эф}} = \max(0.6\gamma_m; 1.0) \frac{k_{\text{п}} \sqrt{M_x^2 + M_y^2 + M_z^2}}{W}$$

Calculations according to the above equations are performed for three elements joined in the intersection node (sections 1-1, 2-2 and 3-3 from Figure 5.12, Chapter 5.2, RD 10-249-98)

Equivalent stresses due to pressure ( $\sigma_{\text{np}}$ ) are calculated according to equation (3), item 5.2.6.2.2 RD 10-249-98 with use of the actual element's sizes.

Bending moments  $M_X$ ,  $M_Y$ ,  $M_Z$  acting in the considered sections are determined according to Figure 5.14, Chapter 5.2, RD 10-249-98.

Overload factor  $kn$  is taken according to item 5.2.6.2.4, RD 10-249-98.

Section modulus  $W$  used for sections 1-1 and 2-2 is defined according to the actual dimensions of the TEE body. Section modulus for section 3-3 is defined on the basis of branch dimensions (for extruded and forged tees matched pipe should be used)

Coefficients  $\Omega_{\text{н}}$   $\gamma_m$  are defined depending on location and type of tee joint with use of the following formulas:

Type of Tee joint	Branch (sec. 3-3)	RUN (sec. 1-1 and 2-2)
Branch Connections, unreinforced and reinforced tees.	$\Omega = 0.8 \left(\frac{R}{T}\right)^{0.67} \left(\min\left(\frac{r}{R}; 0.5\right)\right)^{0.5} \left(\frac{t}{T}\right)$	$\Omega = 0.9 \left(\frac{r}{t}\right)^{0.3}$

	$\gamma_m = A \left(\frac{R}{T}\right)^{0.67} \left(\frac{r}{R}\right)^{0.5} \left(\frac{t}{T}\right)^\tau$ $A = \begin{cases} 3.0 & \text{if } (r/R) \leq 0.9 \\ 1.8 & \text{if } (r/R) = 1.0 \end{cases}$	$\gamma_m = A \left(\frac{R}{T}\right)^{0.67} \left(\frac{r}{R}\right)$
	$\Omega = 0.8 \left(\frac{R}{T}\right)^{0.67} \left(\min\left(\frac{r}{R}; 0.5\right)\right)^{0.5} \left(\frac{t}{T}\right)$	$\Omega = 0.9 \left(\frac{r}{t}\right)^{0.3}$
Welded, extruded and forged ( $r_c > 0.1r$ ) tees	$\gamma_m = A \left(\frac{R}{\left(1 + \frac{r_c}{R}\right)T}\right)^{0.67} \left(\frac{r}{R}\right)^{0.5}$ $A = \begin{cases} 3.0 & \text{if } (r/R) \leq 0.9 \\ 1.8 & \text{if } (r/R) = 1.0 \end{cases}$	$\gamma_m = 1.6 \left(\frac{R}{\left(1 + \frac{r_c}{R}\right)T}\right)^{0.67}$

Notes:

1) Designations:

$R$  – RUN mean radius;

$T$  – RUN wall thickness;

$r$  – BRANCH mean radius (for extruded and forged tees dimensions of the matched pipe should be used)

$t$  – BRANCH wall thickness (for extruded and forged tees dimensions of the matched pipe should be used)

$r_c$  – radius of curvature of external contoured portion of outlet

2) Value of A in the range of  $0.9 < (r/R) < 1.0$  is defined by linear interpolation.

3) 
$$\tau = \begin{cases} 0.4 & \text{if } (t/T) < 1 \\ 1.0 & \text{if } (t/T) \geq 1 \end{cases}$$

4) For reinforced tees run thickness T could be substituted by effective value:  $T_C = T + 0.5t_r$ , where  $t_r$  is pad's thickness ( $t_r \leq 1.5T$ ).

## 23 Appendix XIV

### Modeling of the tee/branch connection's joints.

Depending from the [TEE\\_FLEX](#) option dPIPE may analyze tee/branch connection's joints taking into account their local flexibility. To do that dPIPE automatically split existing mesh according to the data for "standard tee" (see command [TEE](#)):

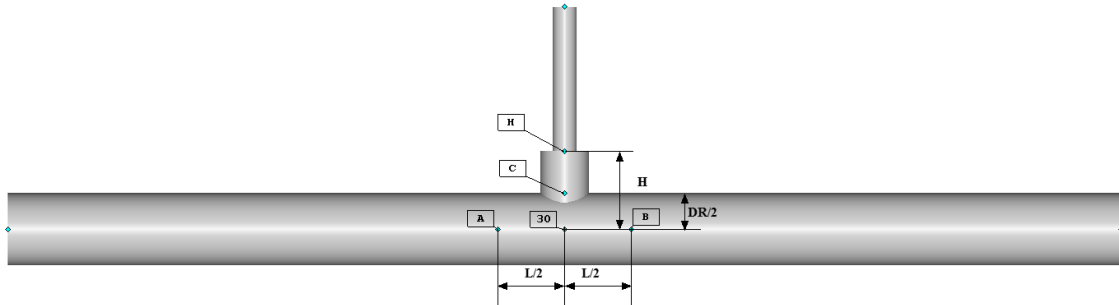

- dPIPE creates weightless element «30 – C» with length equal to the half diameter of the header pipe;
- Flexibility of the joint is located in the point "C" that is intersection of the branch pipe and header's outer surface;
- If the length of the header is set, dPIPE creates two elements: «30-A» and «30-B» with outer diameter = DR and wall thickness = TR. If the weight  $W$  of the fitting is not explicitly defined, these elements inherit weigh per length that was set for header pipe. Otherwise, their weight per length is calculated as  $W/L$ . Insulation weight is defined as  $IWGT = IWGT_{RP} \cdot (DR/OD_{rp})$ , where  $IWGT_{RP}$  and  $OD_{rp}$  are insulation's weigh per length and outer diameter of the header pipe.
- If the height  $H$  of the branch is set, dPIPE creates element "C-H":  $OD = DB$ ,  $t = TB$ ,  $mat = MAT$ . If the weight  $W$  of the fitting is not explicitly defined, this element inherits weigh per length from the branch pipe. If the length of the header  $L$  is set, element "C-H" is weightless ( $w = 0$ ), else:  $w = W/(H-DR/2)$ . Insulation's weigh per length in this case is taken from the branch pipe:  $IWGT = IWGT_{BP}$

## 24 Appendix XV

### Appendix XV. Engineering methodology for seismic assessment of small bore pipes (SBP).

Dividing the seismic load into two parts is an accepted approach for piping seismic analysis:

- primary loads due to inertia. When corresponding stresses are calculated these loads are combined with other sustained loads, such as weight loads and internal pressure;
- secondary loads due to seismic anchor movements (SAM).

The presented methodology is aimed to reduce the conservatism of the seismic analyses for small bore pipes when they are considering in one complex model together with big size pipes. The seismic load acting on the small bore pipes is transmitted both: via their supporting system and through the big pipes to which small bore pipes are connected. Seismic stresses in this case are calculated on the base of internal loads derived from the combination of inertial and SAM loads. The last ones in this case may be considered as loads from the motion of big size pipes.

To avoid this effect, the following sequence of steps is proposed as a part of the dPIPE calculations:

1. Select piping segments that may be classified as “small bore pipes” with help of the decoupling criteria. One of such criteria proposed in the literature is the ratio of run to branch pipe moment of inertia [REF 18]:

$$R_{SBP} = \frac{I_{RUN}}{I_{BRANCH}} > 25$$

- How to manage that in dPIPE:

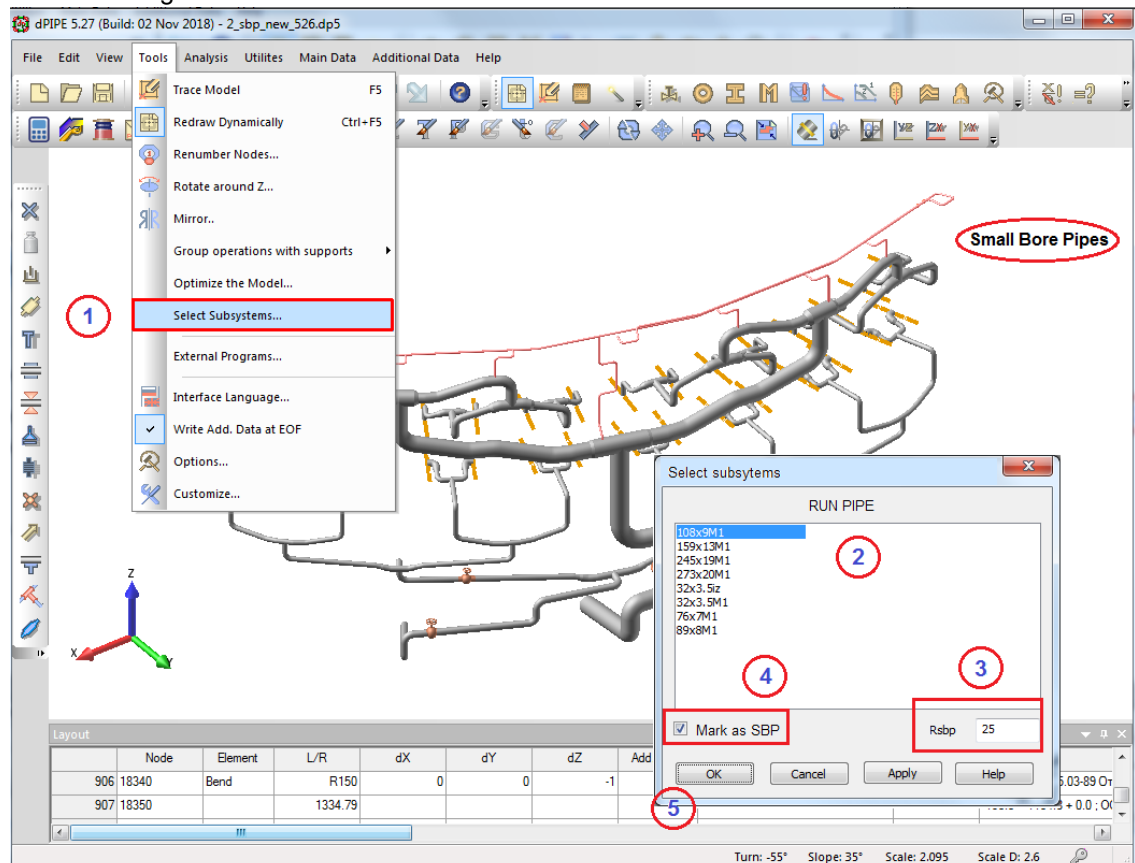

2. Run conventional seismic analysis of the whole system. Resulting internal forces in the small bore pipes would consist from the combination of the primary (inertial) seismic loads,  $F_{SBP}^{INRT}$ , and secondary (displacement based) components,  $F_{SBP}^{SAM}$ :

$$F_{SBP}^{(1)} = F_{SBP}^{INRT} + F_{SBP}^{SAM}$$

Under this analysis corresponding seismic equations are checked only for big pipes

3. Set to zero weight of small bore pipes segments and run the seismic analysis again. Now inertial seismic loads are excluded for small pipes and only secondary loads coming from the seismic motion of the big pipes are applied:

$$F_{SBP}^{(2)} = F_{SBP}^{SAM}$$

Results of this analysis are used for the check of stress equations that consider *secondary loads for small bore pipes* (like EQ. 10 of ASME NC-3600)

4. Create load combination:

$$F_{SBP}^{(3)} = F_{SBP}^{(1)} - F_{SBP}^{(2)} = F_{SBP}^{INRT}$$

These loads are used for the check of *seismic stresses for the small bore pipes*

## 25 Appendix XVI

### Appendix XVI. Export of results of calculations from dPIPE to LICAD

- The export of pipe supports loads from dPIPE to LICAD<sup>®</sup> is carried out depending on the [LCD\\_VER](#) parameter both for the “classic” version “LICAD-10” and for the version adapted for Russian Standards - “LICAD-RS-EN”
- For the “LICAD-RS-EN” version, the following types of loads and their combinations are available:

Loads Combination	Designation ( <a href="#">TYPE</a> )	<a href="#">piping seismic category</a>		
		I	II	III
Cold	COLD	1	1	1
Hot	HOT			
<a href="#">NOC</a>	NE	1	1	1
<a href="#">Abnorm.</a>	NNE	1.2	1.2	1.2
<a href="#">LOCA</a>	UPA	1.4	1.4	1.4
<a href="#">HTEST</a>	HTEST	1	1	1
<a href="#">NOC+OBE</a>	NE_PZ	1.2	1.5	1.5
<a href="#">Abnorm+OBE</a>	NNE_PZ	1.2	1.5	-
<a href="#">FAULT+OBE</a>	UPA_PZ	1.5	-	-
<a href="#">NOC+SSE</a>	NE_MRZ	1.4	-	-
<a href="#">Abnorm+SSE</a>	NNE_MRZ	1.4	-	-

- For the “LICAD-10” the following loads combination and designations are applicable:

Loads Combination	Designation ( <a href="#">TYPE</a> )
Cold	COLD
Hot	HOT

Service Level A/B loads	Level_AB
Service Level C loads	Level_C
Service Level D loads	Level_D
Testing	TEST

Responsibility for assigning SF coefficients is after the USER: these coefficients are selected according to Code used for analysis

4. The types of loads “COLD” and “HOT” should correspond to those Load Cases from dPIPE that were used for the spring hangers design. These references are mandatory for the models with spring hangers/supports
5. Upon successful completion of the calculations, two files are created in the working folder:
  - file.lrs.csv is an Excel file (csv). To enter into LICAD, it must be saved in xls format.
  - file.lrs\_log.csv is an Excel file (csv) with error messages and notes.
6. The loads on the supports/hangers are exported in kN, displacements and linear dimensions are given in mm
7. The table below presents correspondence between dPIPE types of the Supports/Hangers and LICAD designations

<b>Supports in dPIPE</b>	<b>LICAD Configuration</b>
Spring hanger on the horizontal run of the pipe	S13 (one chain) S02 (two chains)
Spring hanger on the riser	S32 (two chains)
Spring support on the horizontal run of the pipe	S29 (one chain)
Rigid hanger on the horizontal run of the pipe	S45 (one chain) S40 (two chains)
Rod hanger on the riser	S52 (two chains)
Fix Support	S30/FP
One-way restraint	S30
Linear Restraint	S30/G2P
Guide support	S30/40GS (OD < 32 mm) S30/49GS (OD ≥ 32 mm)
Rigid Strut	Y01
Snubber	Y02

8. The coordinate system used for fixed and guide supports come from LICAD:

- the x axis lies in a horizontal plane and is perpendicular to the axis of the pipe;
- the y axis is directed along the pipe axis;
- the z axis is directed upwards and perpendicular to the x and y axes

Accordingly, the following loads are exported to LICAD:

- Fx – lateral load;
- Fy – axial load;
- Fz(+) – vertical load (tension);
- Fz(-) – vertical load (compression);

LICAD does not provide instructions on how to interpret the loads if support is located on the vertical run of the pipe. In this case converter exporting loads makes them symmetrical:

$$F_x = F_z(+) = F_z(-) = \text{MAX}\{ |F_x|; |F_z| \}.$$

If the support sustains the maximal load, it can be oriented around the axis of the pipe in any direction. If it fails, then (knowing the orientation), one can try to set the load manually. More strong supports are not selecting since for each diameter there is only one 49FP/GS support (LICAD-RS-EN) for each diameter.

## 26 Appendix XVII

### Appendix XVII. The procedure for calculating of fatigue curves according to GOST R 59115.9-2021[REF 24] in the dPIPE program

The allowable amplitude of the elastically calculated stress or the allowable number of cycles at  $[N_0] \leq 10^{12}$  is calculated by the formulas, considering the maximum influence of the cycle asymmetry (clause 10.12):

$$[\sigma_{aF}] = \frac{E^T e_c^T}{(4n_N [N_0])^m} + \frac{R_c^T - R_{p0,2}^T}{(4n_N [N_0])^{m_s} - 1}$$

$$[\sigma_{aF}] = \frac{E^T e_c^T}{n_c (4[N_0])^m} + \frac{R_c^T - R_{p0,2}^T}{n_c ((4[N_0])^{m_s} - 1)}$$

The smallest value from  $[\sigma_{aF}]$  or  $[N_0]$  is taken for the consequent analyses. The parameters included in the above formulas are determined in accordance with clause 10.8 only for the case:

$$R_m^T \leq 700 \text{ MPa}; n_\sigma = 2; n_N = 10; R_c^T = R_m^T (1 + 0.014Z^T);$$

$$e_c^T = 1.151 \lg \left( \frac{100}{100 - Z_c^T} \right) - 0.025$$

$$Z_c^T = \min \{ Z^T; 50\% \} \quad (Z^T \text{ according to GOST R 59115.3})$$

$$m = 0.5 \quad \text{npu } R_m^T \leq 700 \text{ MPa}$$

$$m = 0.36 + 0.0002 R_m^T \quad \text{npu } 700 < R_m^T \leq 1200 \text{ MPa}$$

$$m_e = 0.132 \lg \left[ \frac{R_m^T}{R_{-1}^T} (1 + 0.014 Z^T) \right]$$

$$R_{-1}^T = 0.4 R_m^T \quad \text{if } R_m^T \leq 700 \text{ MPa}$$

$$R_{-1}^T = (0.54 - 0.0002 R_m^T) R_m^T \quad \text{if } 700 < R_m^T \leq 1200 \text{ MPa}$$

Data for  $E^T$ ,  $Z^T$ ,  $R_m^T$  is taken equal to the smallest values found in the range of operating temperatures for the considered cycle. The value of  $R_{p0,2}^{T \min}$  is determined at the minimum temperature of the cycle.

$E^T$  - Elastic Modulus, MPa;

$R_m^T$  - minimal value of the tensile strength, MPa;

$R_{p0,2}^T$  - minimal value of the yield strength, MPa;

$Z^T$  - reduction of area, %.

### Fatigue Evaluation including Environmental Effects

- 1) Influence of the water medium on the fatigue has to be considered if the temperature of water  $T > 150^\circ\text{C}$ . There is a gap between the curve in air and in water, since  $F_{pn} \approx 2$  at  $T = 150^\circ\text{C}$ .

#### Limitations of the methodology:

- water medium:  $T \leq 350^\circ\text{C}$ ;
  - number of cycles:  $[N_0] \leq 10^{12}$ .
- 2) Allowable stress amplitude  $[\sigma_{aF}]$  that corresponds to number of cycles  $N_0$  or allowable number of cycles  $[N_0]$  corresponded to  $(\sigma_{aF})$  is taken as minimum between two values calculated in assumption of the maximal influence of the cycle's asymmetry (clauses B.4 and B.9):

$$[\sigma_{aF}] = \frac{E^T e_c^{20}}{(4n_N F_{pn} [N_0])^{0,5}} + \frac{R_{cF}^T - R_{p0,2}^{T_{\min}}}{(4n_N [N_0])^{m_{eF}} - 1}$$

$$[\sigma_{aF}] = \frac{E^T e_c^{20}}{n_\sigma (4F_{pn} [N_0])^{0,5}} + \frac{R_{cF}^T - R_{p0,2}^{T_{\min}}}{n_\sigma ((4[N_0])^{m_{eF}} - 1)}$$

where:

$$n_\sigma = 2 ; n_N = 10$$

$$e_c^T = 1.15 \lg \left( \frac{100}{100 - Z_c^{20}} \right) - 0.025$$

$$Z_c^{20} = \min \{ Z^{20} ; 50\% \}$$

$$R_{cF}^T = R_m^{20} (1 + 0.014 Z_F)$$

$$m_{eF} = 0.132 \lg [ 2.5 (1 + 0.014 Z_F) ]$$

$$Z_F = 100 - \frac{100}{\exp \left( 2e_c^{20} / \sqrt{F_{pn}} \right)}$$

The coefficient  $F_{pn}$  is conservatively calculated according to clause B.8 depending on the temperature of the metal  $T$ , the sulfur content in the metal  $S$ , the oxygen concentration in the water  $O$  and the strain rate  $\dot{\epsilon}$

- for carbon steels:

$$F_{pn} = \exp \left( 0.632 - 0.101 \cdot S^* \cdot T^* \cdot O^* \cdot \dot{\epsilon}^* \right)$$

- for alloyed chromium-molybdenum and chromium-molybdenum-vanadium steels:

$$F_{pm} = \exp(0.702 - 0.101 \cdot S^* \cdot T^* \cdot O^* \cdot \dot{\varepsilon}^*)$$

$$S^* = 0.015 \text{ (conservatively taken as } S > 0.015\%)$$

$$T^* = T - 150 \text{ ( } T \text{ - maximal temperature of the cycle, } ^\circ\text{C)}$$

$$O^* = 0 \quad \text{if } KO \leq 0.04 \text{ mg/kg}$$

$$O^* = \ln\left(\frac{KO}{0.04}\right) \quad \text{if } 0.04 < KO \leq 0.5 \text{ mg/kg}$$

$$O^* = \ln(12.5) \quad \text{if } KO > 0.5 \text{ mg/kg}$$

$$\dot{\varepsilon}^* = \ln(0.001) \text{ (conservatively taken as } \dot{\varepsilon} \leq 0.001\% \text{sec}^{-1})$$

- for austenitic steels:

$$F_{pm} = \exp(0.734 - T^* \cdot O^* \cdot \dot{\varepsilon}^*)$$

$$T^* = \min\left\{\frac{T-150}{175}; 1\right\} \text{ ( } T \text{ - maximal temperature of the cycle, } ^\circ\text{C)}$$

$$O^* = 0.281 \text{ (for all values of } KO)$$

$$\dot{\varepsilon}^* = \ln(0.001) \text{ (conservatively taken as } \dot{\varepsilon} \leq 0.0004\% \text{sec}^{-1})$$

In accordance with clause B.13, the allowable number of cycles must be taken as the smallest of those determined in air according to 10.12 and in water according to B.4-B.8 (***the curves in air and in water are not consistent with each other: the number of allowable cycles in water can be more than in air***).

- 3) The allowable stress amplitude for the number of cycles  $N_0$  or the allowable number of cycles for a given stress amplitude ( $\sigma_{aF}$ ) for a welded joint is defined as (clause B.12):

$$[\sigma_{aF}]_s = \min\left\{\varphi_s [\sigma_{aF}]^*; [\sigma_{aF}]\right\}$$

$$[N_0]_s = \min\left\{[N_0]^*; [N_0]\right\}$$

where:

$[\sigma_{aF}]^*$  - allowable stress amplitude on air;

$[N_0]^*$  - allowable number of cycles on air, calculated for stress amplitude ( $\sigma_{aF}$ )<sub>s</sub>  
 $= (\sigma_{aF})/\varphi_s$ .

## 27 Appendix XVIII

### Appendix XVIII. Criteria for postulated rupture locations of HE piping adopted for different Codes

#### 1. ASME BPVC NB-3600 (Class 1 Nuclear Piping)

Locations of ruptures of Class 1 piping are determined by checking the following inequalities (exceeding the value of  $2.4 S_m$  corresponds to a rupture,  $1.2 S_m$  - to a crack):

Equation (10), NB-3653.1:

$$S_n = C_1 \frac{P_0 D_0}{2t} + C_2 \frac{D_0}{2I} M_i^{(10)} + C_3 E_{ab} \times |\alpha_a T_a - \alpha_b T_b| > \begin{cases} 2.4 S_m \\ 1.2 S_m \end{cases}$$

Equation (12) and (13), NB-3653.6:

$$S_e = C_2 \frac{D_0}{2I} M_i^{(12)} > \begin{cases} 2.4 S_m \\ 1.2 S_m \end{cases}$$

$$S = C_1 \frac{P_0 D_0}{2t} + C_2 \frac{D_0}{2I} M_i^{(13)} + C_3 E_{ab} \times |\alpha_a T_a - \alpha_b T_b| > \begin{cases} 2.4 S_m \\ 1.2 S_m \end{cases}$$

where:

$S_n$ ,  $S_e$ ,  $S$  are stress ranges calculated according to equations (10) – (13);

$C_1$ ,  $C_2$ ,  $C_3$ ,  $C_3'$  are secondary stress indices for the specific component under investigation (NB-3680);

$P_0$  is range of service pressure;

$D_0$  is outside diameter of pipe;

$t$  is nominal wall thickness of product;

$I$  is moment of inertia;

$M_i^{(10)}$  is resultant range of moment that occurs when the system goes from one service load set to another. Service loads and combinations are provided in the Design Specification. In the combination of moments from load sets, all directional moment components in the same direction shall be combined before determining the resultant moment. If the method of analysis is such that only magnitudes without relative algebraic signs are obtained, the most conservative combination shall be assumed;

$M_i^{(12)}$  is same as  $M_i^{(10)}$  for the pair of load sets under review except it includes only moments due to thermal expansion and thermal anchor movements;

$M_i^{(13)}$  is same as  $M_i^{(10)}$  for the pair of load sets under review except it excludes the moments due to thermal expansion and thermal anchor movements;

$T_a$ ,  $T_b$ ,  $\alpha_a$ ,  $\alpha_b$  are range of average temperature and coefficients of thermal expansion on side a(b) of gross structural discontinuity or material discontinuity;

$E_{ab}$  is average modulus of elasticity of the two sides of a gross structural discontinuity or material discontinuity at room temperature;

$S_m$  – is average of the allowable stress intensity value for the highest and the lowest temperatures of the metal during the transient.

Additional criteria for Class 1 piping ruptures is the value of the Cumulated Usage Factor U. The break is postulated if this value exceeds 0.1. However, this value can be taken as 0.4 when the effects of environmental assisted fatigue (EAF) are considered in the piping design.

## 2. ASME BPVC NCD-3600 (Class 2 and 3 Nuclear Piping)

Locations of ruptures are determined by checking the following inequalities (0.8 - break; 0.4 - crack):

$$S_{OL} + S_E > \begin{cases} 0.8(1.8S_h + S_a) \\ 0.4(1.8S_h + S_a) \end{cases}$$

$$S_a = f(1.25S_c + 0.25S_h)$$

where:

$S_{OL}$  are stresses due to pressure, weight, and occasional loads for OBE level (NCD-3653, Equation 9)

$S_E$  are thermal expansion stresses (NCD-3653.2, Equation 10)

$S_a$  is allowable stress range for expansion stresses;

$S_c$  is basic material allowable stress at minimum (cold) temperature;

$S_h$  is basic material allowable stress at maximum (hot) temperature;

$f$  is stress range reduction factor for cyclic conditions, is defined according to Table NC-3611.2(e)-1.

## 3. Adaptation of the Methodology for Postulated Rupture Locations in High Energy Lines to the PNAE Code

For calculation of the High Energy Lines according to the PNAE Code, [REF1], it is suggested to use methodology similar to the one used for rupture locations of ASME Class 1 piping according to ASME NB, [REF3]

For this purpose, the additional stresses are defined:

- $\sigma_{RK}'$  - stress range calculated by formulas of item 2.3.2, Appendix 5 of PNAE Code, from the moments due to thermal expansion and thermal anchor movements. These stresses are analogue of Equation (12) of ASME NB-3600;
- $\sigma_{RK}''$  - is stress range calculated by formulas of item 2.3.2, Appendix 5 of PNAE Code, except it excludes from the loading moments due to thermal expansion and thermal anchor movements. Additionally, these stresses include membrane temperature stresses due to gross structural or material discontinuity. These stresses are analogue of Equation (13) of ASME NB-3600

Intermediate locations of piping ruptures are postulated based on the following piping stress and fatigue analysis criteria:

- the circumferential or longitudinal break is postulated if:

$$\sigma'_{RK} > 0.8 \times 2R_{p0.2}^T = 1.6R_{p0.2}^T$$

or

$$\sigma''_{RK} > 0.8 \times 2R_{p0.2}^T = 1.6R_{p0.2}^T$$

In addition to these equations, to locate the postulated break, the value of the cumulated fatigue usage factor U is checked:

$$U > 0.1$$

However, when the effects of environmental assisted fatigue are considered in the piping design then instead of  $U > 0.16$  the following condition may be applied:

$$U > 0.4$$

- The throw-wall crack is postulated if:

$$\sigma'_{RK} > 0.4 \times 2R_{p0.2}^T = 0.8R_{p0.2}^T$$

or:

$$\sigma''_{RK} > 0.4 \times 2R_{p0.2}^T = 0.8R_{p0.2}^T$$

#### 4. Adaptation of the Methodology for Postulated Rupture Locations in High Energy Lines to the EN 13480 Code

For calculation of the High Energy Lines according to the EN, [REF10], it is suggested to use methodology similar to the one used for rupture locations of ASME Class 2 piping according to ASME NC

Intermediate locations of piping ruptures are postulated based on the following piping stress and fatigue analysis criteria:

- the circumferential or longitudinal break is postulated if:

$$\sigma_2 + \sigma_3 > 0.8 \times (1.2f_f + f_a)$$

- the throw-wall crack is postulated if:

$$\sigma_2 + \sigma_3 > 0.4 \times (1.2f_f + f_a)$$

Sample of analysis specification for Codes PNAE and ASME NB:

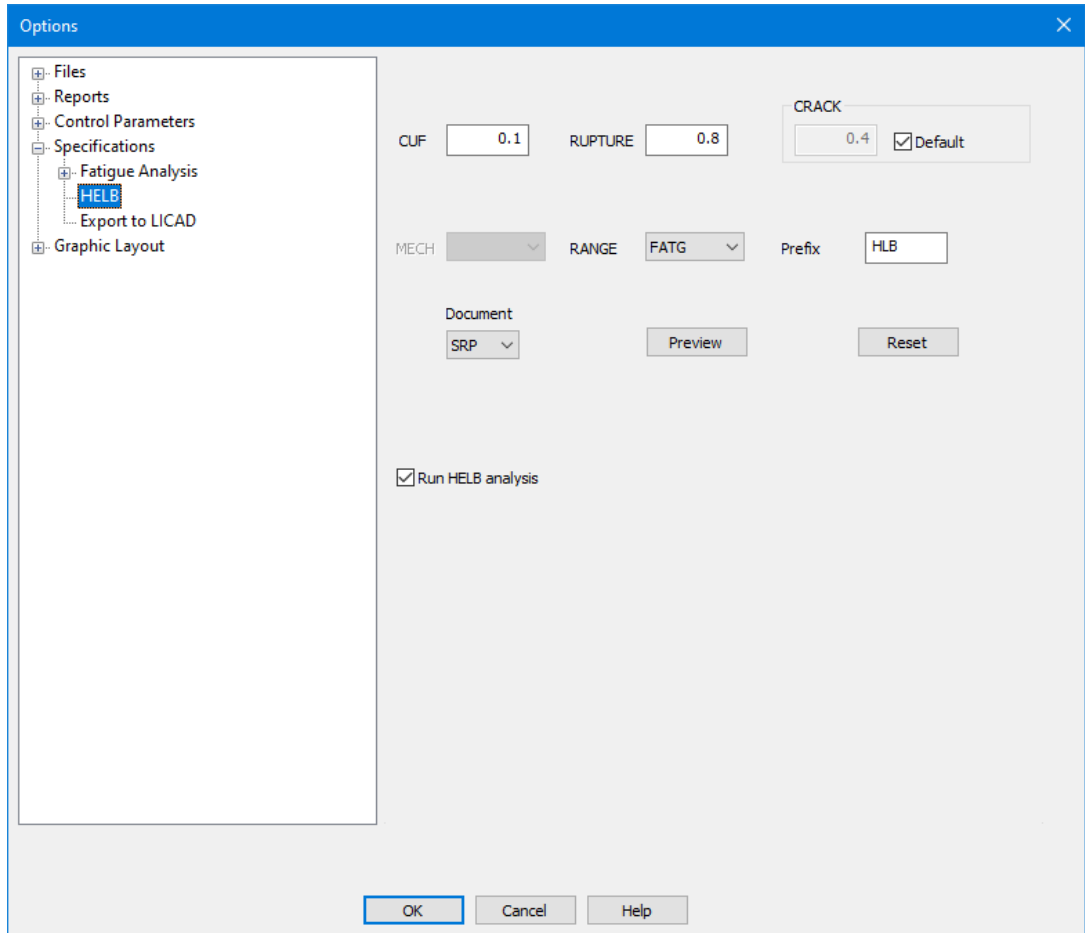

POST HELB `cuf = 0.1, rupture = 0.8, range_ls = 'fatg',`

Sample of analysis specification for Codes EN and ASME NC:

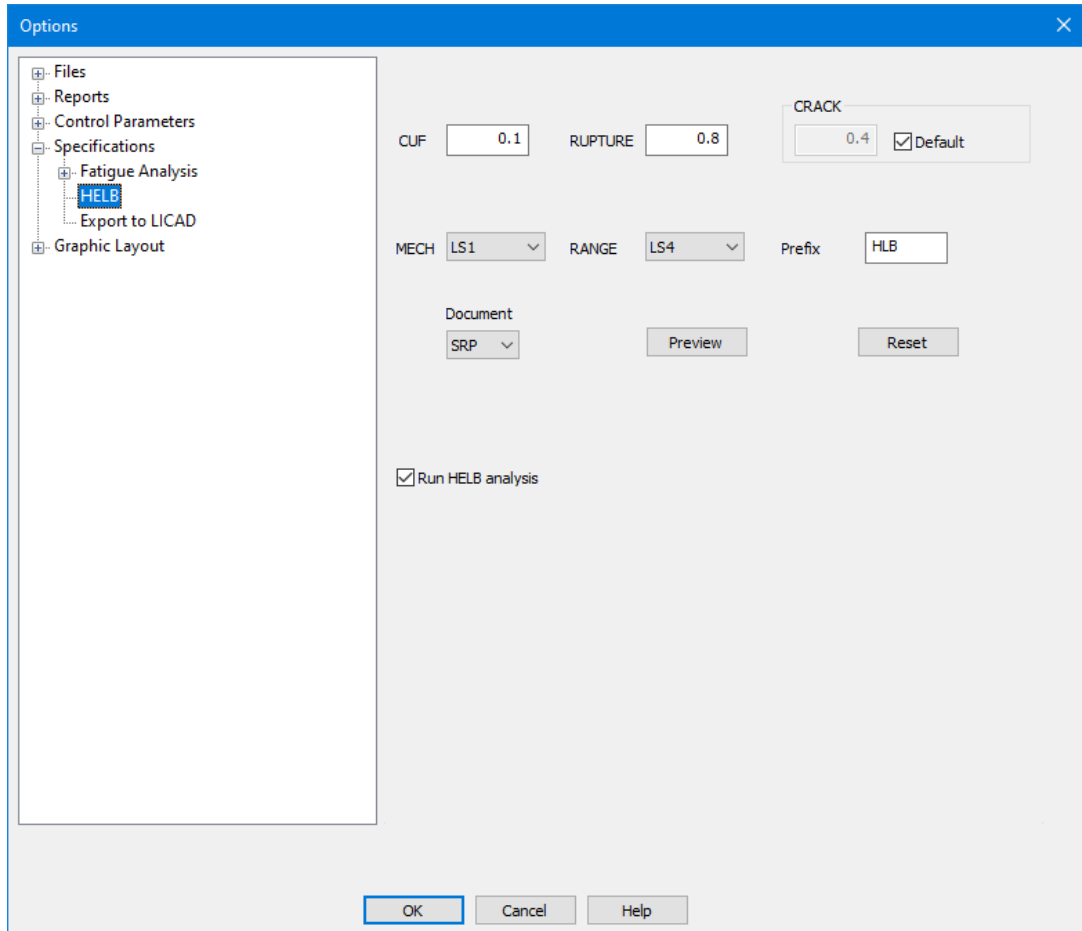

POST HELB cuf = 0.1, rupture = 0.8, mech\_ls = 'LS1', r

## 28 Appendix XIX

### Notes on Modeling Mitered Bends

#### Definitions:

$\alpha$	- total bend angle
$N_c$	- Number of miter joints
$\theta = \alpha / (2 * N_c)$	- Angle between mitered sections
$r$	- Mean pipe radius
$R_0 = (s * \cot \theta) / 2$	- Equivalent radius of the mitered bend (geometrically defined, corresponds to the value given in drawings)
$R_{eff} = r * (1 + \cot \theta) / 2$	- Effective radius of the mitered bend (empirical formula proposed by Markl for a single miter joint)

#### Mitered Bends in ASME B31.X and EN 13480 Standards.

1) *Closely spaced miter bend*. Applies to bends where:  $s < r(1 + \tan \theta)$  or  $R_0 < R_{eff}$ .

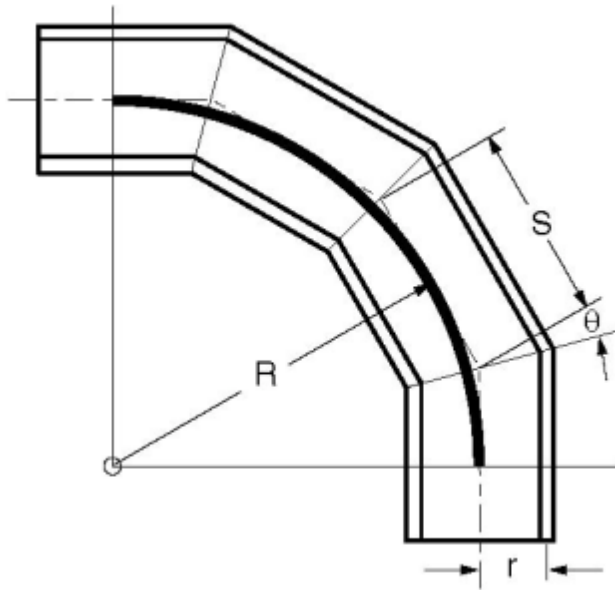

Such bends are modeled as a single BEND element with  $R = R_0$ . Flexibility and stress intensification factors (SIFs) are calculated based on  $R = R_0$ .

2) **Widely spaced miter bend.** Applies to bends where:  $s \geq r(1 + \tan \theta)$  (или  $R_0 \geq R_{eff}$ )

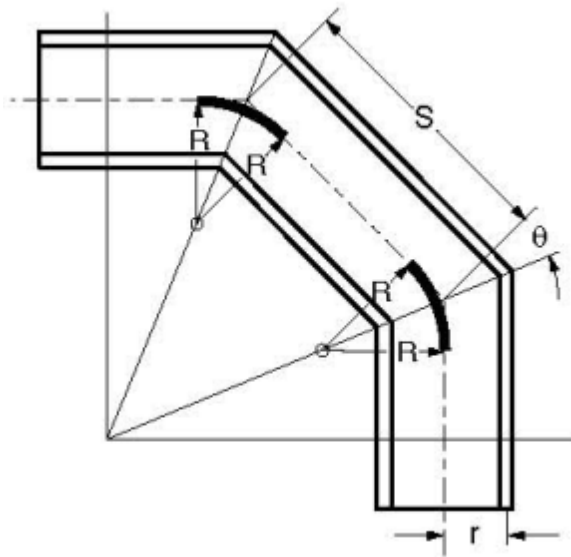

These bends must be modeled as a series of PIPE & BEND elements with  $R = R_{eff}$  (each joint is modeled separately).

Flexibility and SIFs are calculated based on  $R = R_{eff}$ .

This also includes single miter bends (where no intermediate section exists, and  $R_0$  is geometrically undefined)

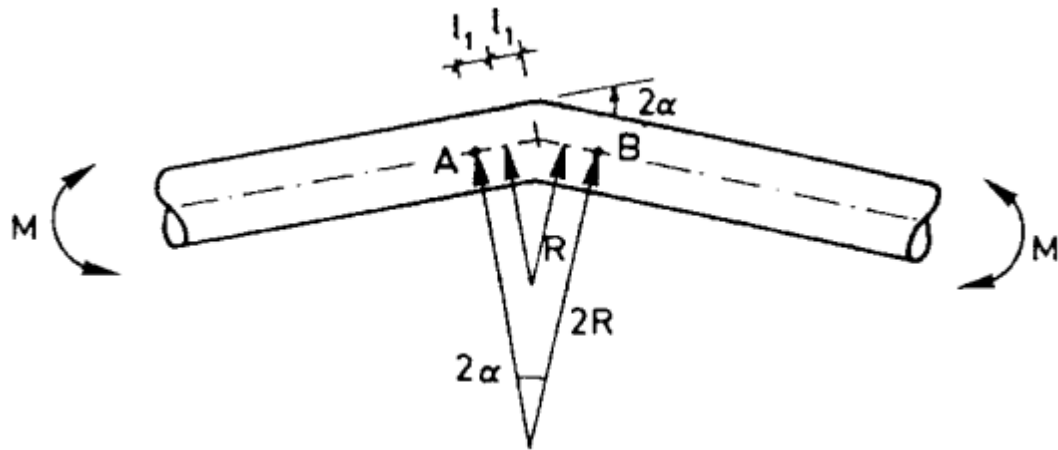

### Note on Russian Standards (PNAE, RTM, RD):

- There are no explicit formulas for mitered bends in PNAE.
- RTM and RD treat mitered bends as smooth bends with radius  $R_0$ , without distinguishing between closely/widely spaced cases.
- Approximately half of the mitered bends per existing OST and STO standards fall under widely spaced ( $R = R_0 > R_{eff}$ ).
- For angles  $\alpha = 15^\circ$  and  $30^\circ$ , single-miter bends are sometimes used.
- End sections are always longer than  $R \cdot \tan \theta$ , meaning all bends have straight end segments (which may differ from the connecting pipe dimensions).

It should be noted:

- 1) For single-miter bends, standards often specify arbitrary fictitious radii  $R$ , which may be greater or less than  $R_{eff}$ . Using  $R_{eff}$  may cause misalignment with the pipeline route.
- 2) To strictly follow to the western standards (e.g., ASME, EN) for modeling of the widely spaced bends, a specialized “constructors” in dPIPE must generate a sequence of PIPE & BEND elements.

### Remarks on Flexibility and Stresses for Widely Spaced Miter Bends.

Analysis shows that if widely spaced bends would be modeled as a single curved element using the drawing-specified radius, deviations from the normative approach can reach: 6% in flexibility and up to 65% in stresses. These discrepancies can be mitigated using equivalent flexibility factors and stress intensification factors (SIFs).

If the miter joint per Code will be modeled as a curved element with  $R = R_{eff}$  its flexibility will be proportional to the length:  $l(R_{eff}) = k_{eff} R_{eff} \alpha$  (where  $k_{eff}$  is the flexibility factor for  $R_{eff}$ )

If using a drawing-specified radius  $R < R_{eff}$ , the equivalent length becomes:  $l(R) = kR\alpha + 2(R_{eff} - R)\tan \theta$ . The second term accounts for additional flexibility from straight sections. Equating these lengths yields the equivalent flexibility factor  $k$  for radius  $R$ :

$$k = k_{eff} \frac{R_{eff}}{R} - 2 \left( \frac{R_{eff}}{R} - 1 \right) \frac{\tan \theta}{\alpha}$$

The same formula applies for  $R > R_{eff}$

$$l(R_{eff}) = k_{eff} R_{eff} \alpha + 2(R - R_{eff}) \tan \theta$$

$$l(R) = kR\alpha$$

$$k = k_{eff} \frac{R_{eff}}{R} + 2 \left( 1 - \frac{R_{eff}}{R} \right) \frac{\tan \theta}{\alpha}$$

A similar formula can be derived for a widely spaced miter bend, for the case of modeling it with one curved element with a radius  $R_0 > R_{eff}$ :

$$k = k_{eff} \frac{R_{eff}}{R_0} + 2N_c \left( 1 - \frac{R_{eff}}{R_0} \right) \frac{\tan \theta}{\alpha}$$

Regarding Stress Intensification Factors (SIFs): SIFs should always be calculated based on  $R_{eff}$ . This approach may be slightly more conservative than ASME requirements since SIFs apply to the entire bend rather than just curved segments.

### Modeling Mitered Bends in dPIPE.

In dPIPE, mitered bends are modeled as a single curved element with equivalent radius  $R_0$ . For single-miter bends (where  $R_0$  is undefined), the radius specified in the technical documentation is used.

For widely spaced miter bends (per B31.1, NC-3600, EN 13480), the following adjustments are made: flexibility factors are corrected as described above and SIFs are calculated using  $R_{eff}$

For Russian standards (RD, PNAE), this procedure is only applied to single-miter bends.

When calculating stresses in pipe bends according to PNAE, a "toroidal" coefficient B is used (indicates how many times the stresses in the bend from pressure are greater than in a straight pipe):

$$B = \frac{2R - r}{2(R - r)}$$

When calculating stresses in a single-miter bend, the effective radius  $R_{eff} = r(1 + \cot(\theta))/2$  is used as the radius, which leads to division by zero for an angle of  $\theta = 45^\circ$  ( $\alpha = 90^\circ$ )

*Note. Formally, according to PNAE and RD, sector bends with an angle  $\theta > 15^\circ$  are not permitted.*

In this case, an alternative formula for the coefficient  $B$  can be taken from B31.3 [[REF 8](#)], which, after several transformations, is written as follows:

$$B' = 1 + 0.643 \tan \theta \sqrt{r/t} \quad \text{if } \theta \leq 22.5^\circ$$

$$B' = 1 + 1.25 \tan \theta \sqrt{r/t} \quad \text{if } \theta > 22.5^\circ$$

The coefficient  $B'$  calculated by these formulas always turns out to be greater than  $B$ .

## References

1. Markl, A.R.C. Fatigue Tests of Piping Components. Trans of A.S.M.E. pp 287-303, April 1952.
2. Rodabaugh, E.C. Review of Data on Mitre Joints in Piping to Establish Maximum Angularity for Fabrication of Girth Butt Welds. WRC Bulletin 208, Aug. 1975.
3. Gresnigt, A.M. Elastic and Plastic Design of Mitred Bends. Proc. 12th Int. Offshore and Polar Engineering Conf., Kitakyushu, Japan, May 26-31, 2002.

## 29 Appendix XX

### Additional parameters of "standard" tees

Обозначения:

Type of TEE	Description
<b>WLT</b>	Welding tee per ASME B16.9
<b>RFT</b>	Reinforced fabricated tee
<b>UFT</b>	Unreinforced fabricated tee
<b>BRC</b>	Branch connection
<b>EXT</b>	Extruded outlet
<b>WOL</b>	Branch welded-on fitting/Weldolet
<b>SOL</b>	Welded-in contour insert/Sweepolet
<b>FWB</b>	Fillet welded and partial penetration welded branch connections

ASME, EN Codes:

- R2 – transition radius of branch reinforcement, mm;
- RP - outside radius of branch reinforcement, mm;

RX - external crotch radius of welded-in contour inserts and welding tees, mm;  
 TA – mean thickness of the header pipe;  
 TC - crotch thickness of welded-in contour inserts and welding tees, mm;  
 TN - nominal wall thickness of branch pipe, mm;  
 TP - reinforcement pad or saddle thickness, mm

PNAE, RD Codes:

TW - reinforcement pad or saddle thickness, mm;  
 CR - mill tolerance of the header pipe;  
 CB - mill tolerance of the branch pipe;  
 KIS – stress index (PNAE)

With the [TEE\\_FLEX](#)='PRG' option, local flexibility is calculated in the following types of tee connections:

Type	RX	TC	TN	TP
<a href="#">BRC</a>			F	
<a href="#">UFT</a>			F	
<a href="#">RFT</a>				F
<a href="#">WLT</a>	F	F		
<a href="#">FWB</a>			F	

If [TEE\\_FLEX](#)='NB', then local flexibility is calculated only in branch connections ([BRC](#)) and welding tees ([WLT](#))

Below is a set of tables indicating the types of standard tees and the parameters used by the program to calculate stresses (**S**) and/or local flexibilities of tee connections (F). The tables are generated for the corresponding Codes. The year of the Code edition is indicated in brackets.

Если [TEE\\_FLEX](#)='NB', то локальная податливость рассчитывается только в штуцерных соединениях ([BRC](#)) и штампованных тройниках ([WLT](#))

PNAE, GOST-59111-A

Type	Flex	TW	CR	KIS
-	-	S	S	S

RD

Type	Flex	CR	CB
-	-	S	S

При включенной опции [TEE\\_FLEX](#)='PRG' локальная податливость для этих Норм учитывается только для тройниковых соединений типа [BRC](#), [UFT](#), [RFT](#).

При включенной опции [TEE\\_RD](#) = 'СКТИ' используются следующие параметры:

RD ([TEE\\_RD](#) = 'СКТИ')

Type	Flex	RX	TN	TP	CR	CB
?	n/a				S	S
<a href="#">WLT</a>	n/a	S			S	S
<a href="#">EXI</a>	n/a	S			S	S
<a href="#">BRC</a>	NB, PRG		F		S	S

<a href="#">UFI</a>	PRG		F		S	S
<a href="#">RFI</a>	PRG			SF	S	S

Использование дополнительных параметров для остальных Норм приведено в следующих таблицах:

## NTD ACI

Type	Flex	TN	TP	TW	CR
<a href="#">BRC</a>	NB, PRG	F		S	S
<a href="#">UFI</a>	PRG	F		S	S
<a href="#">RFI</a>	PRG		F	S	S

## NB(1992)

Type	Flex	R2	RP	RX	TC	TN
<a href="#">WLT</a>	PRG			F	F	
<a href="#">BRC</a>	NB, PRG	S	S			SF

## NB(2010)

Type	Flex	R2	RP	RX	TC	TN
<a href="#">WLT</a>	PRG			F	F	
<a href="#">BRC</a>	NB, PRG	S	S			SF
<a href="#">FWB</a>	PRG		S			SF

## NC(1992)

Type	Flex	R2	RP	RX	TC	TN	TP
<a href="#">WLT</a>	PRG			F	F		
<a href="#">BRC</a>	NB, PRG	S	S			SF	
<a href="#">UFI</a>	PRG					F	
<a href="#">RFI</a>	PRG						SF

## NC(2010)

Type	Flex	R2	RP	RX	TC	TN	TP
<a href="#">WLT</a>	PRG			F	F		
<a href="#">BRC</a>	NB, PRG	S	S			SF	
<a href="#">UFI</a>	PRG	S	S			SF	
<a href="#">RFI</a>	PRG						SF
<a href="#">FWB</a>	PRG		S			SF	

## EN(2002)

Type	Flex	R2	RP	RX	TC	TN	TP
<a href="#">WLT</a>	PRG			F	F		
<a href="#">EXT</a>	PRG						
<a href="#">BRC</a>	NB, PRG	S	S			F	
<a href="#">UFI</a>	PRG					F	
<a href="#">RFI</a>	PRG						SF

## EN(2020)

Type	Flex	R2	RP	RX	TC	TN	TP	CR	CB
<a href="#">WLT</a>	PRG			SF	SF			S	S

<a href="#">EXT</a>	PRG							S	S
<a href="#">BRC</a>	NB, PRG	S	S			F		S	S
<a href="#">UFI</a>	PRG					F		S	S
<a href="#">RFI</a>	PRG						SF	S	S

## B31.1 (2012)

Type	Flex	R2	RP	RX	TC	TN	TP
<a href="#">WLT</a>	PRG			SF	SF		
<a href="#">EXT</a>	PRG						
<a href="#">BRC</a>	NB, PRG	S	S			F	
<a href="#">UFI</a>	PRG					F	
<a href="#">RFI</a>	PRG						SF
<a href="#">WOL</a>	PRG						
<a href="#">SOL</a>	PRG			SF	S		

## 30 Sample of analysis

As an example, the main steam line of the WWER-440 unit has been selected extending from the steam generator header to the containment penetration within the containment area.

### Piping Data

Figure 1 shows the isometric diagram of this piping system and its main dimensions. The piping system is manufactured from steel of grade St 20, working temperature of the content: 271° C, ambient temperature 20° C, internal pressure: 4.5 MPa.

In the hot state, the steam generator headers have the following thermal displacements:

Table 1. Temperature displacements of the steam generator header in the working state.

Nozzle No.	Temperature displacements		
	X	Y	Z
P1	68	54	6
P2	63	57	6
P3	56	60	6
P4	49	64	6
P5	44	67	6

Locations of spring hangers are shown in the figure. The length of hangers rods are given in the table below:

Table 2. Rod Length and number of springs for spring hangers

Support No.	Number of springs	Rod Length, mm
N1	2	2050
N2	1	1010
N3	2	2050
N4	1	830
N5	1	700
N6	1	670

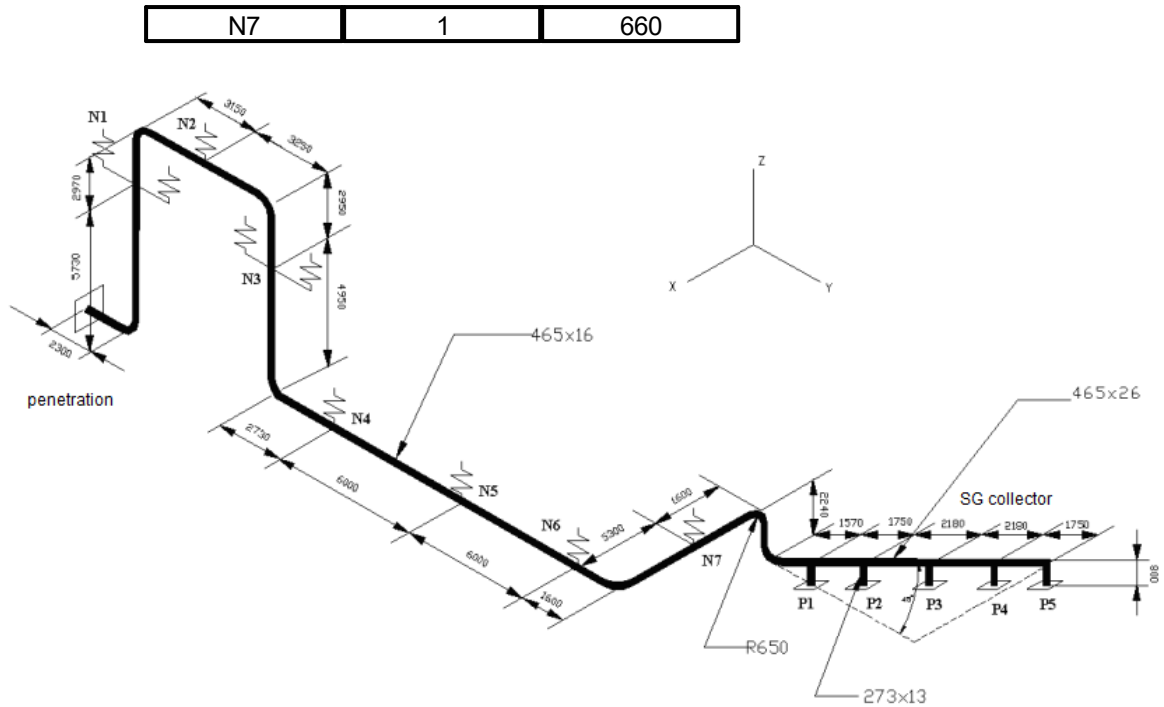

Figure 1. Isometric diagram of the sample piping system

Table 3. Cross-section characteristics (according to OST 24/125.30-89)

DN	Dn, mm	s, mm	c, mm	w, N/mm	R, mm	Smin, mm	a, %
450	465	16	0.8	1.88 (value from OST)	650	12.5	7
450	465	26	1.3	to be determined by the program	-	-	-
250	273	13	0.65	to be determined by the program	-	-	-

## Seismic Load

Seismic load is specified in the form of two groups of floor response spectrums: group SG - for attachment of the piping to the steam generator and group RB - for all the rest of steam line supports (penetration from the reactor compartment and hangers). The response spectrum values are given in Table 4. For supports attributed to group SG, the seismic displacements are specified: X - 33mm, Y - 34mm, Z - 2mm. For group RB, the seismic displacements are taken to be equal to zero. The OBE earthquake is taken equal to a half of SSE.



Table 4. Floor response spectrums of seismic load for the SSE level

	X-Direction		Y-Direction		Z-Direction	
	Frequency, Hz	Acceleration, g	Frequency, Hz	Acceleration, g	Frequency, Hz	Acceleration, g
group SG	0.20	0.06	0.20	0.06	0.20	0.06
	2.00	1.00	2.56	1.37	2.50	0.88
	3.08	1.30	4.17	1.38	4.00	1.11
	4.60	2.50	6.22	2.57	8.00	1.10
	6.54	2.50	8.27	2.58	10.00	1.10
	11.67	1.00	11.67	1.21	12.00	1.13
	17.00	1.00	14.36	1.21	13.00	1.21
	27.00	0.68	28.72	0.61	28.00	0.46
	40.00	0.69	39.68	0.61	40.00	0.47
group RB	0.20	0.06	0.20	0.06	0.20	0.06
	2.00	1.40	2.00	1.40	2.50	0.92
	4.00	2.74	3.00	3.70	7.20	1.65
	4.20	4.00	5.40	3.70	10.50	2.25
	7.00	4.00	6.90	3.20	14.50	2.10
	12.00	1.60	9.00	3.20	17.80	1.80
	16.00	1.60	16.00	1.50	20.00	1.50
	23.00	1.00	23.00	1.00	28.00	0.78
	40.00	1.00	40.00	1.00	40.00	0.78

## Input Data and Run of analysis

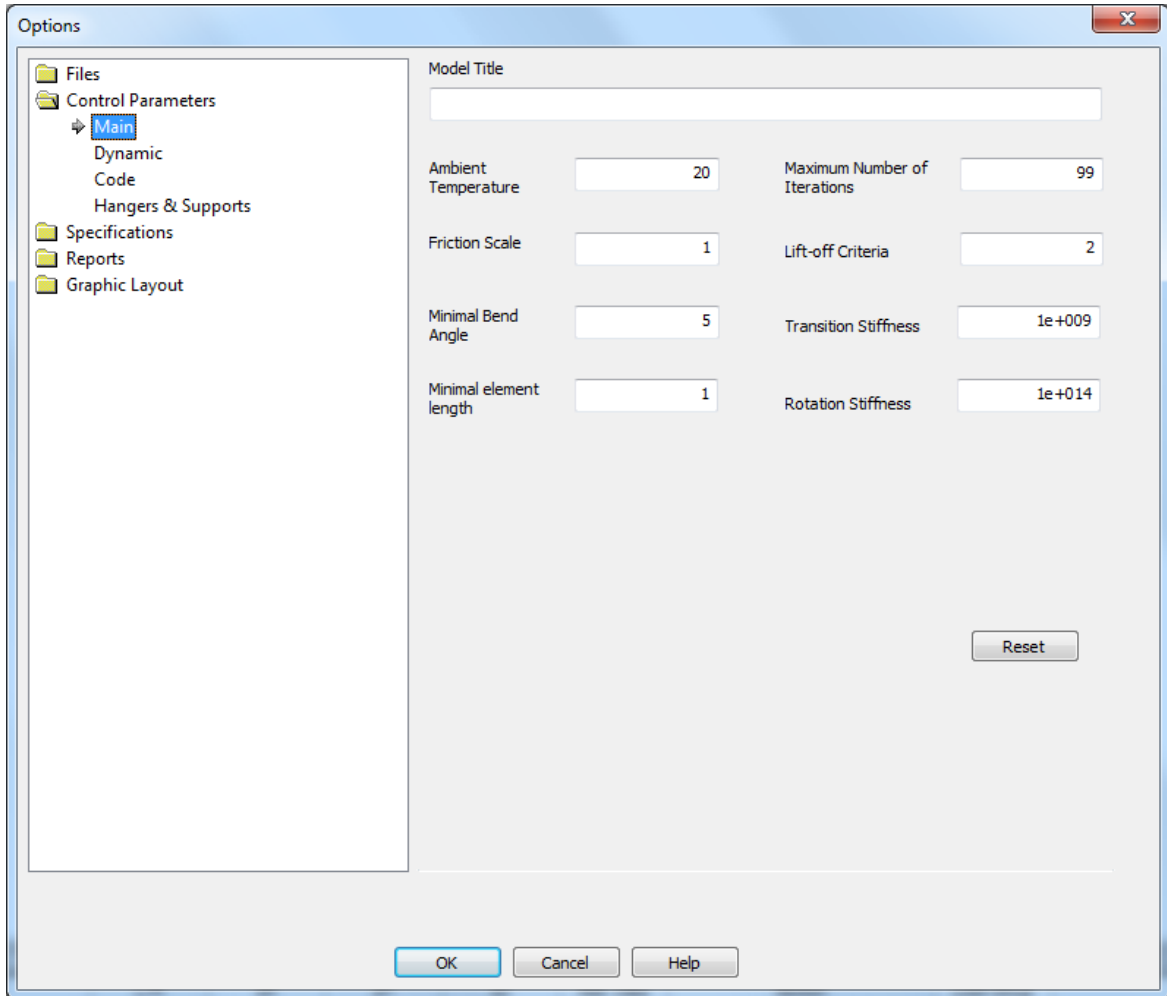
1. Create a working directory on the hard disk (for example, E:\PROJECTS\DPIPE\_WORK\SAMPLE). Run the [DDE](#) program and save a "blank" model in the working directory with a suitable name (for example, "RA\_SAMPLE.DP5").
2. Give a name to the analysis model, which will be displayed in printouts in the form of title ("Service\Options\Reference parameters" menu):



- Determine the type of material for the piping system and specify its physical and mechanical properties (select from the database , or type manually). "Main data\Materials" menu or  button:

Materials. Code: PNAE

	Name	Fatigue	Density	Mu	M	N
✓	1 ST20	CS	7.859	0.3	0	0

	T	E
2	20	200000
3	50	197000
4	100	195000
5	150	192000
6	200	190000
7	250	185000
8	300	180000
9	350	175000
10		

	T	A
2	20	1.15E-005
3	50	1.15E-005
4	100	1.19E-005
5	150	1.22E-005
6	200	1.25E-005
7	250	1.28E-005
8	300	1.31E-005
9	350	1.34E-005
10		

	T	Su	Sy
2	20	402	216
3	50	392	206
4	100	392	206
5	150	392	206
6	200	373	196
7	250	373	196
8	300	363	177
9	350	353	157
10			

4. Determine the piping system cross-sections and the nomenclature of bends being used. "Main data\Pipe cross-sections" menu or  button:

Pipe Sections. Code: PNAE

	Name	Diameter	Wall Thickness	Weight of pipe	C	Material	FW1	FW2	Fi
✓ 1	465x16	465	16	1.73942	0.8	ST20	1	1	
2	465x26	465	26	2.7636	1.3	ST20	1	1	

Std. bend	Name	Radius	Out-of-round.	Smin	Section
1	R650	650	7	12.5	465x16
2					

5. Specify the operating modes of the piping system ("Main data\Operating mode" menu or  button):

Operational Modes

	Name	P	T	CSG
✓ 1	NOL			
				

	Name	P	T	CSG
1	LG1	4.5	271	0
2				

6. Specify the geometry of the piping system, location, types and characteristics of supports:

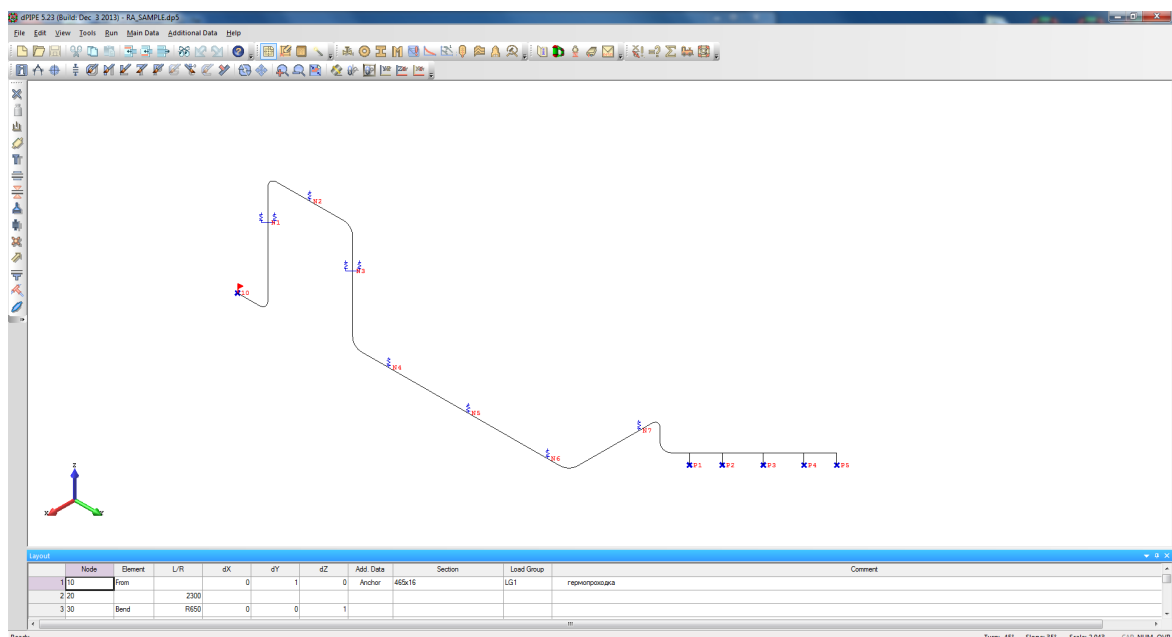

**In the course of input of the geometry, it is recommended to periodically save the input data file on the hard disk!!!.**

7. Specify the temperature displacements of connecting equipment (anchors simulating the connection to SG). "Main data\Additional data\Anchors" menu):

Anchors												
	Node	STX/STA	STY/STH	STZ/STN	SRX/SRA	SRY/SRH	SRZ/SRN	Release	C.System	F <sup>*</sup>	Theta <sup>*</sup>	Element
1	10	1E+009	1E+009	1E+009	1E+014	1E+014	1E+014	No	Global			Pipe (10->20)
2	P1	1E+009	1E+009	1E+009	1E+014	1E+014	1E+014	No	Global			Pipe (T1->P1)
3	P2	1E+009	1E+009	1E+009	1E+014	1E+014	1E+014	No	Global			Pipe (T2->P2)
4	P3	1E+009	1E+009	1E+009	1E+014	1E+014	1E+014	No	Global			Pipe (T3->P3)
5	P4	1E+009	1E+009	1E+009	1E+014	1E+014	1E+014	No	Global			Pipe (T4->P4)



Movements								
	Op. Mode	dX	dY	dZ	Rx	Ry	Rz	
1	NOL	68	54	6	0	0	0	
2								

8. Determined the specification for analysis and post-processing of the results for selecting springs of spring hangers/supports ("Service\Options\Tasks" menu or  button):

Расчет с определением рабочих нагрузок и выбором пружин (#1). Code: PNAE.									
Name	Type	Mode	Load	Pend.	Fric.	NLS	Hng. Stf.	PE	
LC1	DSGN	\$OPER	W	No	No	Yes	No	No	Определение рабочих нагрузок на пруж
LC2	OPER_A	\$OPER	W+P+T+D	No	No	Yes	No	No	Расчет на полную нагрузку
LC3	OPER_B	\$COLD	W+P+T+D	No	No	Yes	Yes	No	Выбор пружин
LC4	OPER_B	\$OPER	W+P+T+D	Yes	Yes	Yes	Yes	No	Этап II (полная нагрузка)
LC5	SUST_C	\$OPER	W+P	No	No	Ref.	No	No	Этап I
LC6	OPER_B	\$COLD	W+P+T+D	Yes	Yes	Yes	Yes	No	Этап IV (холодная нагрузка)

Name	Type	Rule	Print	Load Set	Comment
LS1	S2_NUE	SUM	Yes	LC5	Напряжения S2 (НУЭ)
LS2	SRK	SUM	Yes	LC4-LC6	Напряжения Srk
LS3	SAF	SUM	Yes	LC4-LC6	Напряжения Saf
LS4	DISP	SUM	Yes	LC5	Весовые перемещения
LS5	DISP	SUM	Yes	LC4-LC6	Видимые перемещения
LS6	SUPP	SUM	Yes	LC4	Нагрузки в раб. состоянии
LS7	SUPP	SUM	Yes	LC6	Нагрузки в хол. состоянии
LS8	FORC	SUM	No	LC4-LC5	Температура для ОТТ

9. Execute the analysis ("Batch mode",  button) and view the results of analysis (PIPE3DV,  button):

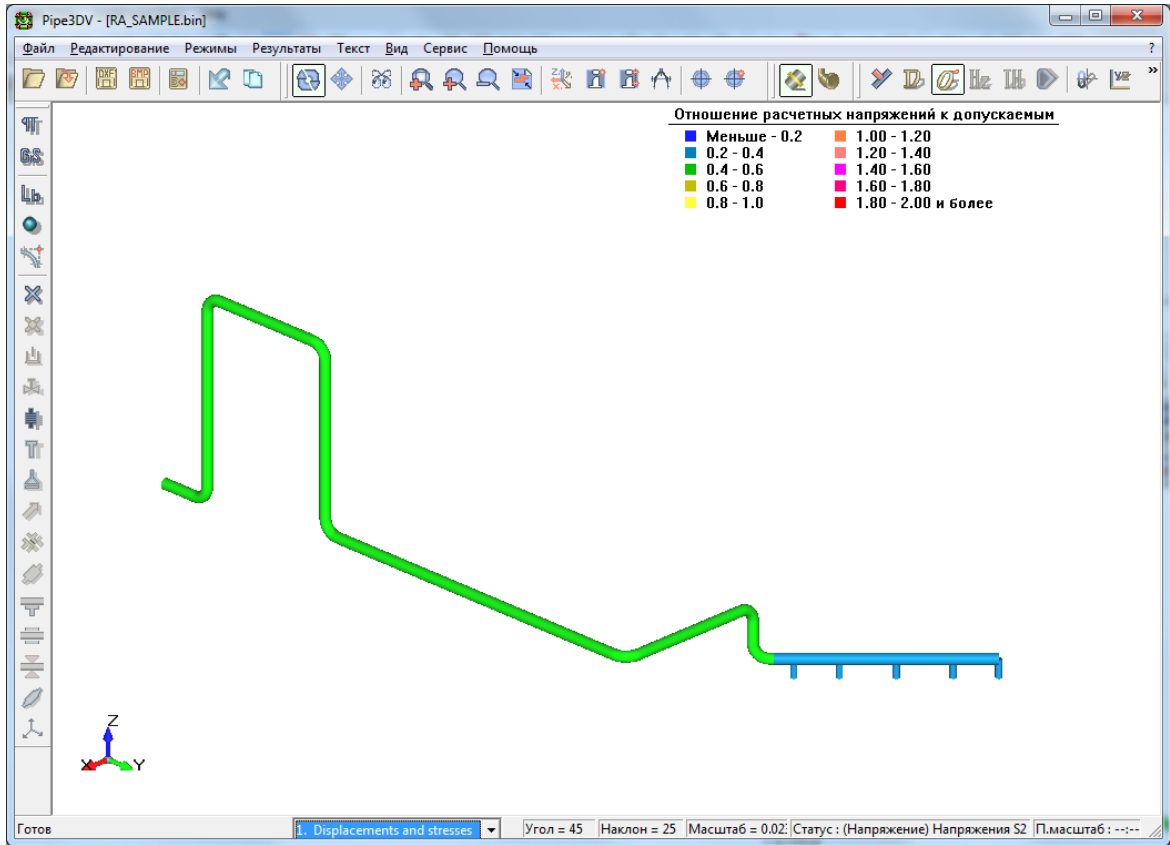

View the results on the selection of springs of spring hangers/supports ("Loads on supports",  button) :

```
>>> Characteristics of spring supports and hangers(for
installation0). Standard OST 108.764.01-80
```

```
=====
Support   NC Chain      Spring height      Total load on
support   visible displacements ALPHA
(node)No. struct.  H_fr. H_work. H_cold. H_1s  P_work.
P_cold    P_seism.  DX    DY    DZ
=====
N1        2   1*19      414   338   319   318   21.40
26.77          4    -1    19    0.1
-----
N2        1   1*06+     201   165   157   154    8.31
10.37          15     6    26    0.9
          1*18     369   298   280   275
-----
N3        2   1*06      201   160   148   133   19.21
24.61          26     8    12    0.8
-----
N4        1   1*06      201   154   160   145   10.88
9.56          40     5    -6    2.8
=====
```

N5	1	1*07	226	181	183	169	12.69
12.10		67	24	-2	5.9		
N6	1	1*07	226	178	173	162	13.55
14.86		91	44	5	8.6		
N7	1	1*20	399	328	314	311	13.38
16.01		78	51	14	8.1		

Note:

- NC - number of chains
- H\_fr. - spring height in the free state, mm
- H\_work. - spring height in the working state, mm
- H\_cold - spring height in the cold state, mm
- H\_1s - spring height with single-stage preload, mm
- P\_work. - load on support in the working state, kN
- P\_cold - load on support in the cold state (without working fluid), kN
- P\_seism. - seismic load on the support, kN
- DX, DY, DZ - visible movements between the cold and working states, mm
- ALPHA - angle of deviation of the hanger tie rod from the vertical, degrees

>>> Summarized table of loads on spring supports and hangers (all stages of analysis)

Support (node)No.	Spring DZ ALPHA	P_des. Analysis	P_work.	FS	var	DX	DY
N1	07/Z2	21.45	21.40	1.8	0	2	-7
20	0.2 LS06		26.77	1.5	25	-1	-6
1	0.2 LS07						
N2	06/Z3	8.35	8.31	2.0	0	12	-5
34	0.7 LS06		10.37	1.6	24	-3	-10
8	0.6 LS07						
N3	06/Z1	19.33	19.21	1.7	1	24	3
27	0.7 LS06		24.61	1.3	27	-2	-6
15	0.2 LS07						

```

-----
-----
N4      06/Z1      10.85  10.88  1.5    0      40     5
      10  2.8  LS06
              9.56  1.7    12     1     0
      15  0.1  LS07
-----
-----
N5      07/Z1      12.65  12.69  1.5    0      67     24
      12  5.8  LS06
              12.10  1.6    4     -1     0
      14  0.1  LS07
-----
-----
N6      07/Z1      13.74  13.55  1.5    1      89     44
      16  8.5  LS06
              14.86  1.3    8     -2     0
      11  0.2  LS07
-----
-----
N7      08/Z2      13.46  13.38  2.0    1      76     52
      16  8.0  LS06
              16.01  1.6   19     -2     0
      2   0.2  LS07
-----

```

## Note:

P\_des.           - design load, kN  
P\_work.          - load for the design mode, kN  
FS               - load safety margin  
var              - variability, %  
DX, DY, DZ      - movements for the design state  
ALPHA           - angle of deviation of the hanger tie rod from  
the vertical, degrees

LS06             - Loads in the working state  
LS07             - Loads in the cold state

>>> Summarized table of loads on anchors and supports

```

-----
-----
Support Cross-section  FX      FY      FZ      MX
MY      MZ  Analysis  ----- (forces, kN) -----
(node)No.)  calculation
(moments, kN*m)
-----
-----
10      465x16      1.2     -6.1     -1.9     34.2
2.7     -18.4  LS06
              -0.1     0.7     7.1     29.5     -
3.2     1.4   LS07
-----
-----
P1      273x13     -29.9    28.3     6.5     -10.1     -
15.0    12.1  LS06
-----

```

1.9	-0.2	LS07	2.2	-2.4	3.6	2.3	-
-----							
P2	273x13		-57.6	14.5	-11.8	-4.1	-
25.4	16.0	LS06					
1.5	-0.2	LS07	-0.8	0.7	-14.3	1.1	-
-----							
P3	273x13		-22.5	54.9	-19.9	-23.1	-
9.4	17.3	LS06					
0.9	-0.1	LS07	-0.3	0.4	-7.1	0.6	-
-----							
P4	273x13		56.8	-49.2	-30.5	19.9	
24.2	13.9	LS06					
0.6	0.0	LS07	-0.4	0.4	-7.0	0.3	-
-----							
P5	273x13		46.6	-44.6	21.8	18.5	
20.5	12.0	LS06					
0.5	0.0	LS07	-0.4	0.5	-3.1	0.2	-

Note:

LS06 - Loads in the working state  
 LS07 - Loads in the cold state

>>> Node: 10  
 Type of support: anchor

Forces:

global:			Fx	Fy	Fz	Mx
My	Mz					
(newton*meter)						
-----						
1	Loads in the working state		1223	-6142	-1883	
34228	2718	-18362				
2	Loads in the cold state		-109	742	7069	
29454	-3166	1430				

Movements:

```

global:
Rx      Ry      Rz      Dx      Dy      Dz
                                (millimeters)
                                (degrees)

```

```

-----
1 Loads in the working state    0      0      0
0.00    0.00    0.00
2 Loads in the cold state       0      0      0
0.00    0.00    0.00
-----

```

```

>>> Node:          P1
      Type of support: anchor

```

Forces:

```

-----
global:
Mx      My      Mz      Fx      Fy      Fz
                                (newtons)
                                (newton*meter)

```

```

-----
1 Loads in the working state  -29938  28299  6541  -
10140  -15000  12149
2 Loads in the cold state     2243   -2406  3621
2332   -1887   -248
-----

```

Movements:

```

-----
global:
Rx      Ry      Rz      Dx      Dy      Dz
                                (millimeters)
                                (degrees)

```

```

-----
1 Loads in the working state    0      0      0
0.00    0.00    0.00
2 Loads in the cold state       0      0      0
0.00    0.00    0.00
-----

```

```

>>> Node:          P2
      Type of support: anchor

```

Forces:

```

-----
global:
Mx      My      Mz      Fx      Fy      Fz
                    (newtons)
      (newton*meter)
-----
1 Loads in the working state  -57570    14466   -11823   -
4060   -25412    15968
2 Loads in the cold state      -818      697   -14303
1059   -1525     -155
-----

```

Movements:

```

-----
global:
      Ry      Rz      Dx      Dy      Dz      Rx
                    (millimeters)
      (degrees)
-----
1 Loads in the working state   0         0         0
0.00      0.00      0.00
2 Loads in the cold state      0         0         0
0.00      0.00      0.00
-----

```

```

>>> Node:          P3
      Type of support:  anchor

```

Forces:

```

-----
global:
Mx      My      Mz      Fx      Fy      Fz
                    (newtons)
      (newton*meter)
-----
1 Loads in the working state  -22503    54858   -19866   -
23122   -9359    17336
2 Loads in the cold state      -344      370   -7121
563     -863     -77
-----

```

Movements:

```

-----
global:
      Ry      Rz      Dx      Dy      Dz      Rx

```

```

                                (millimeters)
      (degrees)
-----
      1 Loads in the working state  0      0      0
0.00      0.00      0.00
      2 Loads in the cold state    0      0      0
0.00      0.00      0.00
-----

```

```

>>> Node:          P4
      Type of support:  anchor

```

Forces:

```

-----
global:          Fx      Fy      Fz
      Mx      My      Mz
                                (newtons)
      (newton*meter)
-----
      1 Loads in the working state  56786  -49216  -30531
19880      24216      13851
      2 Loads in the cold state    -384      354  -6994
302      -577      -37
-----

```

Movements:

```

-----
global:          Dx      Dy      Dz      Rx
      Ry      Rz
                                (millimeters)
      (degrees)
-----
      1 Loads in the working state  0      0      0
0.00      0.00      0.00
      2 Loads in the cold state    0      0      0
0.00      0.00      0.00
-----

```

```

>>> Node:          P5
      Type of support:  anchor

```

Forces:

```

-----
-----

```

```

global:
  Mx      My      Mz      Fx      Fy      Fz
                (newtons)
                (newton*meter)
-----
1 Loads in the working state  46572  -44596  21832
18513  20494  11974
2 Loads in the cold state    -423    497  -3143
171    -462   -24
-----

```

Movements:

```

global:
  Ry      Rz      Dx      Dy      Dz      Rx
                (millimeters)
                (degrees)
-----
1 Loads in the working state  0      0      0
0.00    0.00    0.00
2 Loads in the cold state    0      0      0
0.00    0.00    0.00
-----

```

```

>>> Node:          N1
      Type of support:  spring hanger, number of chains:
NC = 2

```

```

      Spring:          07/Z2 (OST80). Chain structure:
1*19 (Maximum working travel - 140 mm)

```

```

      Design load:          21451      H_fr. = 226/414
mm
      Theoretical installation load:  26973      H_1s = 178/318
mm
-----

```

```

                P      Pmax      Pmin      FS
H_70  H_140  Var                (newtons)
(millimeters)  %
-----
1 Loads in the working state  21404  39325                1.84
188    338    0
2 Loads in the cold state    26774  39325                1.47
178    319    25
-----

```

Movements:

```

-----
-----
                                Dx      Dy      Dz
ALPHA
                                (millimeters)
degrees
-----
-----
1 Loads in the working state  -1.34   -5.92   0.71   0.2
-----
-----

```

```

>>> Node:          N2
      Type of support:  spring hanger, number of chains:
NC = 1

```

```

      Spring:          06/Z3 (OST80). Chain structure:
1*06+1*18 (Maximum working travel - 210 mm)

```

```

      Design load:          8349      H_fr. = 201/369
mm
      Theoretical installation load: 10980      H_1s = 154/275
mm

```

```

-----
-----
                                P      Pmax      Pmin      FS
H_70  H_140  Var
                                (newtons)
(millimeters)  %
-----
-----
1 Loads in the working state  8312   16338           1.97
165   298   0
2 Loads in the cold state    10371  16338           1.58
157   280   24
-----
-----

```

Movements:

```

-----
-----
                                Dx      Dy      Dz      ALPHA
                                (millimeters)
degrees
-----
-----
1 Loads in the working state  11.54   -4.87   34.28   0.7
2 Loads in the cold state    -3.18   -10.43   7.82   0.6
-----
-----

```

```

>>> Node:          N3

```

Type of support: spring hanger, number of chains:  
 NC = 2

Spring: 06/Z1 (OST80). Chain structure:  
 1\*06 (Maximum working travel - 70 mm)

Design load: 19326 H\_fr. = 201 mm  
 Theoretical installation load: 31667 H\_1e = 133 mm

H_70	H_140	Var	P	Pmax	Pmin	FS
(millimeters)		%	(newtons)			
1	160	1	19206	32676		1.70
2	148	27	24611	32676		1.33

Movements:

ALPHA	Dx	Dy	Dz	
degrees	(millimeters)			
1	24.07	2.61	26.69	0.7
2	-2.25	-5.59	15.12	0.2

>>> Node: N4  
 Type of support: spring hanger, number of chains:  
 NC = 1

Spring: 06/Z1 (OST80). Chain structure:  
 1\*06 (Maximum working travel - 70 mm)

Design load: 10845 H\_fr. = 201 mm  
 Theoretical installation load: 13155 H\_1e = 145 mm

H_70	H_140	Var	P	Pmax	Pmin	FS
(millimeters)		%	(newtons)			

1	Loads in the working state	10879	16338	1.50
154	0			
2	Loads in the cold state	9560	16338	1.71
160	12			

Movements:

	Dx	Dy	Dz		
ALPHA					
				(millimeters)	
				degrees	
1	Loads in the working state	40.47	4.68	9.75	2.8
2	Loads in the cold state	0.72	-0.15	15.40	0.1

>>> Node: N5  
 Type of support: spring hanger, number of chains:  
 NC = 1

Spring: 07/Z1 (OST80). Chain structure:  
 1\*07 (Maximum working travel - 70 mm)

Design load:	12651	H_fr. = 226 mm
Theoretical installation load:	15974	H_1θ = 169 mm

H_70	H_140	Var	P	Pmax	Pmin	FS
						(newtons)
						(millimeters) %
1	Loads in the working state		12691	19662		1.55
181	0					
2	Loads in the cold state		12095	19662		1.63
183	4					

Movements:

	Dx	Dy	Dz
ALPHA			
			(millimeters)
			degrees

```

1 Loads in the working state      66.76   24.14   11.69
5.8
2 Loads in the cold state         -0.73   -0.15   13.81
0.1
-----
-----

```

```

>>> Node:                N6
      Type of support:    spring hanger, number of chains:
NC = 1

```

```

      Spring:            07/Z1 (OST80). Chain structure:
1*07 (Maximum working travel - 70 mm)

```

```

      Design load:                13738   H_fr. = 226 mm
      Theoretical installation load: 17992   H_1s = 162 mm
-----
-----

```

```

                                     P      Pmax      Pmin      FS
H_70  H_140  Var
(millimeters)  %
-----
-----

```

```

1 Loads in the working state 13553   19662           1.45
178      1
2 Loads in the cold state    14862   19662           1.32
173      8
-----
-----

```

Movements:

```

                                     Dx      Dy      Dz
ALPHA
(millimeters)
degrees
-----
-----

```

```

1 Loads in the working state  89.31   43.59   15.80   8.5
2 Loads in the cold state    -1.76   -0.15   11.14   0.2
-----
-----

```

```

>>> Node:                N7
      Type of support:    spring hanger, number of
chains: NC = 1

```

```

      Spring:            08/Z2 (OST80). Chain structure:
1*20 (Maximum working travel - 140 mm)

```

Design load: 13456 H\_fr. = 221/399  
 mm  
 Theoretical installation load: 16468 H\_1s = 177/311  
 mm

H_70	H_140	Var	P	Pmax	Pmin	FS
(millimeters)		%	(newtons)			
185	328	1	13376	26341		1.97
178	314	19	16007	26341		1.65

Movements:

ALPHA	Dx	Dy	Dz	
degrees	(millimeters)			
1	76.33	51.62	16.43	8.0
2	-1.89	0.21	2.45	0.2

10. In order to execute the seismic stability analysis it is necessary to enter the floor response spectrums for various support groups ("Main data\Response spectrums" menu,  button):

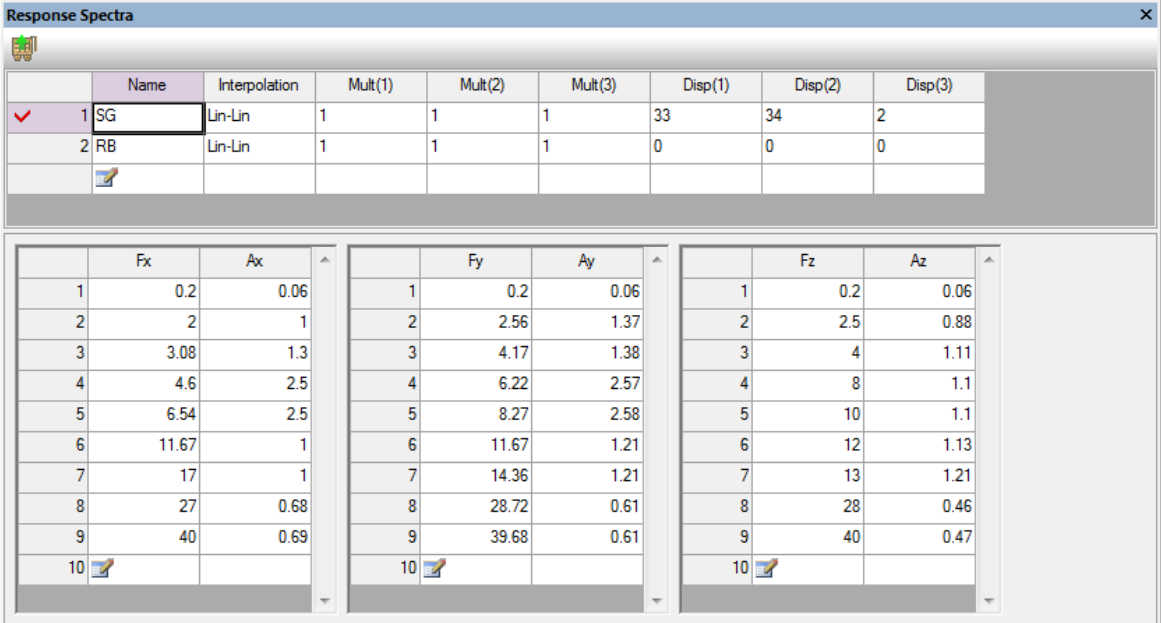

**Response Spectra**

Name	Interpolation	Mult(1)	Mult(2)	Mult(3)	Disp(1)	Disp(2)	Disp(3)
1 SG	Lin-Lin	1	1	1	33	34	2
2 RB	Lin-Lin	1	1	1	0	0	0

Fx	Ax
1	0.2
2	2
3	3.08
4	4.6
5	6.54
6	11.67
7	17
8	27
9	40
10	

Fy	Ay
1	0.2
2	2.56
3	4.17
4	6.22
5	8.27
6	11.67
7	14.36
8	28.72
9	39.68
10	

Fz	Az
1	0.2
2	2.5
3	4
4	8
5	10
6	12
7	13
8	28
9	40
10	

If the spectrums are located in separate files, then it is possible to load them by pressing the (  ) button.

- For all supports of the model, it is necessary to determine the corresponding seismic group ("Additional data\Anchors" and "Additional data\Spring hangers" menus):

Anchors													
	Node	STX/STA	STY/STH	STZ/STN	SRX/SRA	SRV/SRH	SRZ/SRN	Release	C.System	F <sup>o</sup>	Theta <sup>a</sup>	Element	Seismic Group
1	I0	1E+009	1E+009	1E+009	1E+014	1E+014	1E+014	No	Global			Pipe (I0->20)	RB
2	P1	1E+009	1E+009	1E+009	1E+014	1E+014	1E+014	No	Global			Pipe (T1->P1)	SG
3	P2	1E+009	1E+009	1E+009	1E+014	1E+014	1E+014	No	Global			Pipe (T2->P2)	SG
4	P3	1E+009	1E+009	1E+009	1E+014	1E+014	1E+014	No	Global			Pipe (T3->P3)	SG
5	P4	1E+009	1E+009	1E+009	1E+014	1E+014	1E+014	No	Global			Pipe (T4->P4)	SG
6	P5	1E+009	1E+009	1E+009	1E+014	1E+014	1E+014	No	Global			Pipe (T5->P5)	SG

Movements							
	Op. Mode	dX	dY	dZ	Rx	Ry	Rz
1	NOL	68	54	6	0	0	0
2							

The same operation can be executed via the spreadsheet interface by using the "Service\ Determine seismic support groups" menu item (  )

- It is possible to check the correctness of the assignment of seismic groups for a certain support by pressing the  button on the toolbar.

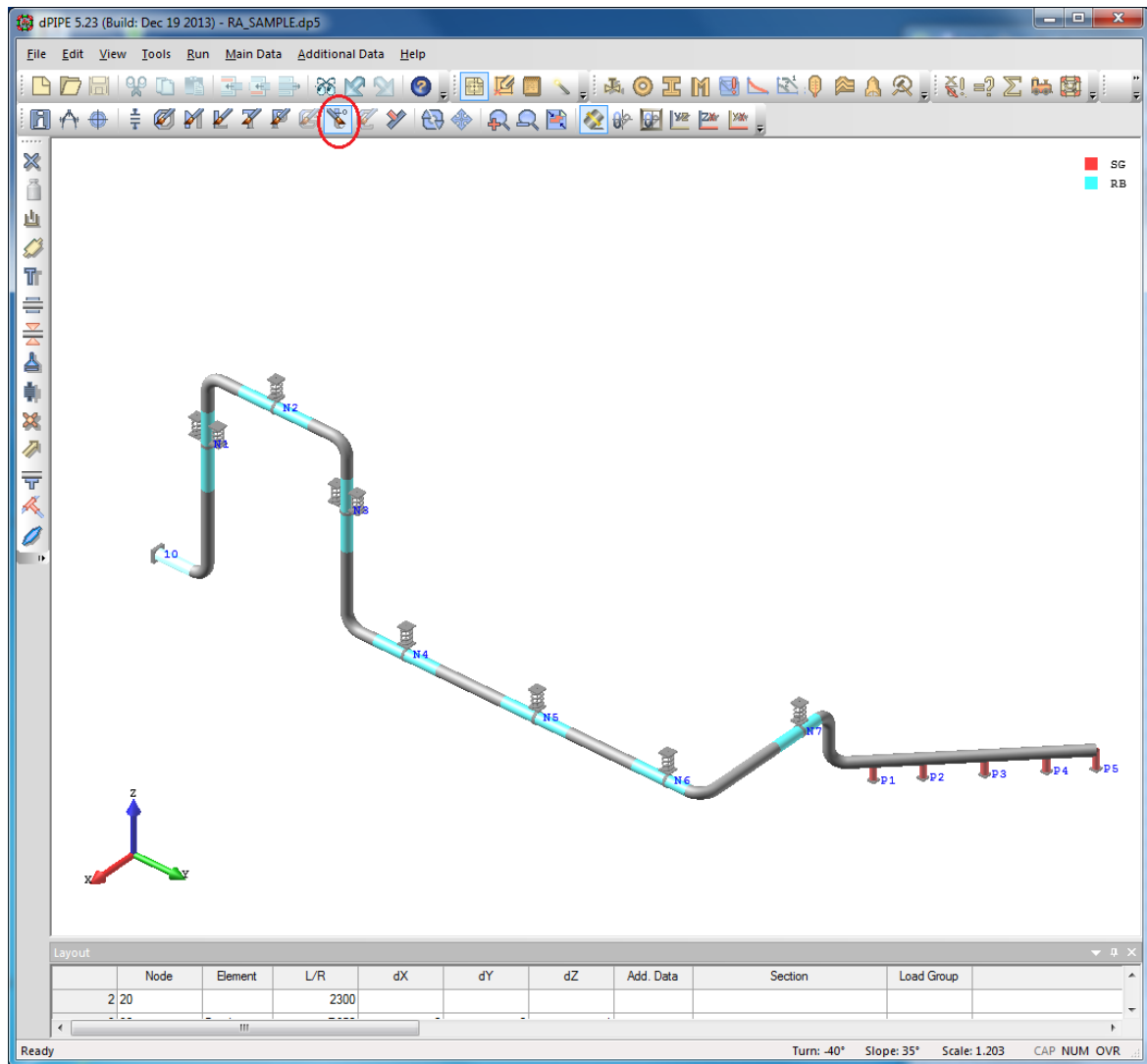

13. Specify the method of analysis for dynamic analysis ([DYN](#)) as the response spectrum method (RSM), limit frequency [FMAX](#) as 33 Hz and the parameter for automatic breakdown of the model [FMESH](#) as 60 Hz ("Service\Options\Reference parameters\Dynamic" menu):

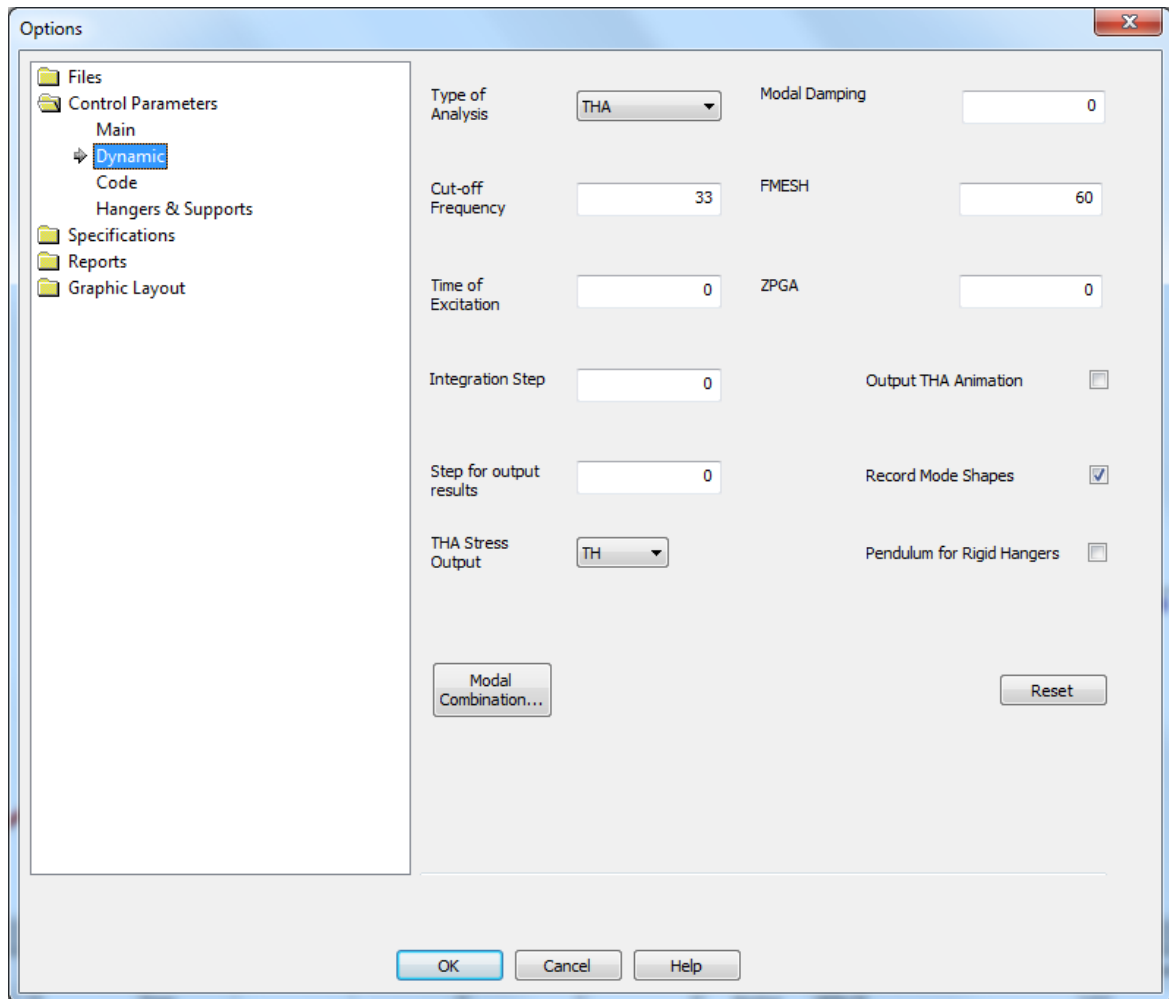

14. In the "Modal combination..." dialog, place check-marks in the "Allowance for higher forms of vibration" and "Allowance for seismic displacement of supports" items:

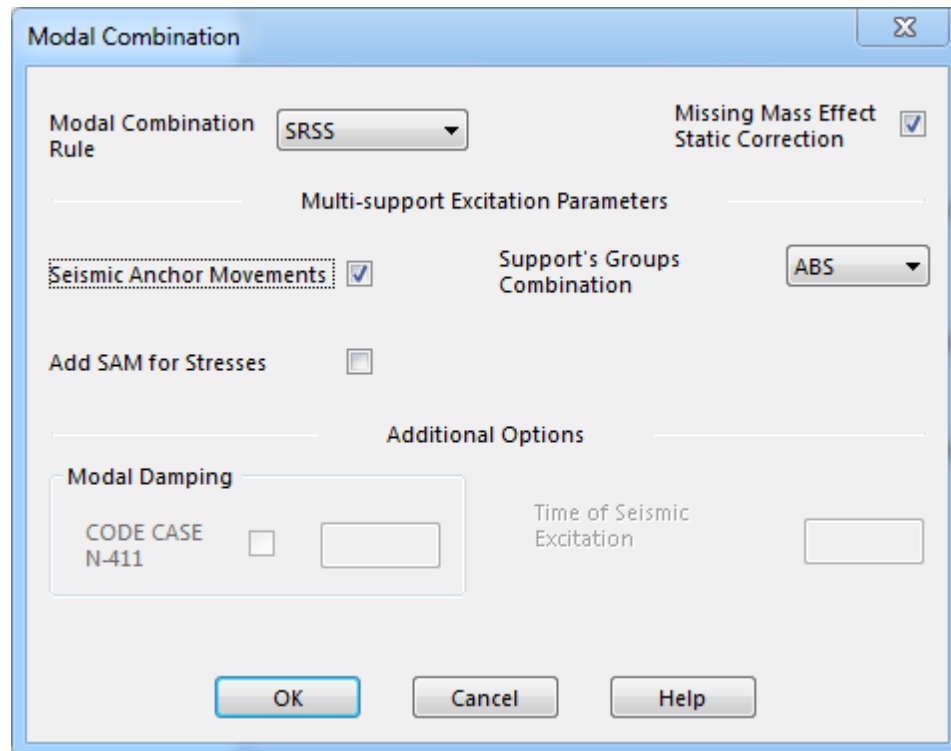

15. Load the specification for analysis including seismic factors ("Service\Options\Tasks" menu or  button):

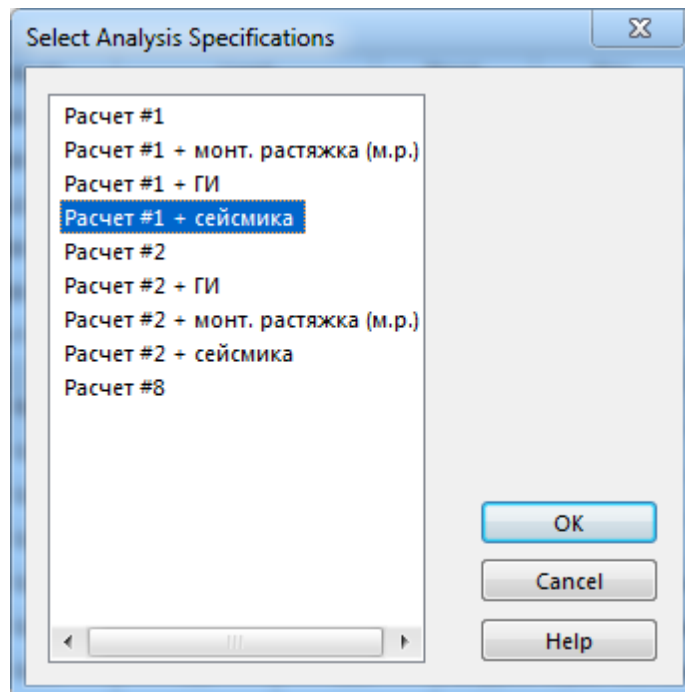

16. In order to execute the analysis and view the results, it is necessary to repeat the operations set forth in Item 9